

ΔΗΛΩΣΗ ΕΠΙΔΟΣΕΩΝ

DoP 0255

για fischer FIF - CN II (Πλαστικό αγκύριο για χρήση σε σκυρόδεμα και τούβλο)

EL

1. <u>Μοναδικός κωδικός ταυτοποίησης του τύπου του προϊόντος:</u>	DoP 0255		
2. <u>Προβλεπόμενη(-ες) χρήση(-εις):</u>	Καρφωτό πλαστικό αγκύριο για στήριξη συστημάτων θερμοπρόσοψης σε σκυρόδεμα και τούβλο με σοβά, δείτε το παράρτημα, ειδικά τα παραρτήματα B1- B3.		
3. <u>Κατασκευαστής:</u>	fischerwerke GmbH & Co. KG, Klaus-Fischer-Str. 1, 72178 Waldachtal, Γερμανία		
4. <u>Εξουσιοδοτημένος αντιπρόσωπος:</u>	-		
5. <u>Σύστημα/συστήματα AVCP (αξιολόγηση και επαλήθευση της σταθερότητας της επίδοσης):</u>	2+		
6. <u>Ευρωπαϊκό έγγραφο αξιολόγησης:</u> Ευρωπαϊκή τεχνική αξιολόγηση: Οργανισμός τεχνικής αξιολόγησης: Κοινοποιημένος(-οι) οργανισμός(-οι):	EAD 330196-01-0604 ETA-18/0393; 2018-05-29 DIBt- Deutsches Institut für Bautechnik 2873 TU Darmstadt		
7. <u>Δηλωθείσα(-ες) επίδοση(-εις):</u> Ασφάλεια στη χρήση (BWR 4) Χαρακτηριστική αντοχή:	Χαρακτηριστική εφελκυστική αντοχή: Ελάχιστη απόσταση από ακμή: Ελάχιστη απόσταση αγκυρίων:	Παράρτημα C1 Παράρτημα B2 Παράρτημα B2	
Μετατόπιση:	Φορτίο εφελκυσμού με συντελεστή ασφαλείας: Μετατόπιση:	Παράρτημα C1 Παράρτημα C1	
Ακαμψία δίσκου:	Διάμετρος δίσκου: Αντοχή δίσκου σε φορτίο: Ακαμψία δίσκου:	Παράρτημα C1 Παράρτημα C1 Παράρτημα C1	
Εξοικονόμηση ενέργειας και συγκράτηση θερμότητας (BWR 6) Θερμική αγωγιμότητα:	Σημειακή θερμική αγωγιμότητα αγκυρίου: Πάχος θερμοπρόσοψης:	Παράρτημα C1 Παράρτημα C1	
8. <u>Κατάλληλη τεχνική τεκμηρίωση και/ή ειδική τεχνική τεκμηρίωση:</u>	-		

Η επίδοση του προϊόντος που ταυτοποιείται ανωτέρω είναι σύμφωνη με τη (τις) δηλωθείσα(-ες) επίδοση(-εις). Αυτή η δήλωση επιδόσεων εκδίδεται σύμφωνα με τον Κανονισμό (ΕΕ) Αρ. 305/2011 με αποκλειστική ευθύνη του κατασκευαστή που προσδιορίζεται παραπάνω.

Υπογραφή για λογαριασμό και εξ ονόματος του κατασκευαστή από:

Dr. Oliver Geibig, Γενικός Διευθυντής Επιχειρηματικών Μονάδων & Μηχανικής
Tumlingen, 2021-01-15

Jürgen Grün, Γενικός Διευθυντής Χημικών & Ποιότητας

Αυτή η Δήλωση Επιδόσεων μεταφράστηκε σε διάφορες γλώσσες. Σε περίπτωση που υπάρχει αμφιβολία για τη μετάφραση, υπερισχύει πάντα η αγγλική έκδοση.

Το παράρτημα περιλαμβάνει προαιρετικές και συμπληρωματικές πληροφορίες στα αγγλικά, που ξεπερνούν τις (οριζόμενες σε άλλες γλώσσες) νόμιμες απαιτήσεις.

Specific Part

1 Technical description of the product

The Fischer FIF-CN II consists of an anchor sleeve with an enlarged shaft made of polypropylene (virgin material), an insulation plate made of glass fibre reinforced polyamide (virgin material) and a specific compound nail (for FIF-CN II 60-180) made of glass fibre reinforced polyamide with galvanized steel or a specific nail (for FIF-CN II 200-340) made of galvanized steel which is installed together with a plastic cylinder made of glass fibre reinforced polyamide.

The anchor may in addition be combined with the slip-on-plate DT 90, DT 110 and DT 140.

The product description is given in Annex A.

2 Specification of the intended use in accordance with the applicable European Assessment Document

The performances given in Section 3 are only valid if the anchor is used in compliance with the specifications and conditions given in Annex B.

The verification and assessment methods on which this European Technical Assessment is based lead to the assumption of a working life of the anchor of at least 25 years. The indications given on the working life cannot be interpreted as a guarantee given by the producer, but are to be regarded only as a means for choosing the right products in relation to the expected economically reasonable working life of the works.

3 Performance of the product and references to the methods used for its assessment

3.1 Safety and accessibility in use (BWR 4)

Essential characteristic	Performance
Characteristic tension resistance	See Annex C 1
Edge distances and spacing	See Annex B 2
Plate stiffness	See Annex C 1
Displacements	See Annex C 1

3.2 Energy economy and heat retention (BWR 6)

Essential characteristic	Performance
Point thermal transmittance	See Annex C 1

4 Assessment and verification of constancy of performance (AVCP) system applied, with reference to its legal base

In accordance with EAD No. 330196-01-0604, the applicable European legal act is: [97/463/EC].

The system to be applied is: 2+

Installed anchor: FIF-CN II / 60-180

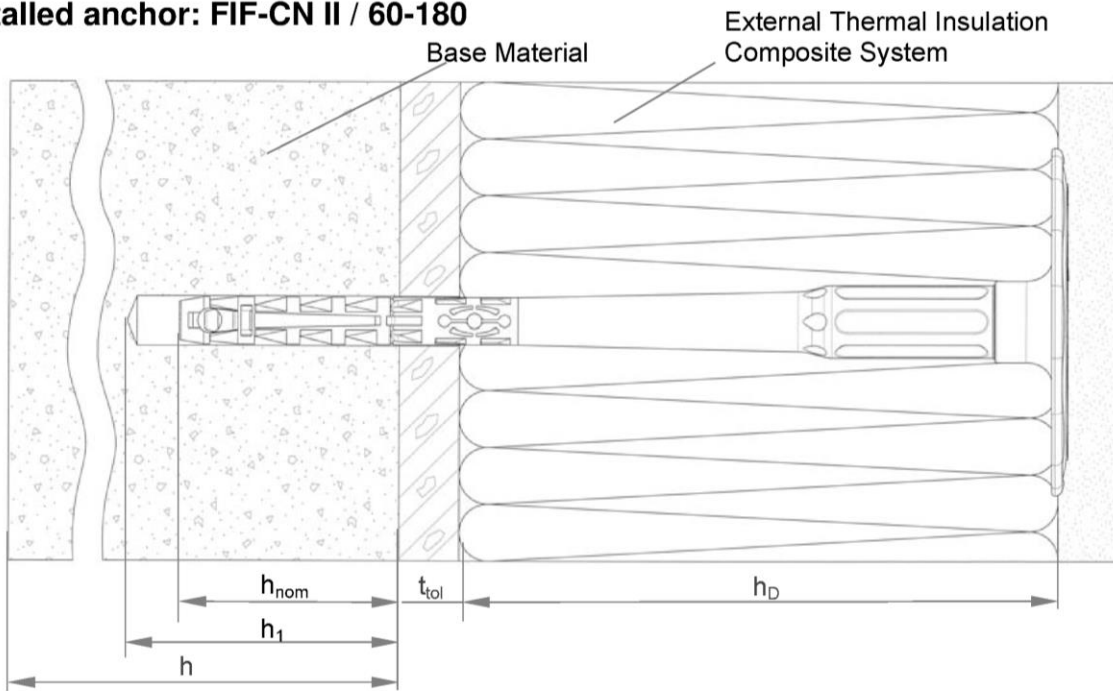

FIF-CN II / 200-340

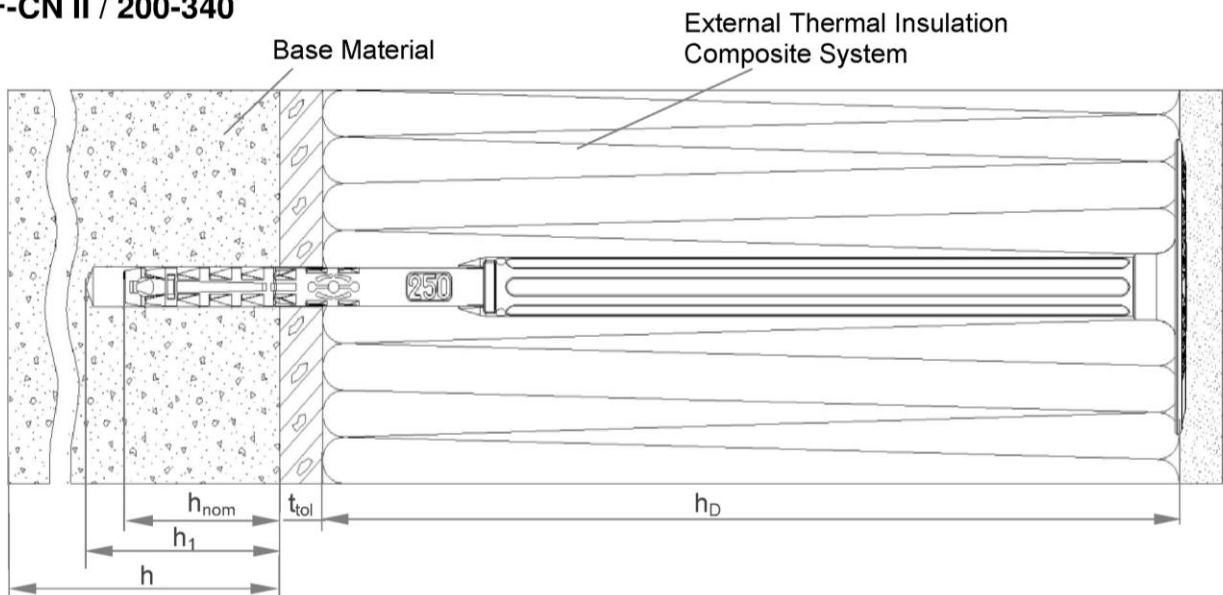

Legend

- h_{nom} = Overall plastic anchor embedment depth in the base material
- h_1 = Depth of drilled hole to deepest point
- h = Thickness of member (wall)
- h_D = Thickness of insulation material
- t_{tol} = Thickness of equalizing layer or non-load bearing coating

Figures not to scale

fischer FIF-CN II

Product description
Installed anchor

Annex A 1

Appendix 2 / 8

Single parts: FIF-CN II / 60-180

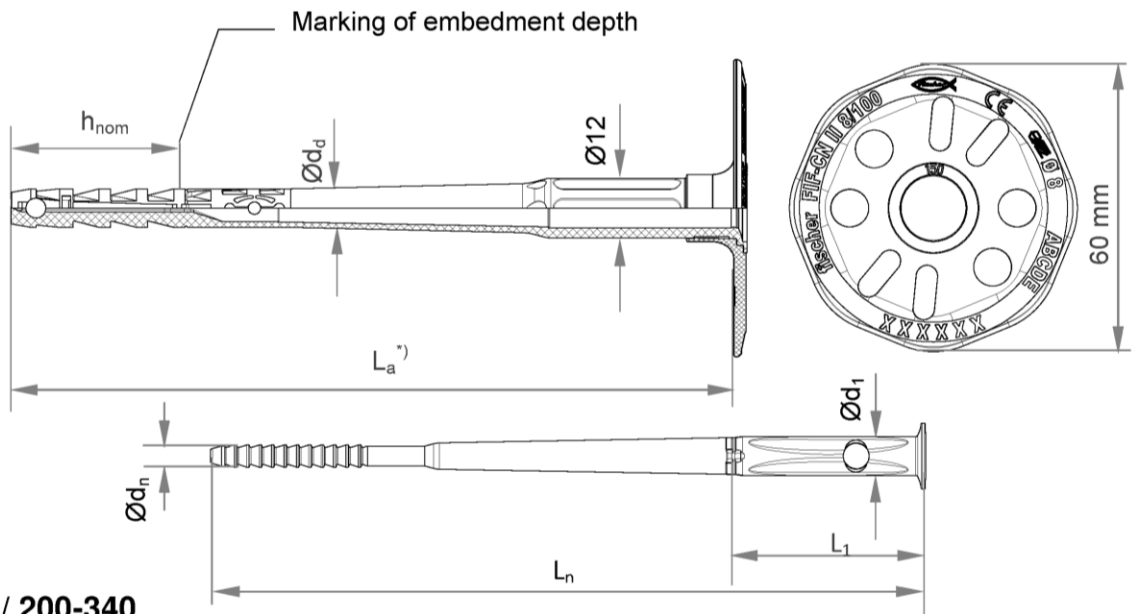

FIF-CN II / 200-340

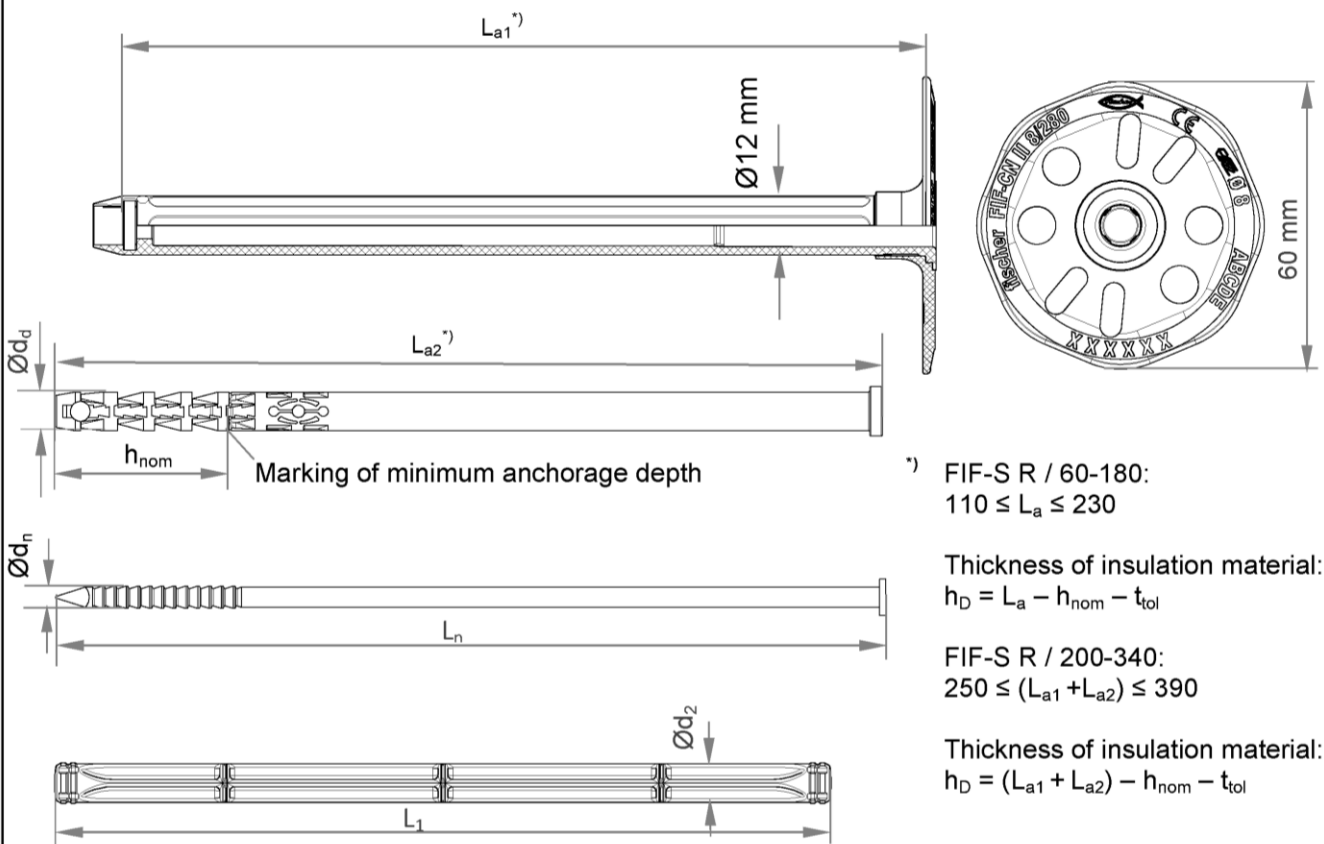

*) FIF-S R / 60-180:
 $110 \leq L_a \leq 230$

Thickness of insulation material:
 $h_D = L_a - h_{nom} - t_{tol}$

FIF-S R / 200-340:
 $250 \leq (L_{a1} + L_{a2}) \leq 390$

Thickness of insulation material:
 $h_D = (L_{a1} + L_{a2}) - h_{nom} - t_{tol}$

Figures not to scale

fischer FIF-CN II

Product description
 Marking and dimensions of the anchor

Annex A 2

Appendix 3 / 8

Table A3.1: Marking



Anchor type	FIF-CN II
Name and size of anchor	FIF-CN II 8
Thickness of insulation material	60, 80, 100, 120, ... 340
Example	fischer FIF-CN II 8/100  or  or blank CE (optional) Ø 8  (optional) ABCDE

Table A3.2: Dimensions

Anchor type	Anchor sleeve				Specific nail			Plastic cylinder	
	Ø d _d	h _{nom}	L _{a,min}	L _{a,max}	Ø d _n	L _n	Ø d ₁	L ₁	Ø d ₂
	[mm]								
FIF-CN II 60-180	8	35	110	230	4,5	L _a - 4	8	40	-
FIF-CN II 200-340	8	35	250	390	4,5	(L _{a1} + L _{a2}) - L ₁ - 4		157	8

Table A3.3: Materials

Designation	Material
Anchor sleeve	PP (virgin material), colour: grey
Shaft (FIF-CN II / 200-340)	PA6 (virgin material) GF, colour: grey
Plastic cylinder (FIF-CN II / 60 – 180)	PA6 (virgin material) GF, colour: nature
Specific compound nail (FIF-CN II / 60-180) o Specific nail (FIF-CN II / 200-340)	PA6 (virgin material) GF, steel gal Zn A2G or A2F acc.to EN ISO 4042:2001-01 Steel gal Zn A2G or A2F acc. to EN ISO 4042:2001-01
Anchor plate	PA6 (virgin material) GF, colour: grey

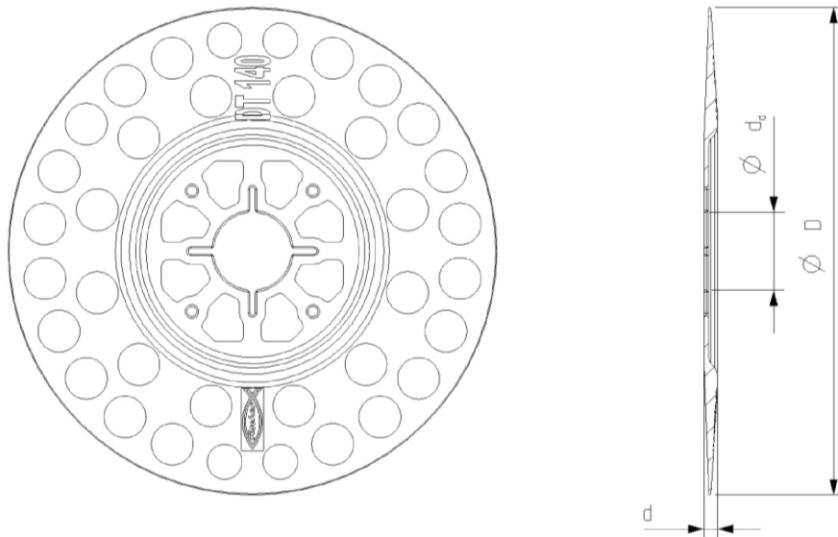
Slip-on-plate combined with FIF-CN II**Table A3.4: Slip-on-plate, diameters and material**

Slip-on-plate	Ø D	Ø d _d	d	Material
		[mm]		
DT 90 / 110 / 140	90 / 110 / 140	22,5	3,9	PA6 GF

Figures not to scale

fischer FIF-CN II

Product description

Marking, dimensions, materials, slip-on plates combined with FIF-CN II

Annex A 3

Appendix 4 / 8

Specifications of intended use

Anchorage subject to:

- The anchor may only be used for transmission of wind suction loads and shall not be used for the transmission of dead loads of the thermal insulation composite system.

Base materials:

- Normal weight concrete (use category A), according to Annex C1.
- Solid masonry (use category B), according to Annex C1.
- Hollow or perforated masonry (use category C), according to Annex C1.
- Lightweight aggregate concrete (use category D), according to Annex C1.
- Autoclaved aerated concrete (use category E), according to Annex C1.
- For other base materials of the use categories A, B, C, D and E the characteristic resistance of the anchor may be determined by job site tests acc. to EOTA Technical Report TR 051 Edition December 2016.

Temperature Range:

- 0 °C to + 40 °C (max. short term temperature +40°C and max. long term temperature +24°C).

Design:

- The anchorages are designed under the responsibility of an engineer experienced in anchorages and masonry work with the partial safety factors $\gamma_M = 2,0$ and $\gamma_F = 1,5$, if there are no other national regulations.
- Verifiable calculation notes and drawings are prepared taking account of the loads to be anchored. The position of the anchors is indicated on the design drawings.
- Fasteners are only to be used for multiple fixings of the ETICS.

Installation:

- Hole drilling by the drill modes according to Annex C1.
- Anchor installation carried out by appropriately qualified personnel and under the supervision of the person responsible for technical matters on the site.
- Installation temperature from 0 °C to + 40 °C
- Exposure to UV due to solar radiation of the anchor not protected by rendering ≤ 6 weeks.

fischer FIF-CN II

Intended use
Specification

Annex B 1

Appendix 5 / 8

Table B2.1: Installation parameters

Anchor type		FIF-CN II
Drill hole diameter	$d_0 =$	8
Cutting diameter of drill bit	$d_{cut} \leq$	8,45
Depth of drill hole to deepest point	$h_1 \geq$	45 / 65 ¹⁾
Overall plastic anchor embedment depth in the base material	$h_{nom} \geq$	35 / 55 ¹⁾

¹⁾ only for use cat. "D" and "E"

Table B2.2: Minimum thickness, distance and spacing

Anchor type		FIF-CN II
Minimum thickness of member	h_{min}	100
Minimum spacing	$s_{min} =$	100
Minimum edge distance	c_{min}	100

Anordnung Achs- und Randabstände

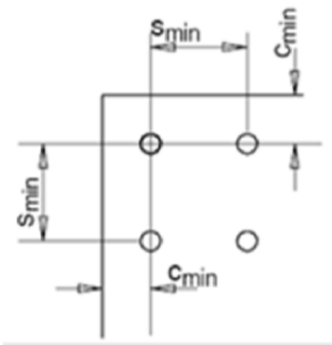

Figures not to scale

fischer FIF-CN II

Intended use
Installation parameters, edge distances and spacings

Annex B 2

Appendix 6 / 8

Installation instructions:

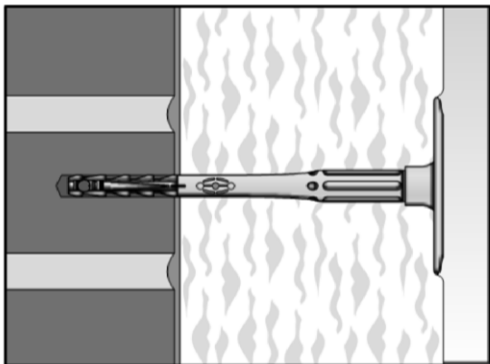
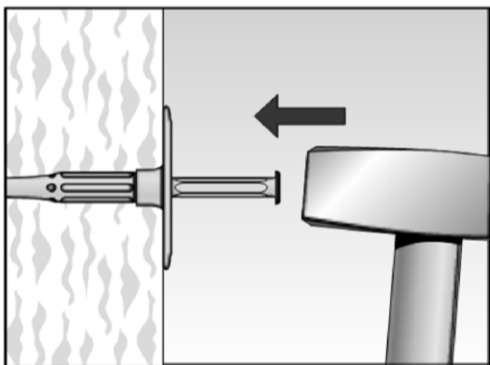
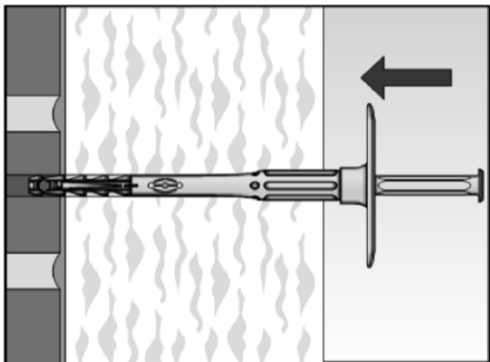
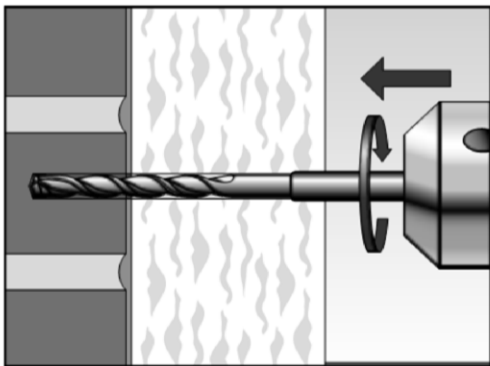

1. Drill the bore hole by the parameters acc. to Table B2.1 and the corresponding drilling method acc. to Annex C 1.

2. Insert anchor manually.

3. Set anchor by hammer blows. The bottom side of the plate must be flush with the ETICS.

4. Correctly installed anchor.

Figures not to scale

fischer FIF-CN II

Intended use
Installation instructions

Annex B 3

Appendix 7 / 8

Table C1.1: Characteristic resistance N_{RK} in concrete and masonry for a single anchor

Base material	Use cat.	Bulk density class ρ [kg/dm ³]	Min. compressive strength f_b [N/mm ²]	Remarks	Drill method ¹⁾	Characteristic resistance FIF-CN II N_{RK} [kN]
Concrete ≥ C12/15 – C50/60 acc.to EN 206-1:2000	A				H	0,75
Clay brick Mz, acc. to EN 771-1:2011	B	≥ 2,0	12	Cross section reduced up to 15% by perforation vertically to the resting area	H	0,75
Vertically perforated clay bricks H1z , acc. to EN 771-1:2011	C	≥ 1,0	12	Cross section between 15 % and 50 % by perforation vertically to the resting area. Outer web thickness ≥ 12 mm	R	0,5
Lightweight aggregate concrete, LAC , acc. to EN 1520:2011	D	≥ 0,8	6	Minimum solid brick or minimum exterior web thickness $t \geq 50$ mm	H	0,5
Autoclaved aerated concrete blocks AAC , acc. to EN 771-4:2011, $h_{nom} = 35$ mm	E	≥ 0,4	4	-	R	0,3

¹⁾ H = Hammer drilling

R = Rotary drilling

Table C1.2: Point thermal transmittance acc. to EOTA Technical Report TR 025: 2016-05

Anchor type	Thickness of insulation material h_D [mm]	Point thermal transmittance χ [W/K]
FIF-CN II / 60-180	60	0,001
	80 - 180	0,000
FIF-CN II / 200-340	200 - 300	0,000
	320 - 340	0,001

Table C1.3: Plate stiffness acc. to EOTA Technical Report TR 026: 2016-05

Anchor plate	Size of the anchor plate [mm]	Load resistance of the anchor plate [kN]	Plate stiffness [kN/mm]
FIF-CN II	60	1,63	0,63

Table C1.4: Displacements of the FIF-CN II

Base material	Tension load F [kN]	Displacements δ [mm]
Concrete C12/15 – C50/60 (EN 206-1:2000)	0,25	< 0,3
Clay brick, Mz 12 (EN 771-1:2011)	0,25	< 0,5
Vertically perforated clay brick, H1z 12 (EN 771-1:2011)	0,17	< 0,2
Lightweight aggregate concrete, LAC 6 (EN 1520:2011)	0,17	< 0,3
Autoclaved aerated concrete blocks, AAC 4 (EN 771-4:2011)	0,10	< 0,2

fischer FIF-CN II

Performances

Characteristic resistance of the anchor

Point thermal transmittance, plate stiffness and displacements

Annex C 1

Appendix 8 / 8