

## ΔΗΛΩΣΗ ΕΠΙΔΟΣΕΩΝ

### DoP 0336

για fischer Anchor Channel InnoLock FES-RS-S με fischer Channel Bolts FBC-S (Κανάλια αγκύρωσης για χρήση σε σκυρόδεμα)

EL

- |  |  |
|--|--|
| 1. <u>Μοναδικός κωδικός ταυτοποίησης του τύπου του προϊόντος:</u>  | <b>DoP 0336</b>  |
| 2. <u>Προβλεπόμενη(-ες) χρήση(-εις):</u>   | <b>Κανάλι αγκύρωσης για χρήση σε ρηγματωμένο ή μη ρηγματωμένο σκυρόδεμα, δείτε το παράρτημα, ειδικά τα Παραρτήματα B1- B6.</b>           |
| 3. <u>Κατασκευαστής:</u>   | <b>fischerwerke GmbH &amp; Co. KG, Klaus-Fischer-Str. 1, 72178 Waldachtal, Γερμανία</b>  |
| 4. <u>Εξουσιοδοτημένος αντιπρόσωπος:</u>   | -  |
| 5. <u>Σύστημα/συστήματα AVCP (αξιολόγηση και επαλήθευση της σταθερότητας της επίδοσης):</u>  | <b>1</b>   |
| 6. <u>Ευρωπαϊκό έγγραφο αξιολόγησης:</u><br>Ευρωπαϊκή τεχνική αξιολόγηση:<br>Οργανισμός τεχνικής αξιολόγησης:<br>Κοινοποιημένος(-οι) οργανισμός(-οι):  | <b>EAD 330008-03-0601, Edition 06/2021<br/>ETA-22/0035; 2022-08-01<br/>DIBt- Deutsches Institut für Bautechnik<br/>2873 TU Darmstadt</b> |
| 7. <u>Δηλωθείσα(-ες) επίδοση(-εις):</u><br><b><u>Μηχανική αντίσταση και σταθερότητα (BWR1)</u></b><br><b>Χαρακτηριστική αντίσταση σε εφελκυστικό φορτίο (στατικό και σχεδόν στατικό):</b><br>1) Αντίσταση σε αστοχία χάλυβα των αγκυριών:: Παράρτημα C1<br>2) Αντοχή στη χαλύβδινη αστοχία της σύνδεσης μεταξύ αγκυριών και καναλιού: Παράρτημα C1<br>3) Αντοχή στη χαλύβδινη αστοχία των χειλέων του καναλιού και, κατά συνέπεια, στην αποκόλληση του κοιλία του καναλιού: Παράρτημα C1<br>4) Αντοχή του κοιλία ράγας σε αστοχία του χάλυβα: Παράρτημα C6<br>5) Αντοχή σε αστοχία του χάλυβα λόγω υπέρβασης της αντοχής του καναλιού σε κάμψη: Παραρτήματα A5, C1<br>6) Μέγιστη ροπή στρέψης εγκατάστασης για την αποφυγή ζημιών κατά την εγκατάσταση: Παράρτημα B4<br>7) Αντίσταση σε αστοχία από εξόγκωση: Παράρτημα C2<br>8) Αντίσταση σε αστοχία από κώνο σκυροδέματος: Παραρτήματα B3, C2<br>9) Ελάχιστη απόσταση ακμών, αποστάσεις, πάχος μέλους για την αποφυγή διάσπασης του σκυροδέματος κατά την εγκατάσταση: Παραρτήματα A5, B3<br>10) Χαρακτηριστική απόσταση και απόσταση ακμών για την αποφυγή διάσπασης του σκυροδέματος υπό φορτίο: Παράρτημα C2<br><br>11) Αντίσταση σε αστοχία από έκρηξη- περιοχή έδρασης της κεφαλής: Παράρτημα A4<br><br><b>Χαρακτηριστική αντίσταση σε διατμητικό φορτίο (στατικό και σχεδόν στατικό):</b><br>12) Αντοχή σε αστοχία χάλυβα του κοιλία καναλιού υπό διατμητική φόρτιση χωρίς μοχλοβραχίονα: Παράρτημα C6<br>13) Αντοχή σε αστοχία χάλυβα από κάμψη του κοιλία καναλιού υπό διατμητική φόρτιση με μοχλοβραχίονα: Παράρτημα C7<br>14) Αντοχή σε χαλύβδινη αστοχία των χειλέων του καναλιού, χαλύβδινη αστοχία της σύνδεσης μεταξύ αγκυρίου και καναλιού ή χαλύβδινη αστοχία του αγκυρίου (διατμητικό φορτίο στην εγκάρσια κατεύθυνση): Παραρτήματα C4<br>15) Αντοχή σε αστοχία χάλυβα της σύνδεσης μεταξύ των χειλέων του καναλιού και του κοιλία του καναλιού (διατμητικό φορτίο στον διαμηκή άξονα του καναλιού): Παράρτημα C5<br>16) Συντελεστής ευαισθησίας στην εγκατάσταση: Παράρτημα C5<br>17) Αντίσταση σε χαλύβδινη αστοχία του αγκυρίου: Παράρτημα C4<br>18) Αντοχή σε χαλύβδινη αστοχία της σύνδεσης μεταξύ αγκυρίου και καναλιού: Παράρτημα C4<br>19) Αντοχή στην αστοχία του σκυροδέματος: Παράρτημα C5<br>20) Αντίσταση σε αστοχία ακμής σκυροδέματος: Παράρτημα C5<br><br><b>Χαρακτηριστική αντοχή υπό συνδυασμένες στατικές και οιονεί στατικές εφελκυστικές και διατμητικές φορτίσεις</b><br>21) Αντοχή σε χαλύβδινη αστοχία του καναλιού αγκύρωσης: Παράρτημα C6<br><br><b>Χαρακτηριστική αντοχή σε φόρτιση εφελκυσμού λόγω κόπωσης:</b><br>22) Αντοχή σε κόπωση σε αστοχία του χάλυβα ολόκληρου του συστήματος (συνεχής ή τριγραμμική συνάρτηση) NPD<br><br>23) Οριακή αντοχή σε κόπωση σε αστοχία του χάλυβα ολόκληρου του συστήματος NPD<br>24) Αντοχή σε κόπωση σε αστοχία που σχετίζεται με το σκυρόδεμα (εκθετική συνάρτηση) NPD<br>25) Αντοχή στο όριο κόπωσης σε αστοχία που σχετίζεται με το σκυρόδεμα NPD<br>26) Μετατόπιση: Παραρτήματα C3, C6<br><br><b><u>Ασφάλεια σε περίπτωση φωτιάς (BWR 2)</u></b><br>27) Αντίδραση σε φωτιά: Κατηγορία (A1)<br>28) Αντίσταση στη φωτιά: NPD<br><br><b><u>Διάρκεια:</u></b><br>29) Διάρκεια: Παραρτήματα A7, B1 |  |



8. Κατάλληλη τεχνική τεκμηρίωση και/ή ειδική τεχνική τεκμηρίωση: --

Η επίδοση του προϊόντος που ταυτοποιείται ανωτέρω είναι σύμφωνη με τη (τις) δηλωθείσα(-ες) επίδοση(-εις). Αυτή η δήλωση επιδόσεων εκδίδεται σύμφωνα με τον Κανονισμό (ΕΕ) Αρ. 305/2011 με αποκλειστική ευθύνη του κατασκευαστή που προσδιορίζεται παραπάνω.

Υπογραφή για λογαριασμό και εξ ονόματος του κατασκευαστή από:

Dr.-Ing. Oliver Geibig, Γενικός Διευθυντής Επιχειρηματικών Μονάδων & Μηχανικής  
Tumlingen, 2023-07-25

Jürgen Grün, Γενικός Διευθυντής Χημικών & Ποιότητας

Αυτή η Δήλωση Επιδόσεων μεταφράστηκε σε διάφορες γλώσσες. Σε περίπτωση που υπάρχει αμφιβολία για τη μετάφραση, υπερισχύει πάντα η αγγλική έκδοση.

Το παράρτημα περιλαμβάνει προαιρετικές και συμπληρωματικές πληροφορίες στα αγγλικά, που ξεπερνούν τις (οριζόμενες σε άλλες γλώσσες) νόμιμες απαιτήσεις.

Translation guidance Essential Characteristics and Performance Parameters for Annexes

**Οδηγίες Μετάφρασης των βασικών χαρακτηριστικών και απόδοσης για τα παραρτήματα**

**Mechanical resistance and stability (BWR 1)**

**Μηχανική αντίσταση και σταθερότητα (BWR1)**

Characteristic resistance to tension load (static and quasi-static loading):

**Χαρακτηριστική αντίσταση σε εφελκυστικό φορτίο (στατικό και σχεδόν στατικό):**

1	Resistance to steel failure of anchors: <b>Αντίσταση σε αστοχία χάλυβα των αγκυριών::</b>	$N_{Rk,s,a}$
2	Resistance to steel failure of the connection between anchors and channel: <b>Αντοχή στη χαλύβδινη αστοχία της σύνδεσης μεταξύ αγκυριών και καναλιού:</b>	$N_{Rk,s,c}$
3	Resistance to steel failure of channel lips and subsequently pullout of channel bolt: <b>Αντοχή στη χαλύβδινη αστοχία των χειλέων του καναλιού και, κατά συνέπεια, στην αποκόλληση του κοχλία του καναλιού:</b>	$N_{Rk,s,l}^0 ; S_{I,N}$
4	Resistance to steel failure of channel bolt: <b>Αντοχή του κοχλία ράγας σε αστοχία του χάλυβα:</b>	$N_{Rk,s}$
5	Resistance to steel failure by exceeding the bending strength of the channel: <b>Αντοχή σε αστοχία του χάλυβα λόγω υπέρβασης της αντοχής του καναλιού σε κάμψη:</b>	$M_{Rk,s,flex} ; S_{max}$
6	Maximum installation torque moment to avoid damage during installation: <b>Μέγιστη ροπή στρέψης εγκατάστασης για την αποφυγή ζημιών κατά την εγκατάσταση:</b>	$T_{inst,g} ; (T_{inst,s})$
7	Resistance to pull-out failure of the anchor: <b>Αντίσταση σε αστοχία από εξόλκευση:</b>	$N_{Rk,p}$
8	Resistance to concrete cone failure: <b>Αντίσταση σε αστοχία από κώνο σκυροδέματος:</b>	$k_{cr,N} ; k_{ucr,N} ; \eta_{ef}$
9	Minimum edge distance, spacing, member thickness to prevent concrete splitting during installation: <b>Ελάχιστη απόσταση ακμών, αποστάσεις, πάχος μέλους για την αποφυγή διάσπασης του σκυροδέματος κατά την εγκατάσταση:</b>	$S_{min}, C_{min}, \eta_{min}$
10	Characteristic edge distance and spacing to avoid splitting of concrete under load: <b>Χαρακτηριστική απόσταση και απόσταση ακμών για την αποφυγή διάσπασης του σκυροδέματος υπό φορτίο:</b>	$S_{cr,sp} ; C_{cr,sp}$
11	Resistance to blowout failure- bearing area of head: <b>Αντίσταση σε αστοχία από έκρηξη- περιοχή έδρασης της κεφαλής:</b>	$A_h$

Characteristic resistance to shear load (static and quasi-static loading):

**Χαρακτηριστική αντίσταση σε διατμητικό φορτίο (στατικό και σχεδόν στατικό):**

12	Resistance to steel failure of channel bolt under shear loading without lever arm: <b>Αντοχή σε αστοχία χάλυβα του κοχλία καναλιού υπό διατμητική φόρτιση χωρίς μοχλοβραχίονα:</b>	$V_{Rk,s}$
13	Resistance to steel failure by bending of the channel bolt under shear load with lever arm: <b>Αντοχή σε αστοχία χάλυβα από κάμψη του κοχλία καναλιού υπό διατμητική φόρτιση με μοχλοβραχίονα:</b>	$M_{Rk,s}^0$
14	Resistance to steel failure of channel lips, steel failure of connection between anchor and channel or steel failure of anchor (shear load in transverse direction): <b>Αντοχή σε χαλύβδινη αστοχία των χειλέων του καναλιού, χαλύβδινη αστοχία της σύνδεσης μεταξύ αγκυριού και καναλιού ή χαλύβδινη αστοχία του αγκυριού (διατμητικό φορτίο στην εγκάρσια κατεύθυνση):</b>	$V_{Rk,s,l,y}^0 ; S_{I,V} ; V_{Rk,s,c,y} ; V_{Rk,s,a,y}$
15	Resistance to steel failure of connection between channel lips and channel bolt (shear load in longitudinal channel axis): <b>Αντοχή σε αστοχία χάλυβα της σύνδεσης μεταξύ των χειλέων του καναλιού και του κοχλία του καναλιού (διατμητικό φορτίο στον διαμήκη άξονα του καναλιού):</b>	$V_{Rk,s,l,x}$
16	Factor for sensitivity to installation: <b>Συντελεστής ευαισθησίας στην εγκατάσταση:</b>	$\gamma_{inst}$
17	Resistance to steel failure of the anchor: <b>Αντίσταση σε χαλύβδινη αστοχία του αγκυριού:</b>	$V_{Rk,s,a,x}$
18	Resistance to steel failure of connection between anchor and channel: <b>Αντοχή σε χαλύβδινη αστοχία της σύνδεσης μεταξύ αγκυριού και καναλιού:</b>	$V_{Rk,s,c,x}$
19	Resistance to concrete pry-out failure: <b>Αντοχή στην αστοχία του σκυροδέματος:</b>	$k_g$
20	Resistance to concrete edge failure: <b>Αντίσταση σε αστοχία ακμής σκυροδέματος:</b>	$k_{cr,V} ; k_{ucr,V}$

Characteristic resistance under combined static and quasi-static tension and shear loading

**Χαρακτηριστική αντοχή υπό συνδυασμένες στατικές και οιονεί στατικές εφελκυστικές και διατμητικές φορτίσεις**

21	Resistance to steel failure of the anchor channel: <b>Αντοχή σε χαλύβδινη αστοχία του καναλιού αγκύρωσης:</b>	$k_{13}, k_{14}$
----	--	------------------

Characteristic resistance under fatigue tension loading:

**Χαρακτηριστική αντοχή σε φόρτιση εφελκυσμού λόγω κόπωσης:**

22	Fatigue resistance to steel failure of the whole system (continuous or tri-linear function): <b>Αντοχή σε κόπωση σε αστοχία του χάλυβα ολόκληρου του συστήματος (συνεχής ή τριγραμμική συνάρτηση)</b>	$\Delta N_{Rk,s,0,n}$ ( $n=1$ to $n=\infty$ )
23	Fatigue limit resistance to steel failure of the whole system: <b>Οριακή αντοχή σε κόπωση σε αστοχία του χάλυβα ολόκληρου του συστήματος</b>	$\Delta N_{Rk,s,0,\infty}$
24	Fatigue resistance to concrete related failure (exponential function): <b>Αντοχή σε κόπωση σε αστοχία που σχετίζεται με το σκυρόδεμα (εκθετική συνάρτηση)</b>	$\Delta N_{Rk,c,0,n} ; \Delta N_{Rk,p,0,n}$ ( $n=1$ to $n=\infty$ )
25	Fatigue limit resistance to concrete related failure: <b>Αντοχή στο όριο κόπωσης σε αστοχία που σχετίζεται με το σκυρόδεμα</b>	$\Delta N_{Rk,c,0,\infty} ; \Delta N_{Rk,p,0,\infty}$
26	Displacements: <b>Μετατόπιση:</b>	$\delta_{N0} ; \delta_{N\infty} ; \delta_{V,y,0} ; \delta_{V,y,\infty}$ $\delta_{V,x,0} ; \delta_{V,x,\infty}$

Safety in case of fire (BWR 2)

**Ασφάλεια σε περίπτωση φωτιάς (BWR 2)**

27	Reaction to fire: <b>Αντίδραση σε φωτιά:</b>	Class
28	Resistance to fire: <b>Αντίσταση στη φωτιά:</b>	$N_{Rk,s,fi} ; V_{Rk,s,fi}$

Durability:

**Διάρκεια:**

29	Durability: <b>Διάρκεια:</b>	Description
----	---------------------------------	-------------

## Specific Part

### 1 Technical description of the product

The fischer Serrated Anchor Channel InnoLock FES-RS-S with fischer Serrated Channel Bolts FBC-S is a system consisting of a C-shaped channel profile of steel and at least two metal anchors non-detachably fixed on the channel back and fischer Serrated Channel Bolts.

The anchor channel is embedded surface-flush in the concrete. fischer Serrated Channel Bolts with appropriate hexagonal nuts and washers are fixed to the channel.

The product description is given in Annex A.

### 2 Specification of the intended use in accordance with the applicable European Assessment Document

The performances given in Section 3 are only valid if the anchor channel is used in compliance with the specifications and conditions given in Annex B.

The verifications and assessment methods on which this European Technical Assessment is based lead to the assumption of a working life of the anchor channel of at least 50 years. The indications given on the working life cannot be interpreted as a guarantee given by the producer, but are to be regarded only as a means for choosing the right products in relation to the expected economically reasonable working life of the works.

### 3 Performance of the product and references to the methods used for its assessment

#### 3.1 Mechanical resistance and stability (BWR 1)

Essential characteristic	Performance
Characteristic resistance under tension load (static and quasi-static loading)	
- Resistance to steel failure of anchors	$N_{Rk,s,a}$ see Annex C1
- Resistance to steel failure of the connection between anchors and channel	$N_{Rk,s,c}$ see Annex C1
- Resistance to steel failure of channel lips and subsequently pull-out of channel bolt	$N_{Rk,s,l}^0$ ; $S_{l,N}$ see Annex C1
- Resistance to steel failure of channel bolt	$N_{Rk,s}$ see Annex C6
- Resistance to steel failure by exceeding the bending strength of the channel	$S_{max}$ see Annex A5 $M_{Rk,s,flex}$ see Annex C1
- Maximum installation torque to avoid damage during installation	$T_{inst,g}$ ; $T_{inst,s}$ see Annex B4
- Resistance to pull-out failure of the anchor	$N_{Rk,p}$ see Annex C2
- Resistance to concrete cone failure	$h_{ef}$ see Annex B3 $k_{cr,N}$ ; $k_{ucr,N}$ see Annex C2
- Minimum edge distances, spacing and member thickness to avoid concrete splitting during installation	$S_{min}$ see Annex A5 $c_{min}$ ; $h_{min}$ see Annex B3
- Characteristic edge distance and spacing to avoid splitting of concrete under load	$S_{cr,sp}$ ; $c_{cr,sp}$ see Annex C2
- Resistance to blowout failure - bearing area of anchor head	$A_h$ see Annex A4

Essential characteristic	Performance
<p>Characteristic resistance under shear load (static and quasi-static loading)</p> <ul style="list-style-type: none"> <li>- Resistance to steel failure of channel bolt under shear loading without lever arm</li> <li>- Resistance to steel failure by bending of the channel bolt under shear load with lever arm</li> <li>- Resistance to steel failure of channel lips, steel failure of connection between anchor and channel and steel failure of anchor (shear load in transverse direction)</li> <li>- Resistance to steel failure of connection between channel lips and channel bolt (shear load in longitudinal channel axis)</li> <li>- Factor for sensitivity to installation (longitudinal shear)</li> <li>- Resistance to steel failure of the anchor (longitudinal shear)</li> <li>- Resistance to steel failure of connection between anchor and channel (longitudinal shear)</li> <li>- Resistance to concrete pry-out failure</li> <li>- Resistance to concrete edge failure</li> </ul>	<p><math>V_{Rk,s}</math> see Annex C6</p> <p><math>M_{Rk,s}^0</math> see Annex C7</p> <p><math>V_{Rk,s,l,y}^0</math> ; <math>S_{l,v}</math> ; <math>V_{Rk,s,c,y}</math> ; <math>V_{Rk,s,a,y}</math> see Annex C4</p> <p><math>V_{Rk,s,l,x}</math> see Annex C5</p> <p><math>\gamma_{inst}</math> see Annex C5</p> <p><math>V_{Rk,s,a,x}</math> see Annex C4</p> <p><math>V_{Rk,s,c,x}</math> see Annex C4</p> <p><math>k_8</math> see Annex C5</p> <p><math>k_{cr,v}</math> ; <math>k_{ucr,v}</math> see Annex C5</p>
<p>Characteristic resistance under combined tension and shear load (static and quasi-static load)</p> <ul style="list-style-type: none"> <li>- Resistance to steel failure of the anchor channel</li> </ul>	<p><math>k_{13}</math> ; <math>k_{14}</math> see Annex C6</p>
<p>Characteristic resistance under fatigue tension loading</p> <ul style="list-style-type: none"> <li>- Fatigue resistance to steel failure of the whole system (continuous or tri-linear function, test method A1, A2)</li> <li>- Fatigue limit resistance to steel failure of the whole system (test method B)</li> <li>- Fatigue resistance to concrete related failure (exponential function, test method A1, A2)</li> <li>- Fatigue limit resistance to concrete related failure (test method B)</li> </ul>	<p>No Performance assessed</p> <p>No Performance assessed</p> <p>No Performance assessed</p> <p>No Performance assessed</p>
<p>Displacements (static and quasi-static load)</p>	<p><math>\delta_{N0}</math> ; <math>\delta_{N\infty}</math> see Annex C3</p> <p><math>\delta_{v,y,0}</math> ; <math>\delta_{v,y,\infty}</math> ; <math>\delta_{v,x,0}</math> ; <math>\delta_{v,x,\infty}</math> see Annex C6</p>

**3.2 Safety in case of fire (BWR 2)**

<b>Essential characteristic</b>	<b>Performance</b>
Reaction to fire	Class A1
Characteristic resistance to fire	No performance assessed

**3.3 Aspects of durability linked with the Basic Works Requirements**

<b>Essential characteristic</b>	<b>Performance</b>
Durability	See Annex B1

**4 Assessment and verification of constancy of performance (AVCP) system applied, with reference to its legal base**

In accordance with EAD No. 330008-03-0601, the applicable European legal act is: [2000/273/EC].

The system to be applied is: 1

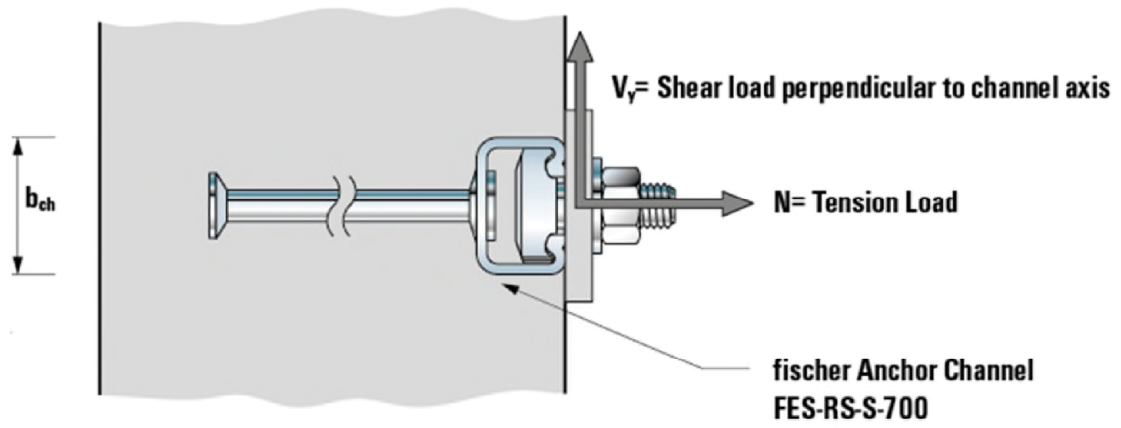
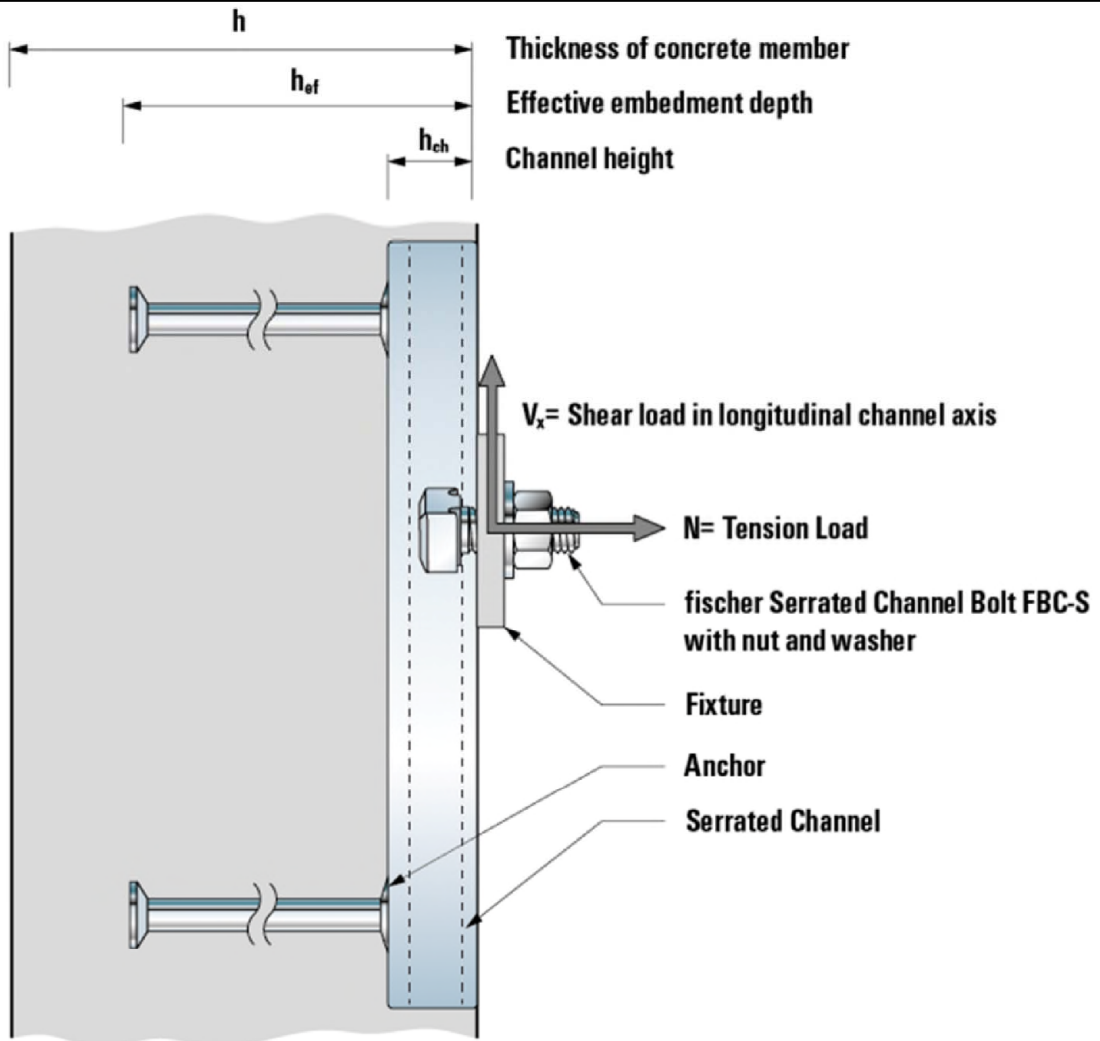

fischer Serrated Anchor Channel InnoLock FES-RS-S with fischer Serrated Channel Bolts FBC-S

**Product Description**  
Installed conditions

Annex A1  
Appendix 4 / 23

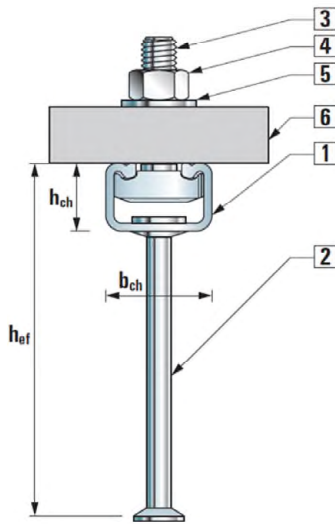

Round anchor

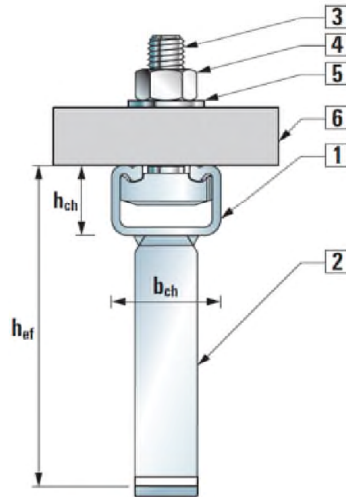

I-anchor

- fischer Anchor Channel  
FES-RS-S
- 1 Serrated channel profile
  - 2 Anchor
  - 3 Serrated channel bolt
  - 4 Hexagonal nut
  - 5 Washer
  - 6 Fixture

**Marking of the fischer anchor channel  
FES-RS-S:**

e. g.:  700

 = Identifying mark of the manufacturer

I = Additional marking for I-anchors  
No marking for round anchors

**Marking of the fischer channel bolt FBC-S:**

e. g.:  8.8 225

 = Identifying mark of the manufacturer

8.8 = Strength grade

225 = Width of anchor channel opening  $d_{ch}$

\* = Coating electro-plated  
No marking for hot dip galvanized

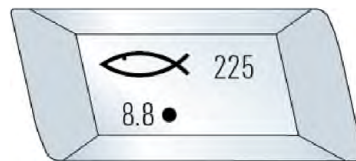
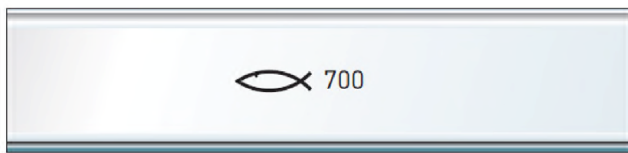

Stamped into back of channel

Optional: printed on channel web or channel lips

RS = Roll-shaped, S = Serrated

No marking for material acc. A7 Table 6 (Channel profile)

**fischer Serrated Anchor Channel InnoLock FES-RS-S with fischer Serrated Channel Bolts FBC-S**

**Product Description**  
Product and marking

Annex A2  
Appendix 5 / 23



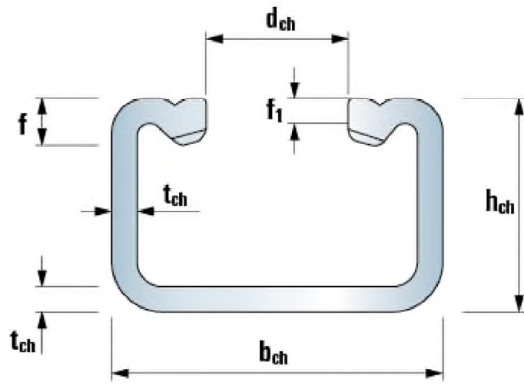

Serrated FES-RS-S-(I)-700

**Table 1: Dimensions of channel profile**

Anchor Channel FES-RS-S-(I)-	$b_{ch}$	$h_{ch}$	$t_{ch}$	$d_{ch}$	$f$	$f_1$	$I_y$
	[mm]	[mm]	[mm]	[mm]	[mm]	[mm]	[mm <sup>4</sup> ]
700	52,5	34,0	4,0	22,5	7,0	4,0	79168

fischer Serrated Anchor Channel InnoLock FES-RS-S with fischer Serrated Channel Bolts FBC-S

**Product Description**  
Dimensions of channels

Annex A3  
Appendix 6 / 23

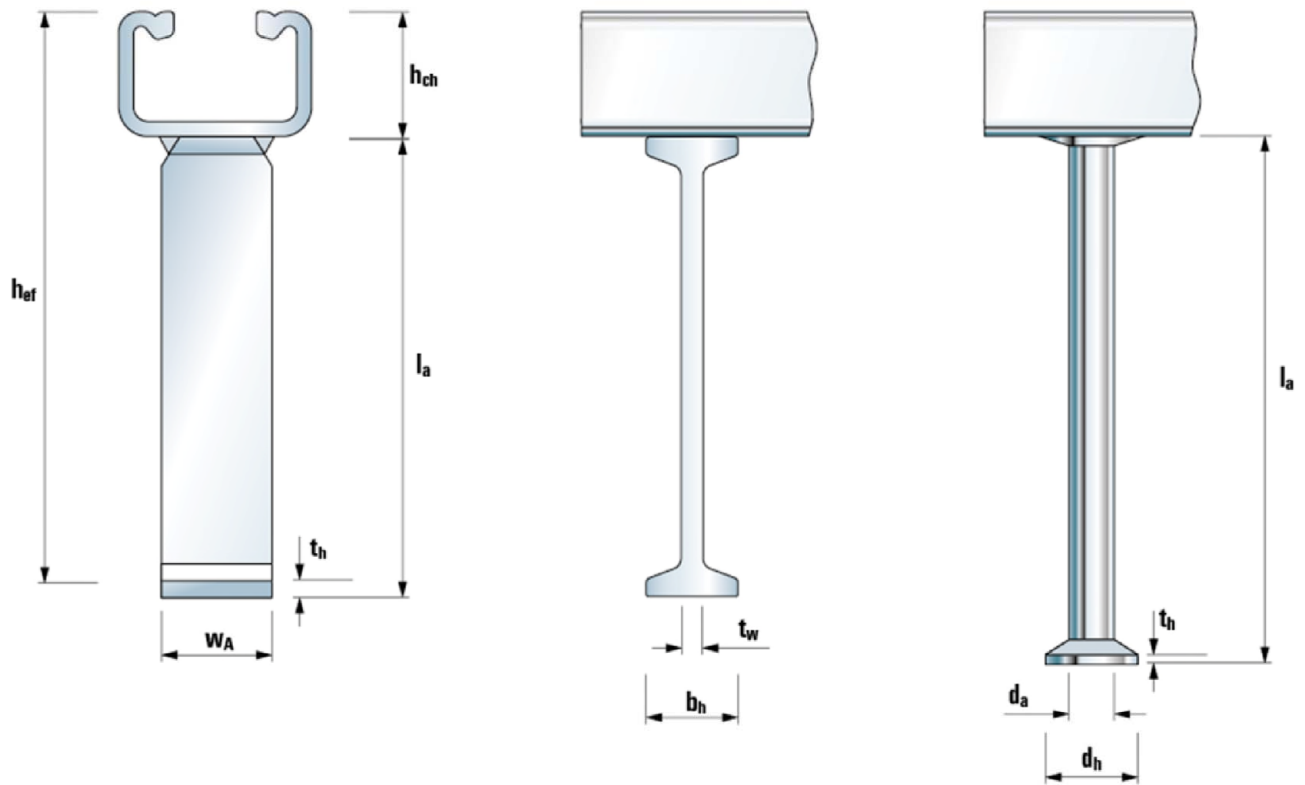

**Table 2: Dimensions of anchor (welded I-anchor or forged round anchor)**

Anchor Channel FES-RS-S-(I)-	I-anchor						Round anchor					
	$l_{a,min}$ [mm]	$t_{w,min}$ [mm]	$b_{h,min}$ [mm]	$t_h$ [mm]	$W_{A,min}$ [mm]	$A_{h,min}$ [mm <sup>2</sup> ]	$l_{a,min}$ [mm]	$d_a$ [mm]	$d_h$ [mm]	$t_h$ [mm]	$A_h$ [mm <sup>2</sup> ]	
700	125	6	25	5	30	570	144	12,8	26,0	3,0	402	

fischer Serrated Anchor Channel InnoLock FES-RS-S with fischer Serrated Channel Bolts FBC-S

**Product Description**  
Dimensions of anchors

Annex A4  
Appendix 7 / 23

**Table 3: Anchor position**

Anchor channel FES-RS-S-(I- )	Anchor type	S <sub>min</sub> [mm]	S <sub>max</sub> [mm]	X <sub>min</sub> [mm]	X <sub>max</sub> [mm]	l <sub>min</sub> [mm]	l <sub>max</sub> [mm]
700	round or I	100	250	30	35	160	6.070

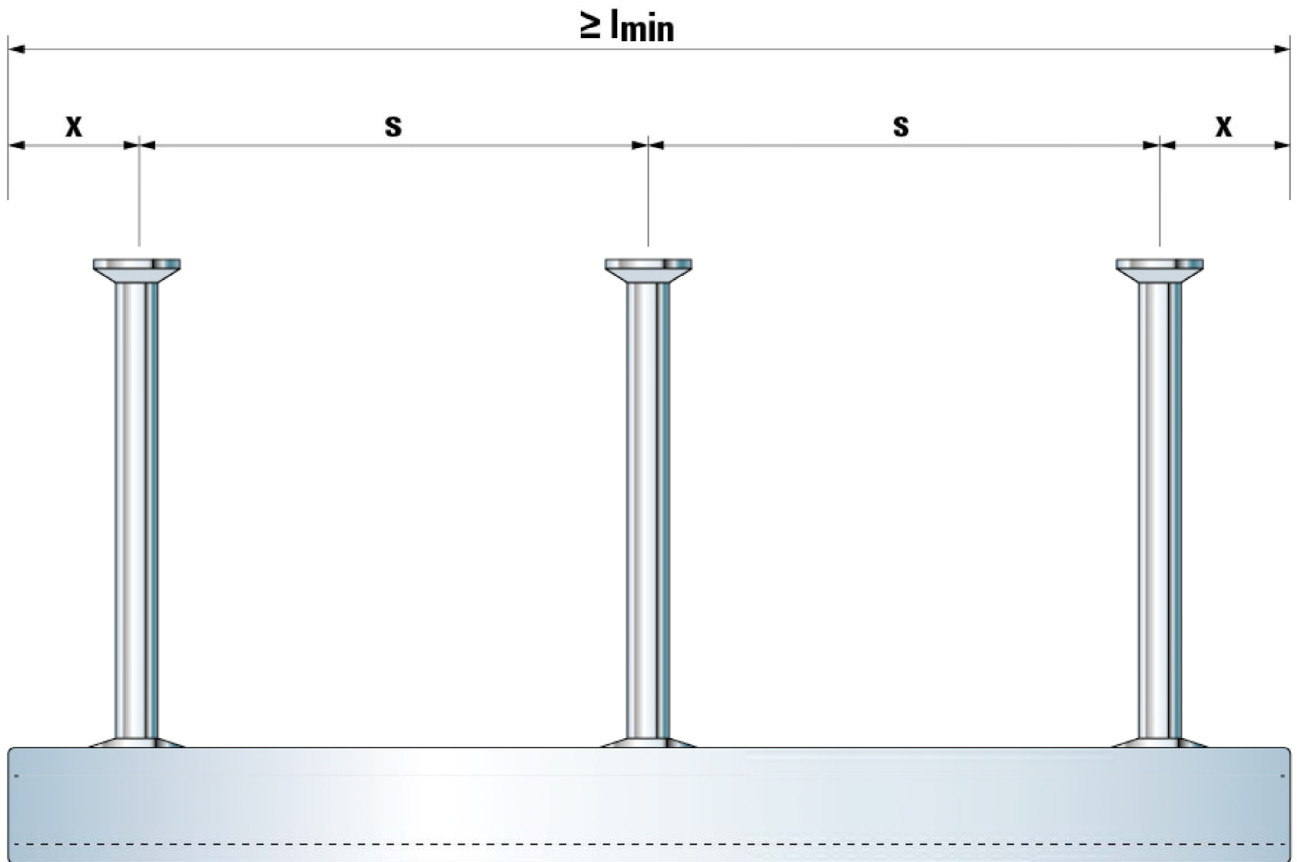

**fischer Serrated Anchor Channel InnoLock FES-RS-S with fischer Serrated Channel Bolts FBC-S**

**Product Description**

Anchor position and channel length

Annex A5

Appendix 8 / 23

**Table 4: Strength grade and corrosion class**

Channel Bolt	Carbon steel <sup>1)</sup>
Strength grade	8.8
$f_{uk}$ [N/mm <sup>2</sup> ]	800 / 830
$f_{yk}$ [N/mm <sup>2</sup> ]	640 / 660 <sup>2)</sup>
Corrosion protection	F <sup>3)</sup> or Electroplated

<sup>1)</sup> Material properties according to Annex A7

<sup>2)</sup> Material properties according to EN ISO 898-1: 2013

<sup>3)</sup> Hot-dip galvanized

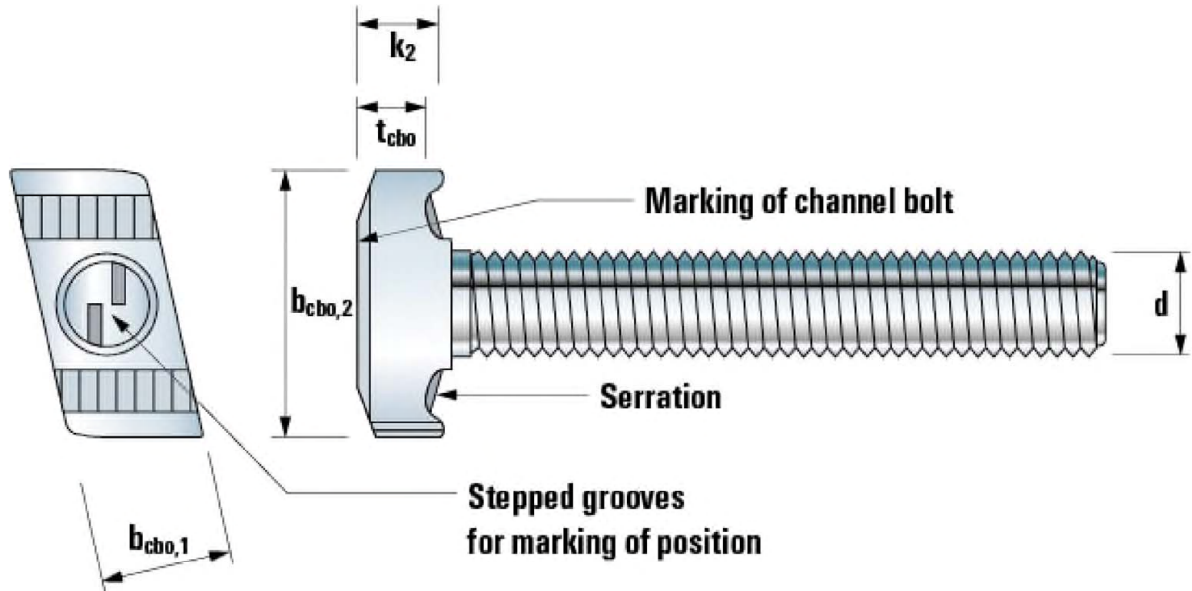

Serrated Channel Bolt FBC-S-225

**Table 5: Dimensions of fischer Channel Bolts FBC and matching fischer Anchor Channels FES**

Anchor Channel FES-RS-S-(I)-	Channel Bolt FBC-S-	Dimensions				
		d [mm]	$b_{cbo,1}$ [mm]	$b_{cbo,2}$ [mm]	$t_{cbo}$ [mm]	$k_2$ [mm]
700	225	12	21,0	43,0	10,7	15,0
		16				
		20				

fischer Serrated Anchor Channel InnoLock FES-RS-S with fischer Serrated Channel Bolts FBC-S

**Product Description**  
Channel bolts

Annex A6  
Appendix 9 / 23

**Table 6: Materials and properties**

Component	Carbon steel		
	Mechanical properties	Coating	Coating
1	2	2a	2b
Channel profile	1.0976 acc. to EN 10149:2004	Hot dip galvanized ≥ 50 µm acc. to EN ISO 10684:2004 + AC:2009	Hot dip galvanized ≥ 50 µm acc. to EN ISO 10684:2004 + AC:2009
Round anchor	1.5525 acc. to EN 10263:2017	Hot dip galvanized ≥ 50 µm acc. to EN ISO 10684:2004 + AC:2009	Hot dip galvanized ≥ 50 µm acc. to EN ISO 10684:2004 + AC:2009
I-anchor	1.0976 acc. to EN 10149:2004	Hot dip galvanized ≥ 50 µm acc. to EN ISO 10684:2004 + AC:2009	Hot dip galvanized ≥ 50 µm acc. to EN ISO 10684:2004 + AC:2009
Channel bolt	Strength grade 8.8 acc. to EN ISO 898-1:2013	Electroplated acc. to EN ISO 4042:2018	Hot dip galvanized ≥ 50 µm acc. to EN ISO 10684:2004 + AC:2009
Plain washer <sup>1)</sup> acc. to EN ISO 7089:2000 and EN ISO 7093- 1:2000	Hardness class A ≥ 200 HV	Electroplated acc. to EN ISO 4042:2018	Hot dip galvanized ≥ 50 µm acc. to EN ISO 10684:2004 + AC:2009
Hexagonal nut acc. to EN ISO 4032:2012	Property class 8 acc. to EN ISO 898-2:2012	Electroplated acc. to EN ISO 4042:2018	Hot dip galvanized ≥ 50 µm acc. to EN ISO 10684:2004 + AC:2009

<sup>1)</sup> Not in the scope of delivery

**fischer Serrated Anchor Channel InnoLock FES-RS-S with fischer Serrated Channel Bolts FBC-S**

**Product Description**  
Materials

Annex A7  
Appendix 10 / 23

## Specification for intended use

### Anchor channels and channel bolts subject to:

- Static and quasi-static tension, shear perpendicular to the longitudinal axis of the channel and shear in the direction of the longitudinal axis of the channel

### Base materials:

- Reinforced or unreinforced normal weight concrete according to EN 206-1:2000.
- Strength classes C12/15 to C90/105 according to EN 206-1:2000
- Cracked or uncracked concrete.

### Use conditions (Environmental conditions):

- Structures subject to dry internal conditions (anchor channels and channel bolts according to Annex A7, Table 6, column 2a and 2b).
- Structures subject to internal conditions with usual humidity (e.g. kitchens, bathrooms and laundries in residential buildings, exceptional permanent damp conditions and application under water) (anchor channels and channel bolts according to Annex A7, Table 6, column 2b).

### Design:

- Anchor channels are designed under the responsibility of an engineer experienced in anchorages and concrete work.
- Verifiable calculation notes and drawings are prepared taking account of the loads to be anchored. The position of the anchor channel and channel bolts are indicated on the design drawings (e.g. position of the anchor channel relative to the reinforcement or to supports).
- For static and quasi-static loading as well as fire exposure the anchor channels have to be designed in accordance with EOTA TR 047 "Design of Anchor Channels", March 2018 or EN 1992-4:2018.
- The characteristic resistances are calculated with the minimum effective embedment depth.

**fischer Serrated Anchor Channel InnoLock FES-RS-S with fischer Serrated Channel Bolts FBC-S**

**Intended Use**  
Specifications

Annex B1

Appendix 11 / 23

**Installation:**

- The installation of anchor channels is carried out by appropriately qualified personnel under the supervision of the person responsible for the technical matters on site.
- Use of the anchor channels only as supplied by the manufacturer - without any manipulations, repositioning or exchanging of channel components.
- Cutting of anchor channels is allowed only if pieces according to Annex A5, Table 3 are generated including end spacing  $x$  and minimum channel length  $l_{min}$  and only to be used in dry internal conditions.
- Installation in accordance with the installation instruction given in Annexes B5 and B6.
- The anchor channels are fixed on the formwork, reinforcement or auxiliary construction such that no movement of the channels will occur during the time of laying the reinforcement and of placing and compacting the concrete.
- The concrete around the head of the anchors is properly compacted. The channels are protected from penetration of concrete into the internal space of the channels.
- Washers may be chosen according to Annex A7 and provided separately by the user.
- Orientating the channel bolt (groove according to Annex B6, B7 and B8) rectangular to the channel axis.
- The required installation torque given in Annex B4 must be applied and must not be exceeded.

**fischer Serrated Anchor Channel InnoLock FES-RS-S with fischer Serrated Channel Bolts FBC-S**

**Intended Use**  
Specification

Annex B2

Appendix 12 / 23

**Table 7: Installation parameters**

Anchor Channel FES-RS-S-			700	I-700
Minimum effective embedment depth	$h_{ef,min}$	[mm]	175	154
Minimum edge distance	$c_{min}$		75	75
Minimum thickness of concrete member	$h_{min}$		178	178

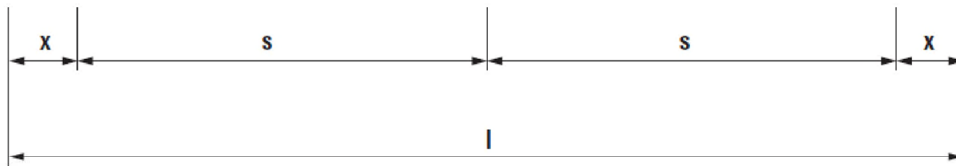
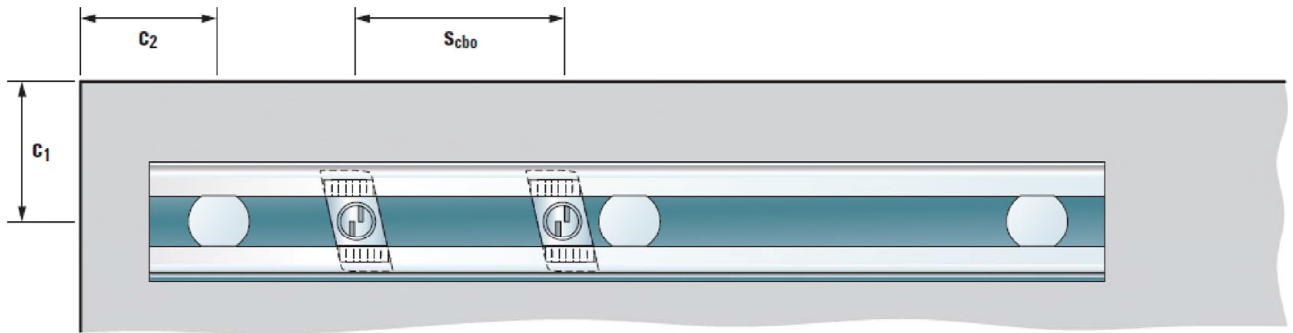

**Table 8: Minimum spacing for channel bolts**

Channel bolt			M12	M16	M20
Minimum spacing between channel bolts	$S_{cbo,min}$	[mm]	60	80	100

**fischer Serrated Anchor Channel InnoLock FES-RS-S with fischer Serrated Channel Bolts FBC-S**

**Intended Use**

Installation parameters for fischer Anchor Channels FES

Annex B3  
Appendix 13 / 23



**Table 9: Installation torque  $T_{inst}$**

fischer Anchor channel FES-RS-S-(I)-	fischer Channel Bolt FBC-S-	Thread diameter	$T_{inst}^{1)}$ [Nm]	
			General $T_{inst,g}$	Steel - steel contact $T_{inst,s}$
			8.8	8.8
700	225	M12	80	100
		M16	100	200
		M20	120	360

<sup>1)</sup>  $T_{inst}$  must not be exceeded

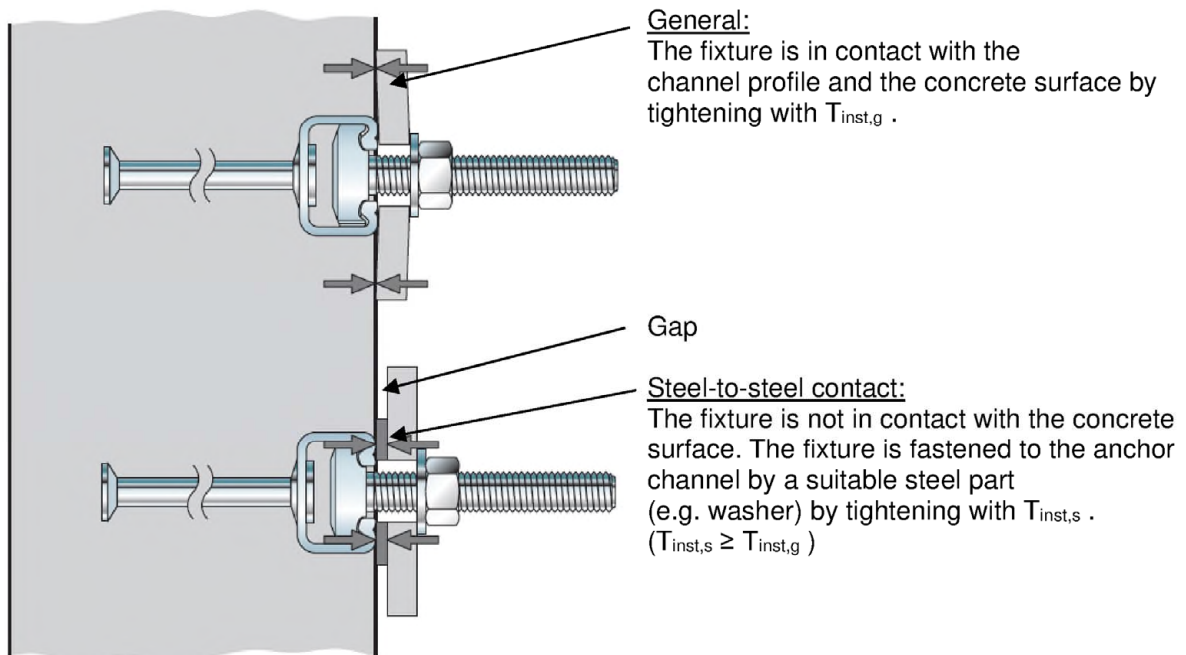

**fischer Serrated Anchor Channel InnoLock FES-RS-S with fischer Serrated Channel Bolts FBC-S**

**Intended Use**

Installation parameters for fischer Channel Bolts FBC

Annex B4

Appendix 14 / 23

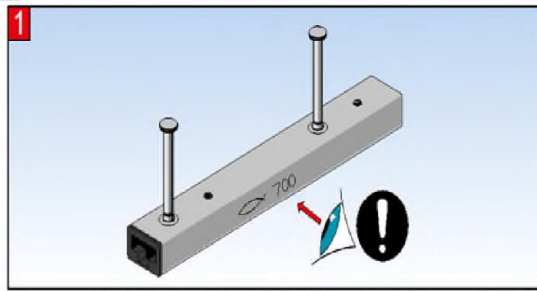

2

X	T
30-35mm	FES-RS-S
	700

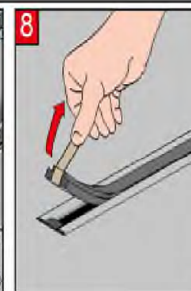
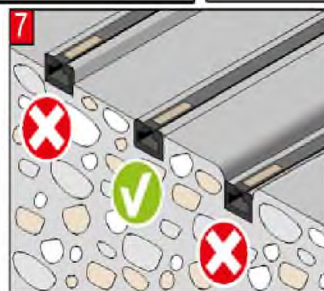
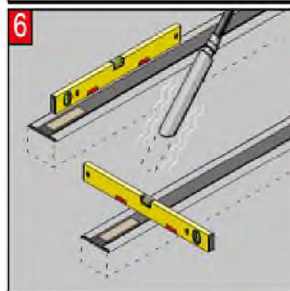
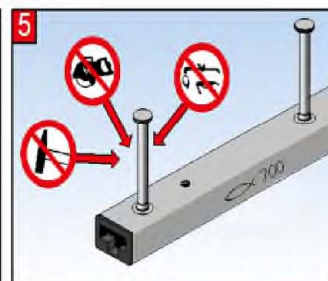
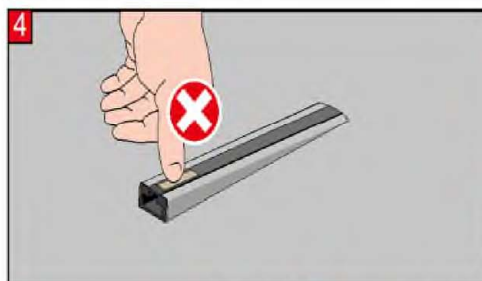
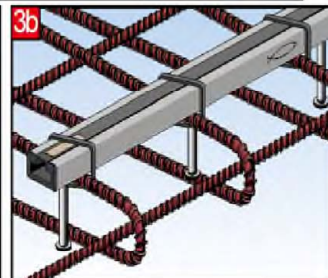
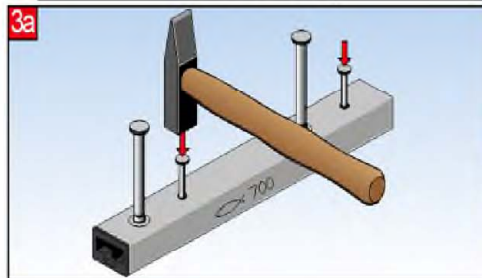

**fischer Serrated Anchor Channel InnoLock FES-RS-S with fischer Serrated Channel Bolts FBC-S**

**Intended Use**  
Installation instruction for fischer Anchor Channels FES

Annex B5  
Appendix 15 / 23

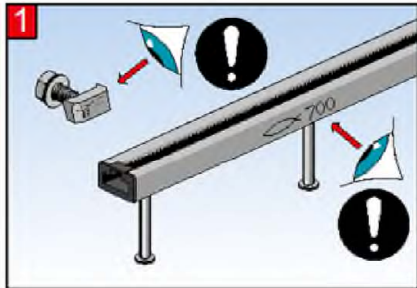

↓		T	
FBC-S-	FES-RS-S		
225	700		

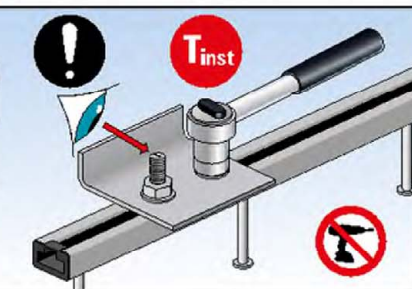
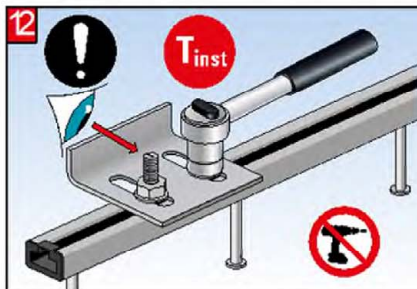
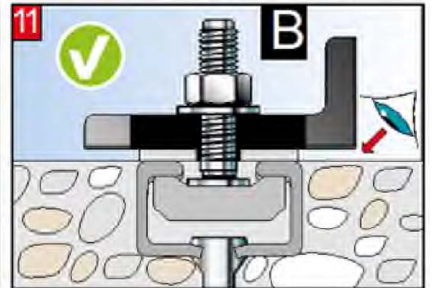
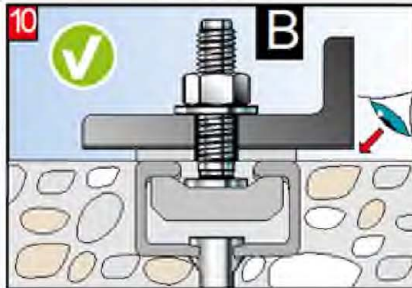
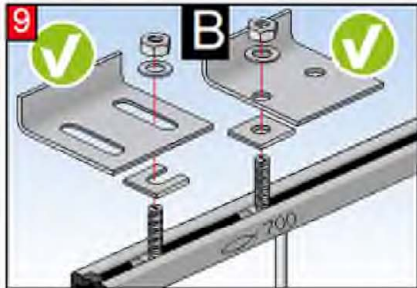
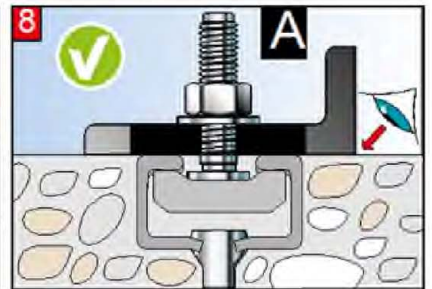
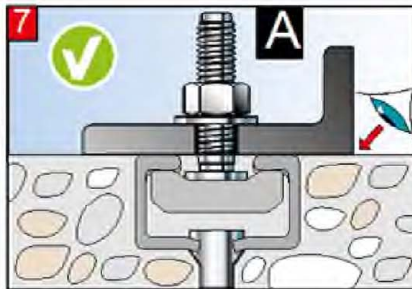
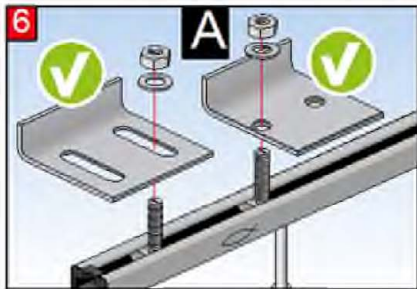
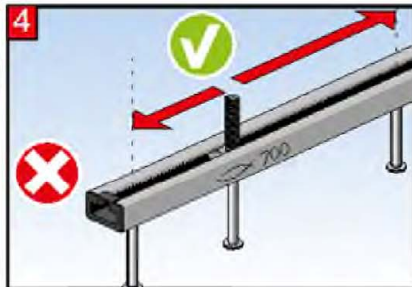
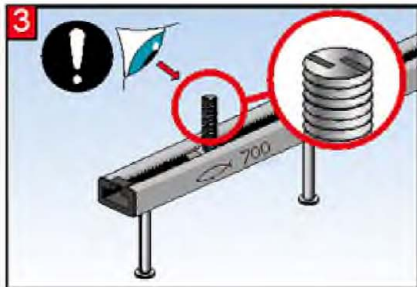
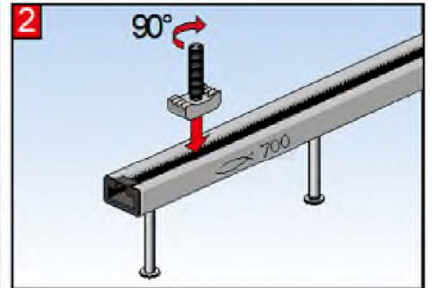

FBC-S-	FES-RS-S-	T <sub>inst</sub> [Nm]	M12	M16	M20
225	700	A	80	100	120
		B	100	200	360

T<sub>inst</sub> must not be exceeded.

fischer Serrated Anchor Channel InnoLock FES-RS-S with fischer Serrated Channel Bolts FBC-S

### Intended Use

Installation instruction for Serrated fischer Channel Bolts FBC-S

Annex B6

Appendix 16 / 23

**Table 10: Characteristic resistances under tension load – steel failure of anchor channels**

Anchor Channel FES-RS-S-			700	I-700
<b>Steel failure: Anchor</b>				
Characteristic resistance	$N_{Rk,s,a}$	[kN]	73,3	81,0
Partial factor	$\gamma_{Ms}^1$	[-]	1,8	
<b>Steel failure: Connection between anchor and channel</b>				
Characteristic resistance	$N_{Rk,s,c}$	[kN]	73,0	80,0
Partial factor	$\gamma_{Ms}^1$	[-]	1,8	
<b>Steel failure: Local flexure of channel lips</b>				
Characteristic spacing of channel bolts for $N_{Rk,s,l}$	$S_{l,N}$	[mm]	105	
Characteristic resistance	$N^0_{Rk,s,l}$	[kN]	80	
Partial factor	$\gamma_{Ms}^1$	[-]	1,8	

<sup>1)</sup>In absence of other national regulations

**Table 11: Characteristic flexural resistance of channel**

Anchor Channel FES-RS-S-(I)-			700
<b>Steel failure: Flexure of channel</b>			
Characteristic flexural resistance of channel	$M_{Rk,s,flex}$	[Nm]	3749
Partial factor	$\gamma_{Ms,flex}^1$	[-]	1,15

<sup>1)</sup>In absence of other national regulations

**fischer Serrated Anchor Channel InnoLock FES-RS-S with fischer Serrated Channel Bolts FBC-S**

Annex C1

**Performance**

Characteristic resistances of anchor channels under tension load – Steel failure of anchor channel

Appendix 17 / 23

**Table 12: Characteristic resistances under tension load – concrete failure**

Anchor Channel FES-RS-S-			700	I-700
<b>Concrete failure: Pull-out failure</b>				
Characteristic resistance in cracked concrete C12/15	$N_{Rk,p}$	[kN]	36,2	51,3
Characteristic resistance in uncracked concrete C12/15	$N_{Rk,p}$	[kN]	50,7	71,8
Increasing factor of $N_{Rk,p} = N_{Rk,p}(C12/15) * \psi_c$	C16/20 C20/25 C25/30 C30/37 C35/45 C40/50 C45/55 C50/60 C55/67 $\geq C60/75$	$\psi_c$ [-]	1,33 1,67 2,08 2,50 2,92 3,33 3,75 4,17 4,58 5,00	
Partial factor	$\gamma_{Mp} = \gamma_{Mc}^{1)}$	[-]	1,5	
<b>Concrete failure: Concrete cone failure</b>				
Product factor $k_1$	$k_{cr,N}$	[-]	8,9	8,7
	$k_{ucr,N}$	[-]	12,6	12,5
Partial factor	$\gamma_{Mc}^{1)}$	[-]	1,5	
<b>Concrete failure: Concrete splitting failure</b>				
Characteristic edge distance	$c_{cr,sp}$	[mm]	525	477
Characteristic spacing	$s_{cr,sp}$	[mm]	1050	954
Partial factor	$\gamma_{Msp} = \gamma_{Mc}^{1)}$	[-]	1,5	

<sup>1)</sup> In absence of other national regulations

**fischer Serrated Anchor Channel InnoLock FES-RS-S with fischer Serrated Channel Bolts FBC-S**

**Performance**  
Characteristic resistances under tension load – concrete failure

Annex C2

Appendix 18 / 23

**Table 13: Displacements under tension load**

Anchor Channel FES-RS-S-(I)-			700
Tension load	N	[kN]	31,7
Short-term displacement <sup>1)</sup>	$\delta_{N0}$	[mm]	2,1
Long-term displacement <sup>1)</sup>	$\delta_{N\infty}$	[mm]	4,2

<sup>1)</sup> Displacements in midspan of the anchor channel, including slip of channel bolt, deformation of channel lips, bending of the channel and slip of the anchor channel in concrete

**fischer Serrated Anchor Channel InnoLock FES-RS-S with fischer Serrated Channel Bolts FBC-S**

**Performance**  
Displacement under tension load

Annex C3  
Appendix 19 / 23

**Table 14: Characteristic resistances under shear load – steel failure of anchor channels**

Anchor Channel FES-RS-S-			700	I-700
<b>Steel failure: Anchor</b>				
Characteristic resistance	$V_{Rk,s,a,y}$	[kN]	120,0	120,0
	$V_{Rk,s,a,x}$	[kN]	44,0	48,6
Partial factor	$\gamma_{Ms}^{1)}$	[-]	1,8	
<b>Steel failure of connection between anchor and channel</b>				
Characteristic resistance	$V_{Rk,s,c,y}$	[kN]	120,0	120,0
	$V_{Rk,s,c,x}$	[kN]	43,8	48,0
Partial factor	$\gamma_{Ms}^{1)}$	[-]	1,8	
<b>Steel failure: Local flexure of channel lips</b>				
Characteristic spacing of channel bolts for $V_{Rk,s,l}$	$s_{l,v}$	[mm]	105	
Characteristic resistance	$V^0_{Rk,s,l,y}$	[kN]	92,0	
Partial factor	$\gamma_{Ms}^{1)}$	[-]	1,8	

<sup>1)</sup> In absence of other national regulations

**fischer Serrated Anchor Channel InnoLock FES-RS-S with fischer Serrated Channel Bolts FBC-S**

Characteristic resistance of anchor channel under shear load - steel failure of anchor channel

Annex C4  
Appendix 20 / 23



**Table 15: Characteristic resistance for shear load in direction of the longitudinal axis of the channel – steel failure**

<b>Anchor Channel FES-RS-S-(I)-</b>			<b>700</b>	
<b>Steel failure: Connection between channel lips and serrated channel bolt</b>				
Characteristic resistance	$V_{Rk,s,l,x}$	[kN]	FBC-S-225-M12-8.8	.. <sup>2)</sup>
			FBC-S-225-M16-8.8	22,5
			FBC-S-225-M20-8.8	22,5
Installation factor	$\gamma_{inst}$ <sup>1)</sup>	[-]		1,2

<sup>1)</sup> In absence of other national regulations

<sup>2)</sup> No performance assessed.

**Table 16: Characteristic resistances of the anchor channel under shear load – concrete failure**

<b>Anchor Channel FES-RS-S-(I)-</b>			<b>700</b>	
<b>Concrete failure: Pry-out failure</b>				
Product factor		$k_B$	[-]	2,0
Partial factor		$\gamma_{Mc}$ <sup>1)</sup>	[-]	1,5
<b>Concrete failure: Concrete edge failure</b>				
Product factor $k_{12}$	Cracked concrete	$k_{cr,v}$	[-]	7,5
	Uncracked concrete	$k_{ucr,v}$	[-]	10,5
Partial factor		$\gamma_{Mc}$ <sup>1)</sup>	[-]	1,5

<sup>1)</sup> In absence of other national regulations

**fischer Serrated Anchor Channel InnoLock FES-RS-S with fischer Serrated Channel Bolts FBC-S**

**Performance**  
Characteristic resistance of anchor channel under shear load

Annex C5  
Appendix 21 / 23



**Table 17: Displacements under shear load**

Anchor Channel FES-RS-S-(I)-			700
Shear load perpendicular to the longitudinal axis of the channel	$V_y$	[kN]	36,5
Short-term displacement <sup>1)</sup>	$\delta_{V,y,0}$	[mm]	2,9
Long-term displacement <sup>1)</sup>	$\delta_{V,y,\infty}$	[mm]	4,4
Shear load in direction of the longitudinal axis of the channel	$V_x$	[kN]	6,6
Short-term displacement <sup>2)</sup>	$\delta_{V,x,0}$	[mm]	1,2
Long-term displacement <sup>2)</sup>	$\delta_{V,x,\infty}$	[mm]	1,8

<sup>1)</sup> Displacements in midspan of the anchor channel, including slip of channel bolt, deformation of channel lips and slip of the anchor channel in concrete

<sup>2)</sup> Displacements of the anchor channel, including slip of channel bolt, deformation of channel lips and slip of the anchor channel in concrete.

**Table 18: Characteristic resistances under tension and shear load – steel failure of channel bolts**

Channel bolt FBC-S-225			M12	M16	M20
<b>Steel failure:</b>			Steel grade 8.8		
Characteristic resistance	$N_{Rk,s}$	[kN]	67,4	125,6	170,0
Partial factor	$\gamma_{Ms}$ <sup>1)</sup>	[-]	1,5		
Characteristic resistance	$V_{Rk,s}$	[kN]	33,7	62,8	98,0
Partial factor	$\gamma_{Ms}$ <sup>1)</sup>	[-]	1,25		

<sup>1)</sup> In absence of other national regulations

**Table 19: Characteristic resistances under combined tension and shear load**

Anchor Channel FES-RS-S-(I)-			700
<b>Steel failure: Local flexure of channel lips and flexure of channel</b>			
Product factor	$k_{13}$	[-]	according to EN 1992-4:2018, 7.4.3.1
<b>Steel failure: Anchor and connection between anchor and channel</b>			
Product factor	$k_{14}$	[-]	according to EN 1992-4:2018, 7.4.3.1

**fischer Serrated Anchor Channel InnoLock FES-RS-S with fischer Serrated Channel Bolts FBC-S**

**Performance**

Characteristic resistance of channel bolts under tension and shear load,  
Displacements under shear load, combined tension and shear load

Annex C6

Appendix 22 / 23

**Table 20: Characteristic resistances under shear load with lever arm – steel failure of channel bolts**

Channel bolt thread diameter <sup>2)</sup>				M12	M16	M20
<b>Steel failure</b>						
Characteristic flexural resistance	$M^{0}_{Rk,s}$	[Nm]	FBC-S-225	104,8	266,4	519,3
Partial factor	$\gamma_{Ms}$ <sup>1)</sup>	[-]	FBC-S-225	1,25		
Internal lever arm	a	[mm]	FBC-S-225	29,8	31,8	34,2

<sup>1)</sup> In absence of other national regulations

<sup>2)</sup> Materials according to Annex A7, Table 6

The characteristic flexure resistance according to Table 19 is limited as follows:

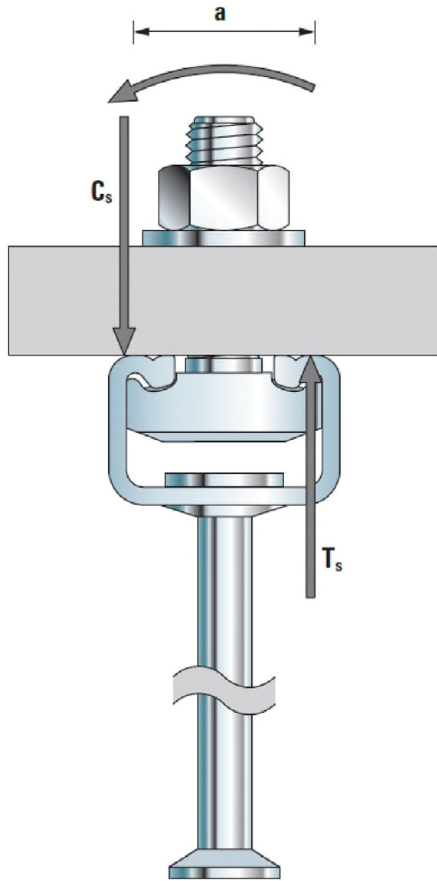

$$M^{0}_{Rk,s} \leq 0,5 \cdot N^{0}_{Rk,s,l} \cdot a \quad (N^{0}_{Rk,s,l} \text{ according to Annex C1, Table 10})$$

$$M^{0}_{Rk,s} \leq 0,5 \cdot N_{Rk,s} \cdot a \quad (N_{Rk,s} \text{ according to Annex C5, Table 18})$$

a = Internal lever arm according to Table 19

$T_s$  = Tension force acting on the channel lips

$C_s$  = Compression force acting on the channel lips

**fischer Serrated Anchor Channel InnoLock FES-RS-S with fischer Serrated Channel Bolts FBC-S**

**Performance**

Characteristic flexural resistances of channel bolts under shear load

Annex C7