

ΔΗΛΩΣΗ ΕΠΙΔΟΣΕΩΝ

DoP 0382

για fischer Bolt Anchor FBN II HDG (Εκτομούμενα αγκύρια για χρήση σε μπετόν)

EL

- | | |
|---|---|
| 1. <u>Μοναδικός κωδικός ταυτοποίησης του τύπου του προϊόντος:</u> | DoP 0382 |
| 2. <u>Προβλεπόμενη(-ες) χρήση(-εις):</u> | Μεταγενέστερη στερέωση σε μη ρηγματωμένο σκυρόδεμα, δείτε το παράρτημα, ειδικά τα παραρτήματα B1-B5. |
| 3. <u>Κατασκευαστής:</u> | fischerwerke GmbH & Co. KG, Klaus-Fischer-Str. 1, 72178 Waldachtal, Γερμανία |
| 4. <u>Εξουσιοδοτημένος αντιπρόσωπος:</u> | - |
| 5. <u>Σύστημα/συστήματα AVCP (αξιολόγηση και επαλήθευση της σταθερότητας της επίδοσης):</u> | 1 |
| 6. <u>Ευρωπαϊκό έγγραφο αξιολόγησης:</u> | EAD 330232-01-0601-v01 |
| Ευρωπαϊκή τεχνική αξιολόγηση: | ETA-18/0101; 2025-07-03 |
| Οργανισμός τεχνικής αξιολόγησης: | ETA-Danmark A/S |
| Κοινοποιημένος(-οι) οργανισμός(-οι): | 2873 TU Darmstadt |

7. Δηλωθείσα(-ες) επίδοση(-εις):

Μηχανική αντίσταση και σταθερότητα (BWR1)

Χαρακτηριστική αντίσταση σε εφελκυστικό φορτίο (στατικό και σχεδόν στατικό) μέθοδος A:

Αντίσταση σε αστοχία χάλυβα: Παράρτημα C1

Αντίσταση σε αστοχία από εξόλκευση: Παράρτημα C1

Αντίσταση σε αστοχία από κώνο σκυροδέματος: Παράρτημα C1

Ανθεκτικότητα: δείτε το παράρτημα, ειδικά τα Παράρτημα C1, C2

Ελάχιστη απόσταση από ακμή και μεταξύ αγκυρίων: Παράρτημα B5

Απόσταση από ακμή για αποφυγή θραύσης από φορτίο: - NPD

Χαρακτηριστική αντίσταση σε διατμητικό φορτίο (στατικό και σχεδόν στατικό) μέθοδος A:

Αντίσταση σε αστοχία χάλυβα (διατμητικό φορτίο): Παράρτημα C2

Αντίσταση σε ολίσθηση: Παράρτημα C2

Χαρακτηριστική αντίσταση για απλοποιημένο σχεδιασμό:

Μέθοδος B: NPD

Μέθοδος C: NPD

Μετατόπιση:

Μετατοπίσεις υπό στατικό και σχεδόν στατικό φορτίο: Παράρτημα C2

Ασφάλεια σε περίπτωση φωτιάς (BWR 2)

Αντίδραση σε φωτιά: NPD

Αντίσταση στη φωτιά:

Αντίσταση σε φωτιά για αστοχία χάλυβα (εφελκυστικό φορτίο): NPD

Αντίσταση σε φωτιά για εξόλκευση (εφελκυστικό φορτίο): NPD

Αντίσταση σε φωτιά για αστοχία χάλυβα (διατμητικό φορτίο): NPD

Διάρκεια:

Διάρκεια: Παράρτημα A3, B1-B3

8. Κατάλληλη τεχνική τεκμηρίωση και/ή ειδική τεχνική τεκμηρίωση:

-

Η επίδοση του προϊόντος που ταυτοποιείται ανωτέρω είναι σύμφωνη με τη (τις) δηλωθείσα(-ες) επίδοση(-εις). Αυτή η δήλωση επιδόσεων εκδίδεται σύμφωνα με τον Κανονισμό (ΕΕ) Αρ. 305/2011 με αποκλειστική ευθύνη του κατασκευαστή που προσδιορίζεται παραπάνω.

Υπογραφή για λογαριασμό και εξ ονόματος του κατασκευαστή από:

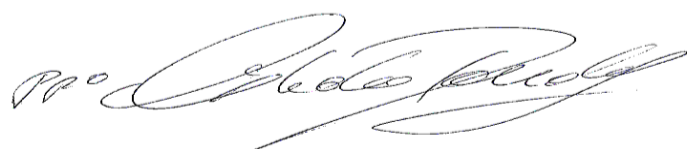

Dr. Ronald Mihala, Διευθύνων Σύμβουλος Έρευνας και Ανάπτυξης
Tumlingen, 2025-08-01



Dieter Pfaff, Επικεφαλής της Διεθνούς Ομοσπονδίας Παραγωγής και Διαχείρισης Ποιότητας

Αυτή η Δήλωση Επιδόσεων μεταφράστηκε σε διάφορες γλώσσες. Σε περίπτωση που υπάρχει αμφιβολία για τη μετάφραση, υπερισχύει πάντα η αγγλική έκδοση.

Το παράρτημα περιλαμβάνει προαιρετικές και συμπληρωματικές πληροφορίες στα αγγλικά, που ξεπερνούν τις (οριζόμενες σε άλλες γλώσσες) νόμιμες απαιτήσεις.

Translation guidance Essential Characteristics and Performance Parameters for Annexes

Οδηγίες Μετάφρασης των βασικών χαρακτηριστικών και απόδοσης για τα παραρτήματα

Mechanical resistance and stability (BWR 1)		
Μηχανική αντίσταση και σταθερότητα (BWR1)		
Characteristic resistance under static and quasi-static loading, Method A		
Χαρακτηριστική αντίσταση σε εφελκυστικό φορτίο (στατικό και σχεδόν στατικό) μέθοδος Α:		
1	Resistance to steel failure: Αντίσταση σε αστοχία χάλυβα:	$N_{Rk,s}$ [kN], E_s [N/mm ²]
2	Resistance to pull-out failure: Αντίσταση σε αστοχία από εξόλκευση:	$N_{Rk,p}$ [kN], ψ_c
3	Resistance to concrete cone failure: Αντίσταση σε αστοχία από κώνο σκυροδέματος:	$k_{cr,N}$, $k_{ucr,N}$ [-], h_{ef} , $c_{cr,N}$ [mm]
4	Robustness: Ανθεκτικότητα:	γ_{inst} [-]
5	Minimum edge distance and spacing: Ελάχιστη απόσταση από ακμή και μεταξύ αγκυριών:	c_{min} , s_{min} , h_{min} [mm]
6	Edge distance to prevent splitting under load: Απόσταση από ακμή για αποφυγή θραύσης από φορτίο:	$N^0_{Rk,sp}$ [kN], $c_{cr,sp}$ [mm]
Characteristic resistance to shear load (static and quasi-static loading), Method A		
Χαρακτηριστική αντίσταση σε διατμητικό φορτίο (στατικό και σχεδόν στατικό) μέθοδος Α:		
7	Resistance to steel failure under shear load: Αντίσταση σε αστοχία χάλυβα (διατμητικό φορτίο):	$V^0_{Rk,s}$ [kN], $M^0_{Rk,s}$ [Nm], k_7 [-]
8	Resistance to pry-out failure: Αντίσταση σε ολίσθηση:	k_8 [-]
Characteristic Resistance for simplified design		
Χαρακτηριστική αντίσταση για απλοποιημένο σχεδιασμό:		
9	Method B: Μέθοδος Β:	F^0_{Rk} [kN], c_{cr} , s_{cr} [mm]
10	Method C: Μέθοδος C:	F_{Rk} [kN]
Displacements		
Μετατόπιση:		
11	Displacements under static and quasi-static loading: Μετατοπίσεις υπό στατικό και σχεδόν στατικό φορτίο:	δ_{N0} , $\delta_{N\infty}$, δ_{V0} , $\delta_{V\infty}$ [mm]
Safety in case of fire (BWR 2)		
Ασφάλεια σε περίπτωση φωτιάς (BWR 2)		
12	Reaction to fire: Αντίδραση σε φωτιά:	Class
Resistance to fire:		
Αντίσταση στη φωτιά:		
13	Fire resistance to steel failure (tension load): Αντίσταση σε φωτιά για αστοχία χάλυβα (εφελκυστικό φορτίο):	$N_{Rk,s,fi}$ [kN]
14	Fire resistance to pull-out failure (tension load): Αντίσταση σε φωτιά για εξόλκευση (εφελκυστικό φορτίο):	$N_{Rk,p,fi}$ [kN]
15	Fire resistance to steel failure (shear load): Αντίσταση σε φωτιά για αστοχία χάλυβα (διατμητικό φορτίο):	$V_{Rk,s,fi}$ [kN], $M^0_{Rk,s,fi}$ [Nm]
Aspects of durability		
Διάρκεια:		
16	Durability: Διάρκεια:	Class

II SPECIFIC PART OF THE EUROPEAN TECHNICAL ASSESSMENT

1 Technical description of product

The Fischer Bolt anchor FBN II HDG is an anchor made of zinc plated, hot-dip galvanised steel which is placed into a drilled hole and anchored by torque controlled expansion. The thickness of the corrosion protection layer is minimum 40 µm with a batch average of minimum 50 µm

Product and product description is given in Annex A.

The characteristic material values, dimensions and tolerances of the anchors not indicated in Annexes shall correspond to the respective values laid down in the technical documentation of this European Technical Assessment.

The anchors are intended to be used with embedment depth given in Annex B, Table B4.1. The intended use specifications of the product are detailed in Annex B1.

2 Specification of the intended use(s) in accordance with the applicable European Assessment Document (hereinafter EAD)

The performances given in Section 3 are only valid if the anchor is used in compliance with the specifications and conditions given in Annex B.

The provisions made in this European Technical Assessment are based on an assumed intended working life of the anchor as given in Annex B depending on the corrosion protection.

The indications given on the working life cannot be interpreted as a guarantee given by the producer or Assessment Body, but are to be regarded only as a means for choosing the right products in relation to the expected economically reasonable working life of the works.

3 Performance of the product and references to the methods used for its assessment

3.1 Characteristics of product

Mechanical resistance and stability (BWR 1):

The essential characteristics are detailed in the Annex from C1 to C2.

Safety in case of fire (BWR 2):

No Performance assessed.

3.2 Methods of assessment

The assessment of fitness of the anchor for the intended use in relation to the requirements for mechanical resistance and stability and safety in use in the sense of the Basic Works Requirements 1 and 4 has been made in accordance with EAD 330232-01-0601-v01; Mechanical fasteners for use in concrete.

4 Assessment and verification of constancy of performance (hereinafter AVCP) system applied, with reference to its legal base

4.1 AVCP system

According to the decision 1996/582/EC of the European Commission, the system(s) of assessment and verification of constancy of performance (see Annex V to Regulation (EU) No 305/2011) is 1.

5 Technical details necessary for the implementation of the AVCP system, as provided for in the applicable EAD

Technical details necessary for the implementation of the AVCP system are laid down in the control plan deposited at ETA-Danmark prior to CE marking

Cone bolt manufactured by cold - forming:

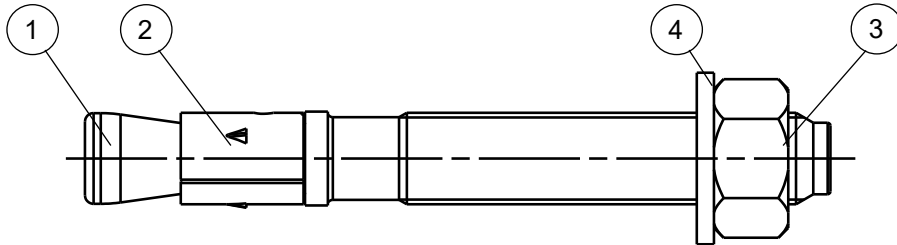

Cone bolt manufactured by turning:

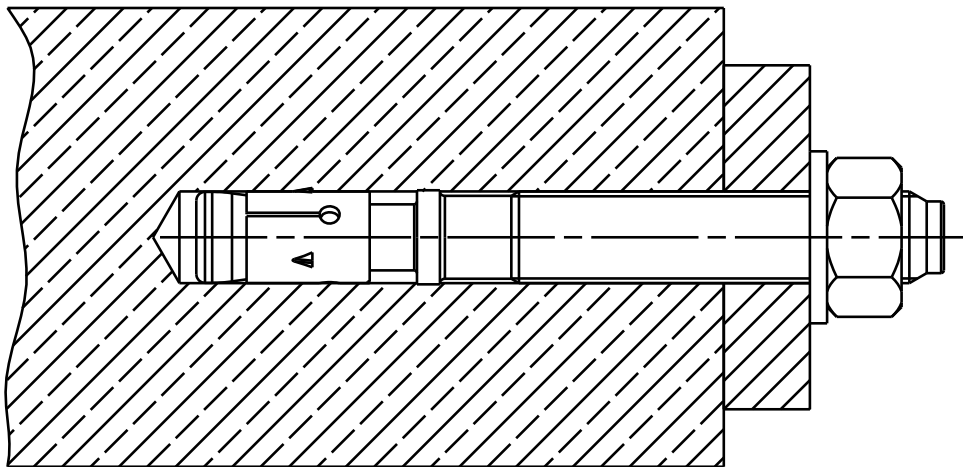
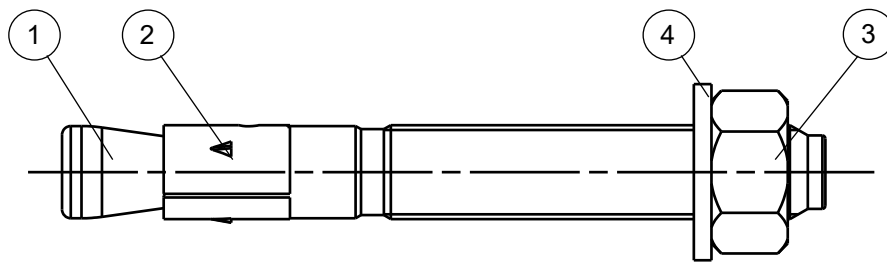

- ① Cone bolt (cold – formed or turned)
- ② Expansion sleeve
- ③ Hexagon nut
- ④ Washer

(Fig. not to scale)

fischer Bolt Anchor hot-dip galvanised FBN II HDG

Annex A1
Appendix 4 / 13

Product description
Installed condition

FBN II HDG for use with standard and reduced embedment depth ($h_{ef, sta}$ and $h_{ef, red}$)

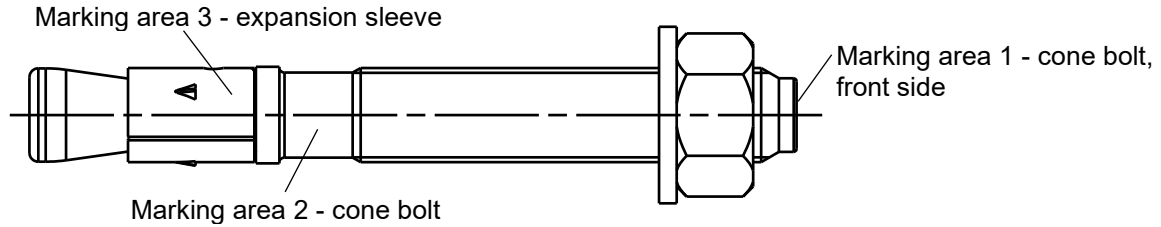

Product label, example:

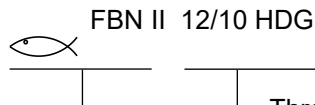

Brand | type of fastener placed at marking area 2 or marking area 3

Thread Size / max. thickness of fixture (t_{fix}) for $h_{ef, sta}$ placed at marking area 2

Table A2.1: Letter-code on marking area 1 and maximum thickness of fixture t_{fix}

Marking		A	B	C	D	E	F	G	H	I	K	L	M	N	O	P	R	S	T	U	V	W	X	Y	Z
Max. t_{fix} for $h_{ef, sta}$	M8-M20	5	10	15	20	25	30	35	40	45	50	60	70	80	90	100	120	140	160	180	200	250	300	350	400
Max. t_{fix} for $h_{ef, red}$	M8, M10	15	20	25	30	35	40	45	50	55	60	70	80	90	100	110	130	150	170	190	210	260	310	360	410
	M12, M16	20	25	30	35	40	45	50	55	60	65	75	85	95	105	115	135	155	175	195	215	265	315	365	415
	M20	30	35	40	45	50	55	60	65	70	75	85	95	105	115	125	145	165	185	205	225	275	325	375	425

FBN II K HDG for use with reduced embedment depth only ($h_{ef, red}$):

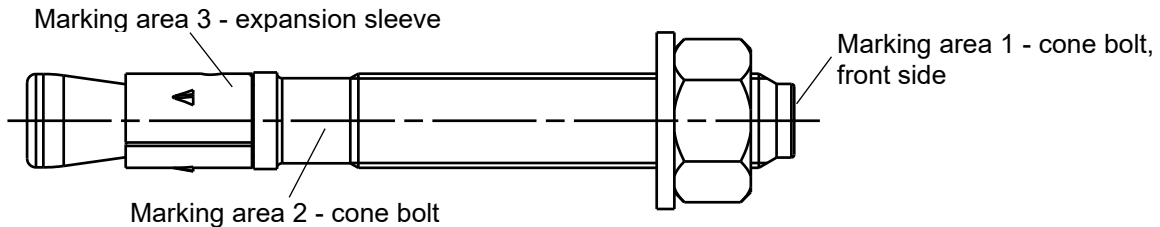

Product label, example:

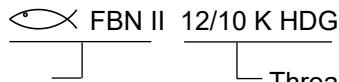

Brand | type of fastener placed at marking area 2 or marking area 3

Thread Size / max. thickness of fixture (t_{fix}) identification K for $h_{ef, red}$ placed at marking area 2

Table A2.2: Letter-code on marking area 1 and maximum thickness of fixture t_{fix}

Marking		-A-	-B-	-C-	-D-	-E-	-F-	-G-	-H-	-I-	-K-	-L-	-M-	-N-	-O-	-P-	-R-	-S-	-T-	-U-	-V-	-W-	-X-	-Y-	-Z-
Max. t_{fix} for $h_{ef, red}$	M8-M20	5	10	15	20	25	30	35	40	45	50	60	70	80	90	100	120	140	160	180	200	250	300	350	400

(Fig. not to scale)

fischer Bolt Anchor hot-dip galvanised FBN II HDG	Annex A2 Appendix 5 / 13
Product description Anchor types	

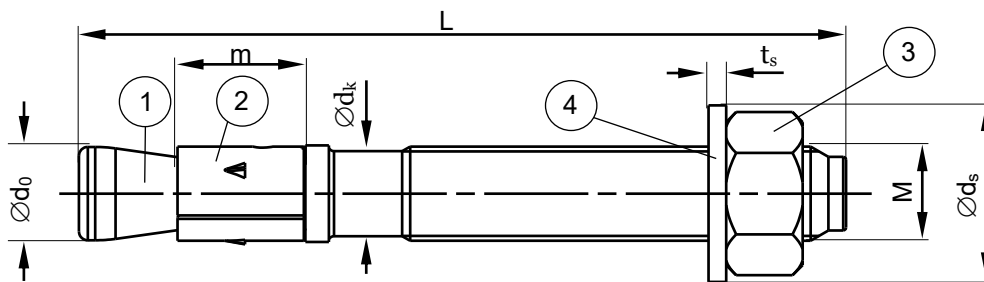

Table A3.1: Anchor dimensions [mm]

Part	Designation	M8	M10	M12	M16	M20	
1	Cone bolt	$\varnothing d_0$	7,9	9,9	11,9	15,9	19,6
		$\varnothing d_k$	7,1	8,9	10,8	14,5	18,2
		$L_{min} \geq$	56	71	86	120	139
		$L_{max} \leq$	261	316	396	520	654
2	Expansion sleeve	m	11,5	13,5	16,5	21,5	33,5
3	Hexagon nut	Wrench Size	13	17	19	24	30
4	Washer	$t_s \geq$	1,4	1,8	2,3	2,7	2,7
		$\varnothing d_s \geq$	15	19	23	29	36

Table A3.2: Materials

Part	Designation	Material
1	Cone bolt	Cold form steel or free cutting steel ¹⁾
2	Expansion sleeve	Stainless steel acc. to EN 10088-1:2023
3	Hexagon nut	Steel, property class 8 ¹⁾
4	Washer	Cold strip ^{1) 2)}

¹⁾ Hot-dip galvanised $\geq 50 \mu\text{m}$, according to EN ISO 10684:2004+AC:2009

²⁾ Alternative mechanical plated $\geq 53 \mu\text{m}$, according to EN ISO 12683:2004

(Fig. not to scale)

fischer Bolt Anchor hot-dip galvanised FBN II HDG

Annex A3

Appendix 6 / 13

Product description
Anchor dimensions
Materials

Specifications of intended use

fischer Bolt Anchor hot-dip galvanised FBN II HDG	M8	M10	M12	M16	M20
Static and quasi-static loads			✓		
Standard embedment depth			✓		
Reduced embedment depth			✓		
Uncracked concrete			✓		

Base materials:

- Normal weight concrete (uncracked) according to EN 206:2013+A2:2021
- Strength classes C20/25 to C50/60 according to EN 206:2013+A2:2021

Use conditions (Environmental conditions):

- Structures subject to dry internal conditions and to external atmospheric Classification of atmospheric corrosivity, determination and estimation C1 – CX according to EAD 330232-01-0601-v01

Design:

- Anchorages are to be designed under the responsibility of an engineer experienced in anchorages and concrete work
- Verifiable calculation notes and drawings are to be prepared taking account of the loads to be anchored. The position of the anchor is indicated on the design drawings (e.g. position of the anchor relative to reinforcement or to supports, etc.)
- Design of fastenings according to EN 1992-4:2018

Installation:

- Anchor installation carried out by appropriately qualified personnel and under the supervision of the person responsible for technical matters of the site
- Hammer or hollow drilling according to Annex B5

Durability:

- Variable working life according to EAD 330232-01-0601-v01

Table B1.1: Durability of hot dip galvanised **coatings** according to EN ISO 10684:2004+AC:2009 for coatings with mean thickness of minimum 50 µm

Corrosivity category	Corrosivity	Durability
		Thickness according to EN ISO 10684:2004+AC:2009 chapter 8.3 $\geq 50\mu\text{m}$ in average Durability [years]
C1	Very low	50 ¹⁾
C2	Low	50 ¹⁾
C3	Medium	25
C4	High	12,5
C5	Very high	5
CX	Extreme	2

¹⁾ Durability of coating thickness. Working life of fastener according to EAD 330232-01-0601-v01 section 1.2.2 (limited to 50 years)

fischer Bolt Anchor hot-dip galvanised FBN II HDG	Annex B1 Appendix 7 / 13
Intended use Specification	

Table B2.1 Description of typical atmospheric environments **indoor** related to the estimation of corrosivity categories according to ISO 9223:2012 Table C.1 and the corresponding durability categories according to EAD 330232-01-0601-v01 chapter 2.2.20 a (1) – (2)

Corrosivity category	Corrosivity	Typical environments – Examples	
		Indoor	EAD-330232 chapter 2.2.20 a
C1	Very low	Heated spaces with low relative humidity and insignificant pollution, e.g. offices, schools, museums	(1)
C2	Low	Unheated spaces with varying temperature and relative humidity. Low frequency of condensation and low pollution, e.g. storage, sport halls	(1)
C3	Medium	Spaces with moderate frequency of condensation and moderate pollution from production process, e.g. food-processing plants, laundries, breweries, dairies	(2)
C4	High	Spaces with high frequency of condensation and high pollution from production process, e.g. industrial processing plants, swimming pools	(2)
C5	Very high	Spaces with very high frequency of condensation and/or high pollution from production process, e.g. mines, caverns for industrial purposes, unventilated sheds in subtropical and tropical zones	(2)
CX	Extreme	Spaces with almost permanent condensation or extensive periods of exposure to extreme humidity effects and/or high pollution from production process, e.g. unventilated sheds in humid tropical zones with penetration of outdoor pollution including airborne chlorides and corrosion-stimulating particulate matter	(2)

fischer Bolt Anchor hot-dip galvanised FBN II HDG

Intended use
Specification

Annex B2

Appendix 8 / 13

Table B3.1 Description of typical atmospheric environments **outdoor** related to the estimation of corrosivity categories according to ISO 9223:2012 Table C.1 and the corresponding durability categories according to EAD 330232-01-0601-v01 chapter 2.2.20 a (1) – (2)

Corrosivity category	Corrosivity	Typical environments – Examples	
		Outdoor	EAD-330232 chapter 2.2.20 a
C1	Very low	Dry or cold zone, atmospheric environment with very low pollution and time of wetness, e.g. certain deserts, Central Arctic/Antarctica	(2)
C2	Low	Temperate zone, atmospheric environment with low pollution (SO ₂ < 5 µg/m ³), e.g. rural areas, small towns Dry or cold zone, atmospheric environment with short time of wetness, e.g. deserts, subarctic areas	(2)
C3	Medium	Temperate zone, atmospheric environment with medium pollution (SO ₂ : 5 µg/m ³ to 30 µg/m ³) or some effect of chlorides, e.g. urban areas, coastal areas with low deposition of chlorides Subtropical and tropical zone, atmosphere with low pollution	(2)
C4	High	Temperate zone, atmospheric environment with high pollution (SO ₂ : 30 µg/m ³ to 90 µg/m ³) or substantial effect of chlorides, e.g. polluted urban areas, industrial areas, coastal areas without spray of salt water or, exposure to strong effect of de-icing salts Subtropical and tropical zone, atmosphere with medium pollution	(2)
C5	Very high	Temperate and subtropical zone, atmospheric environment with very high pollution (SO ₂ : 90 µg/m ³ to 250 µg/m ³) and/or significant effect of chlorides, e.g. industrial areas, coastal areas, sheltered positions on coastline	(2)
CX	Extreme	Subtropical and tropical zone (very high time of wetness), atmospheric environment with very high SO ₂ pollution (higher than 250 µg/m ³) including accompanying and production factors and/or strong effect of chlorides, e.g. extreme industrial areas, coastal and offshore areas, occasional contact with salt spray	(2)

fischer Bolt Anchor hot-dip galvanised FBN II HDG

Annex B3

Intended use
Specification

Appendix 9 / 13

Table B4.1: Installation parameters

Size		M8	M10	M12	M16	M20
Nominal drill hole diameter	d_0	8	10	12	16	20
Maximum diameter of drill bit	$d_{cut} \leq$	8,45	10,45	12,5	16,5	20,55
Effective embedment depth	$h_{ef} \geq$ [mm]	40 (30 ¹⁾ 2 ²⁾)	50 (40 ¹⁾)	65 (50 ¹⁾)	80 (65 ¹⁾)	105 (80 ¹⁾)
Depth of drill hole to deepest point	$h_1 \geq$	56 (46 ¹⁾ 2 ²⁾)	68 (58 ¹⁾)	85 (70 ¹⁾)	104 (89 ¹⁾)	135 (110 ¹⁾)
Diameter of clearance hole in the fixture	$d_f \leq$	9	12	14	18	22
Required setting torque	T_{inst} [Nm]	15	30	40	70	200

¹⁾ Only for reduced embedment depth

²⁾ Use restricted to anchoring of structural components which are statically indeterminate

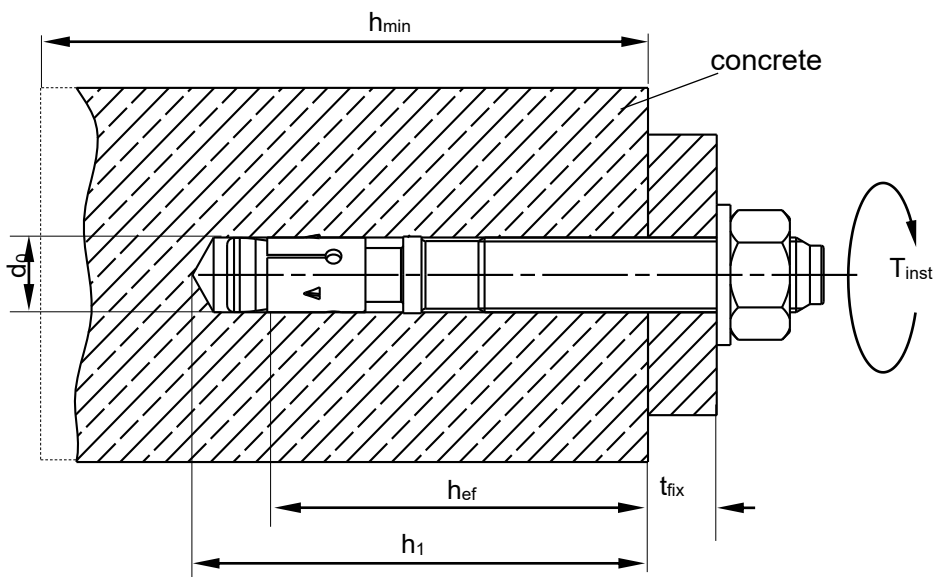

- h_{ef} = Effective embedment depth
- t_{fix} = Thickness of fixture
- h_1 = Depth of drill hole to deepest point
- h_{min} = Minimum thickness of concrete member
- T_{inst} = Required setting torque
- d_0 = Nominal drill hole diameter

(Fig. not to scale)

fischer Bolt Anchor hot-dip galvanised FBN II HDG	Annex B4
Intended use Installation parameters	Appendix 10 / 13

Table B5.1: Minimum thickness of concrete members, minimum spacing and minimum edge distance

Size		M8	M10	M12	M16	M20
Standard embedment depth	Effective embedment depth $h_{ef, sta}$	40	50	65	80	105
	Minimum thickness of member h_{min}	100	100	120	160	200
	Minimum spacing s_{min}	40	50	70	90	120
	Minimum edge distance c_{min}	40	50	70	90	120
Reduced embedment depth	Effective embedment depth $h_{ef, red}$	30 ¹⁾	40	50	65	80
	Minimum thickness of member h_{min}	100	100	100	120	160
	Minimum spacing s_{min}	40	50	70	90	120
	Minimum edge distance c_{min}	40	80	100	120	120

¹⁾ Use restricted to anchoring of structural components which are statically indeterminate

Installation instructions

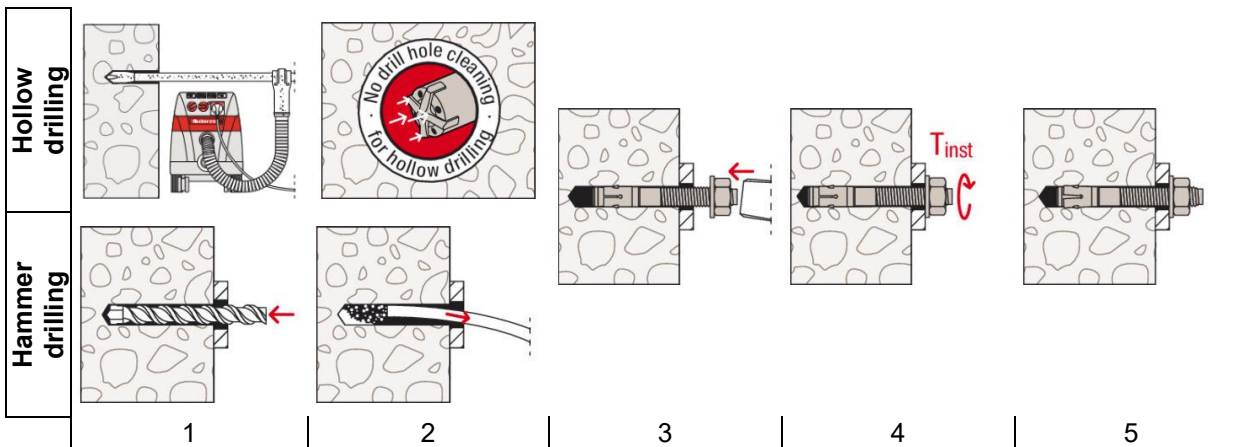

No.	Description	
1	Create drill hole with hammer drill	Create drill hole with hollow drill and vacuum cleaner
2	Clean bore hole	-
3	Set anchor	
4	Expand anchor with prescribed installation torque T_{inst}	
5	Finished installation	

Types of drills	
Hammer drill	
Hollow drill	

(Fig. not to scale)

fischer Bolt Anchor hot-dip galvanised FBN II HDG	Annex B5 Appendix 11 / 13
Intended use Minimum thickness of member, minimum spacing and edge distance Installation instructions	

Table C1.1: Characteristic values of **tension** resistance for **standard and reduced embedment depth** under static and quasi-static loads

Size			M8	M10	M12	M16	M20
Steel failure for standard and reduced embedment depth							
Characteristic resistance	$N_{Rk,s}$	[kN]	16,5	27,2	41,6	77,9	107
Partial safety factor	γ_{Ms}	[-]	1,4	1,4	1,4	1,5	1,5
Pullout failure for standard embedment depth							
Characteristic resistance C20/25	$N_{Rk,p}$	[kN]	- ¹⁾				
Pullout failure for reduced embedment depth							
Characteristic resistance C20/25	$N_{Rk,p}$	[kN]	6 ²⁾	- ¹⁾			
Increasing factors for $N_{Rk,p}$	ψ_c	C25/30	1,12				
		C30/37	1,23				
		C35/45	1,32				
		C40/50	1,41				
		C45/55	1,50				
		C50/60	1,58				
Installation safety factor	γ_{inst}	[-]	1,0				
Concrete cone and splitting failure for standard and reduced embedment depth							
Effective embedment depth	$\frac{h_{ef, sta}}{h_{ef, red}}$	[mm]	40	50	65	80	105
			30 ²⁾	40	50	65	80
Factor k_1 for uncracked concrete	$k_{ucr,N}$	[-]	11,0				
Spacing	$s_{cr,N}$	[mm]	3 h_{ef}				
Edge distance	$c_{cr,N}$	[mm]	1,5 h_{ef}				
Spacing (splitting failure)	$s_{cr,sp}$	[mm]	190	200	290	350	370
Edge distance (splitting failure)	$c_{cr,sp}$	[mm]	95	100	145	175	185

¹⁾ Pullout failure is not relevant

²⁾ Use restricted to anchoring of structural components which are statically indeterminate

fischer Bolt Anchor hot-dip galvanised FBN II HDG

Annex C1

Performances
Characteristic values of tension resistance for standard and reduced embedment

Appendix 12 / 13

Table C2.1: Characteristic values of **shear** resistance for **standard and reduced embedment depth** under static and quasi-static loads

Size		M8	M10	M12	M16	M20
Steel failure without lever arm for standard and reduced embedment depth						
Characteristic resistance	$V_{RK,s}^0$ [kN]	13,3	21,0	31,3	55,1	67
Steel failure with lever arm for standard embedment depth						
Characteristic bending moment	$M_{RK,s}^0$ [Nm]	26,2	52,3	91,6	232,2	422
Steel failure with lever arm for reduced embedment depth						
Characteristic bending moment	$M_{RK,s}^0$ [Nm]	19,9 ¹⁾	45,9	90,0	226,9	349
Concrete pryout failure for standard and reduced embedment depth						
Factor for pryout	k_8	1,8	2,1	2,3	2,3	2,3
Installation safety factor	γ_{inst} [-]	1,0				
Concrete edge failure for standard and reduced embedment depth						
Effective length of anchor	$l_{f,sta}$	40	50	65	80	105
	$l_{f,red}$ [mm]	30 ¹⁾	40	50	65	80
Effective diameter of anchor	d_{nom}	8	10	12	16	20
Installation safety factor	γ_{inst} [-]	1,0				

¹⁾ Use restricted to anchoring of structural components which are statically indeterminate

Table C2.2: Displacements due to tension loads

Size		M8	M10	M12	M16	M20
Standard embedment depth	$h_{ef, sta}$ [mm]	40	50	65	80	105
Tension load C20/25	N [kN]	6,1	8,5	12,6	17,2	25,8
Displacements	$\frac{\delta_{N0}}{\delta_{N\infty}}$ [mm]	0,6	0,9	1,5	1,8	1,8
		3,1				
Reduced embedment depth	$h_{ef, red}$ [mm]	30	40	50	65	80
Tension load C20/25	N [kN]	2,8	6,1	8,5	12,6	17,2
Displacements	$\frac{\delta_{N0}}{\delta_{N\infty}}$ [mm]	0,4	0,7	0,7	0,9	1,0
		1,6				

Table C2.3: Displacements due to shear loads

Size		M8	M10	M12	M16	M20
Shear load	V [kN]	7,6	12,0	17,9	31,5	38,2
Displacements	$\frac{\delta_{V0}}{\delta_{V\infty}}$ [mm]	1,5	1,6	2,0	3,0	2,6
		2,3	2,4	3,0	4,5	3,9

fischer Bolt Anchor hot-dip galvanised FBN II HDG

Annex C2

Performances

Characteristic values of shear resistance for standard and reduced embedment depth
Displacements