

YDEEVNEDEKLARATION

DoP 0191

til fischer injektionsmørtel Superbond (Flydende fastgørelse til brug i beton)

DA

1. <u>Varetypens unikke identifikationskode:</u>	DoP 0191		
2. <u>Anvendelsesformål:</u>	Eftermonteret befæstelse i revnet eller ikke-revnet beton. Se appendiks, specifikt bilagene B1- B15		
3. <u>Fabrikant:</u>	fischerwerke GmbH & Co. KG, Otto-Hahn-Straße 15, 79211 Denzlingen, Tyskland		
4. <u>Bemyndiget repræsentant:</u>	-		
5. <u>System(er) til vurdering og kontrol af konstanten af ydeevnen:</u>	1		
6. <u>Europæisk vurderingsdokument:</u>	EAD 330499-01-0601		
Europæisk Teknisk Vurdering	ETA-12/0258; 2020-06-17		
Teknisk vurderingsorgan:	DIBt- Deutsches Institut für Bautechnik		
Notificeret organ(er)	1343 MPA Darmstadt / 2873 TU Darmstadt		
7. <u>Deklareret ydeevne(r):</u>	Mekanisk modstand og stabilitet (BWR 1)		
Karakteristisk modstand for træklaster (statisk og quasi-statisk belastning):	Modstand overfor stålsvig: Modstand overfor kombineret udtræk og beton-kegle brud: Modstand overfor svigt af beton-kegle: Kantafstand til forhindring af flækning under belastning: Robusthed: Maksimal kærv ved montering: Min. kant og indbyrdes afstand:	Bilagen C1- C3 Bilagen C4- C10 Bilagen C4 Bilagen C4 Bilagen C4-C10, C15, C16 Bilagen B4- B8 Bilagen B4- B8	$\tau_{Rk,100} =$ NPD
Karakteristisk modstand for tværlast (statisk og quasi-statisk belastning):	Modstand overfor stålsvig: Modstand overfor svigt ved udtrækning: Modstand overfor svigt af betonkant:	Bilagen C1- C3 Bilagen C4 Bilagen C4	
Karakteristisk modstand og Forskydninger for seismiske ydelseskategorier C1 og C2:	Modstand overfor spændingslast, forskydninger, kategori C1: Modstand overfor spændingslast, forskydninger, kategori C2: Modstand overfor tværlast, forskydninger, kategori C1: Modstand overfor tværlast, forskydninger, kategori C2: Faktor ringhul:	Bilagen C13, C14, C15 Bilagen C13, C14, C16 Bilagen C13, C14 Bilagen C13, C14, C16 Bilagen C13	
Forskydninger under kortvarig og langvarig belastning:	Forskydninger under kortvarig og langvarig belastning:	Bilagen C11- C12	
Hygiene, sundhed og miljø (BWR 3)	NPA		
Indhold, emission og / eller udledning af farlige stoffer:			



8. Relevant teknisk dokumentation og/eller specifik teknisk dokumentation: -

Ydeevnen for den vare, der er anført ovenfor, er i overensstemmelse med den deklarerede ydeevne. Denne ydeevnedeklaration er udarbejdet i overensstemmelse med forordning (EU) nr. 305/2011 på eneansvar af den fabrikant, der er anført ovenfor.

Underskrevet for fabrikanten og på dennes vegne af:

Thilo Pregartner, Dr.-Ing.
Tumlingen, 2020-07-01

Peter Schillinger, Dipl.-Ing.

Denne DoP er tilgængelig i forskellige sprogversioner. I tilfælde af fortolkningsmæssig uoverensstemmelse, henvises der til den engelske version, som altid er gældende.

Appendikset indeholder frivillige og udvidede informationer på engelsk. Disse overgår de lokale (sprogneutrale) retslige krav.

Specific Part

1 Technical description of the product

The injection system fischer Superbond is a bonded anchor for use in concrete consisting of a cartridge with injection mortar fischer FIS SB or a resin capsule fischer RSB and a steel element according to Annex A 5.

The steel element is placed into a drilled hole filled with injection mortar and is anchored via the bond between metal part, injection mortar and concrete.

The resin capsule is placed into the hole and the steel element is driven by machine with simultaneous hammering and turning. The anchor rod is anchored via the bond between steel element, chemical mortar and concrete

The product description is given in Annex A.

2 Specification of the intended use in accordance with the applicable European Assessment Document

The performances given in Section 3 are only valid if the anchor is used in compliance with the specifications and conditions given in Annex B.

The verifications and assessment methods on which this European Technical Assessment is based lead to the assumption of a working life of the anchor of at least 50 years. The indications given on the working life cannot be interpreted as a guarantee given by the producer, but are to be regarded only as a means for choosing the right products in relation to the expected economically reasonable working life of the works.

3 Performance of the product and references to the methods used for its assessment

3.1 Mechanical resistance and stability (BWR 1)

Essential characteristic	Performance
Characteristic resistance to tension load (static and quasi-static loading)	See Annex B 4 to B 8, C 1 to C 10
Characteristic resistance to shear load (static and quasi-static loading)	See Annex C 1 to C 4
Displacements under short-term and long-term loading	See Annex C 11 and C 12
Characteristic resistance and displacements for seismic performance categories C1 and C2	See Annex C 13 to C 16

3.2 Hygiene, health and the environment (BWR 3)

Essential characteristic	Performance
Content, emission and/or release of dangerous substances	No performance assessed

4 Assessment and verification of constancy of performance (AVCP) system applied, with reference to its legal base

In accordance with the European Assessment Document EAD 330499-01-0601 the applicable European legal act is: [96/582/EC].

The system to be applied is: 1

Installation conditions part 1

anchor rod or fischer anchor rod RG M with fischer injection system FIS SB

Pre-positioned installation

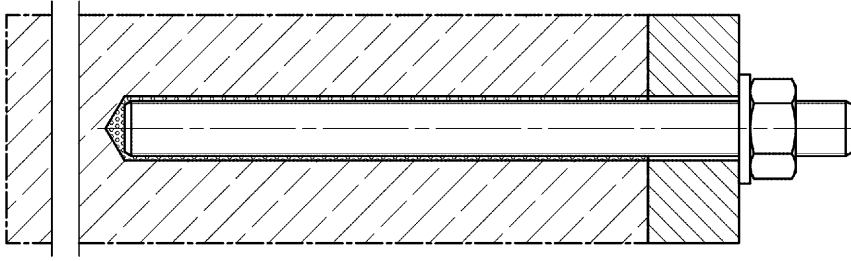

Push through installation (annular gap filled with mortar)

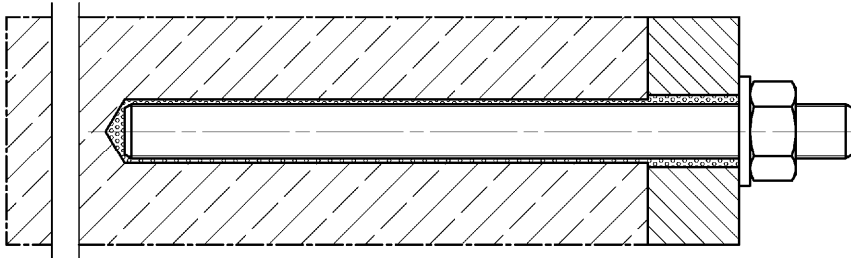

Pre-positioned or push through installation with subsequently injected fischer filling disc
(annular gap filled with mortar)

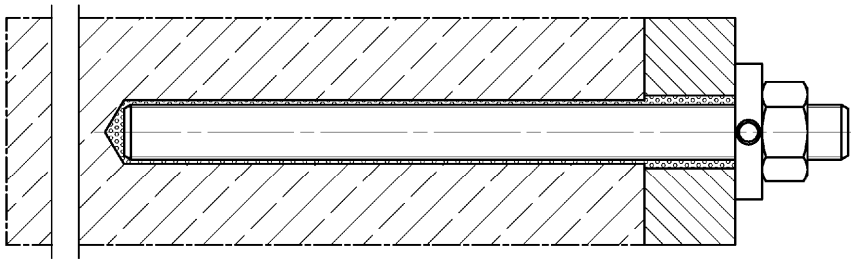

Figures not to scale

fischer Superbond

Product description
Installation conditions part 1

Annex A 1

Appendix 3/ 40

Installation conditions part 2

Reinforcing bar with fischer injection system FIS SB

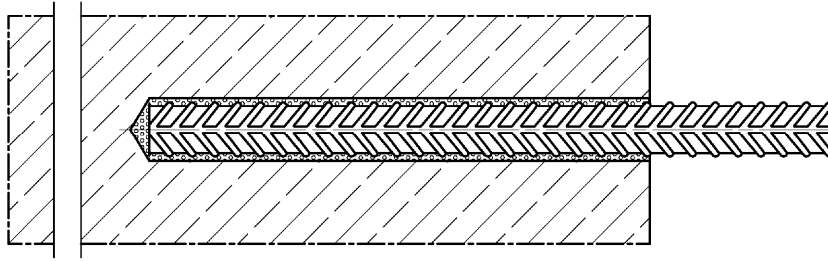

fischer rebar anchor FRA with fischer injection system FIS SB

Pre-positioned installation

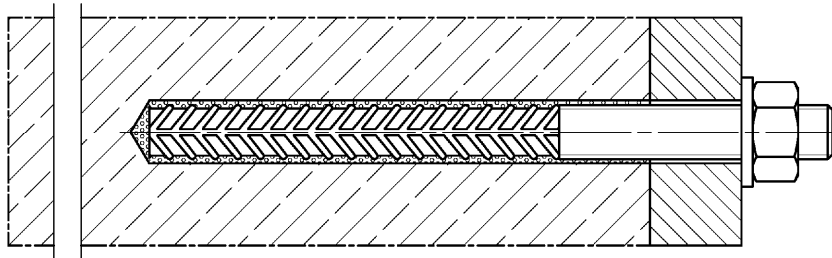

Push through installation (annular gap filled with mortar)

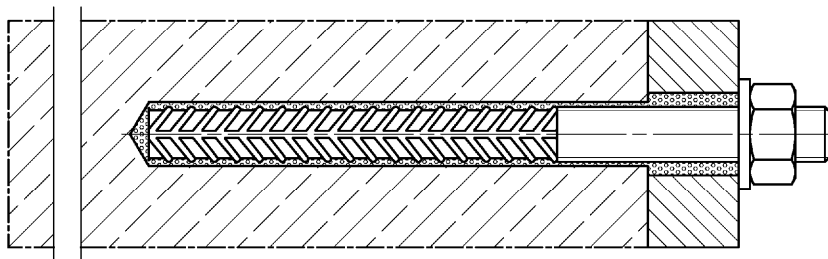

Figures not to scale

fischer Superbond

Product description
Installation conditions part 2

Annex A 2

Appendix 4/ 40

Installation conditions part 3

fischer internal threaded anchor RG MI with fischer resin capsule system RSB or fischer injection system FIS SB

Pre-positioned installation

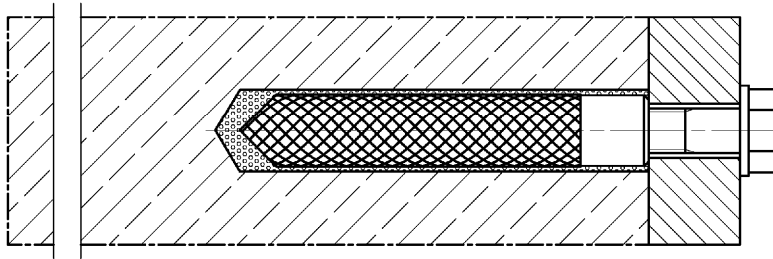

Pre-positioned installation with subsequently injected fischer filling disc (annular gap filled with mortar)

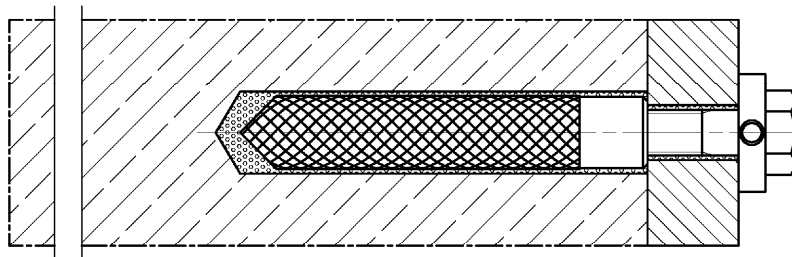

fischer anchor rod RG M with fischer resin capsule system RSB

Pre-positioned installation

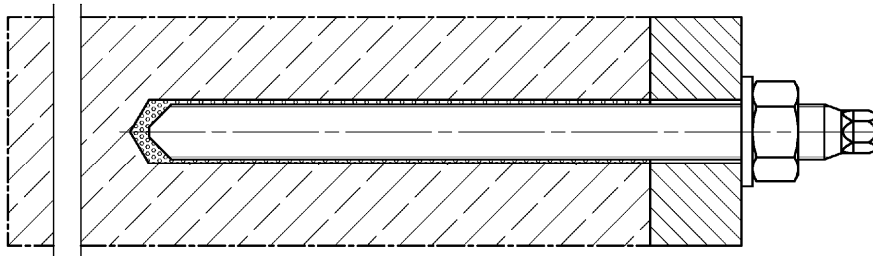

Pre-positioned installation with subsequently injected fischer filling disc (annular gap filled with mortar)

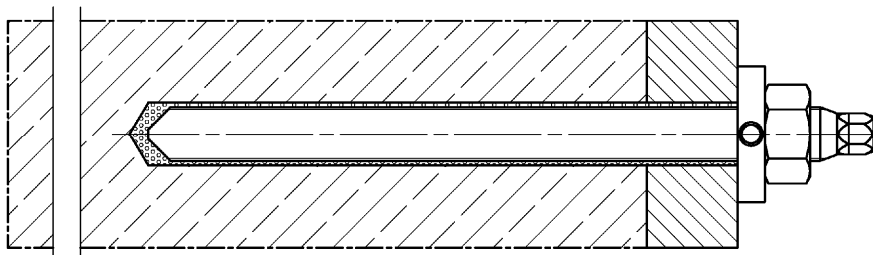

Figures not to scale

fischer Superbond

Product description
Installation conditions part 3

Annex A 3

Appendix 5/ 40

Overview system components Part 1

Mortar cartridge (shuttle cartridge) with sealing cap; Sizes: 390 ml, 585 ml, 1100 ml, 1500 ml

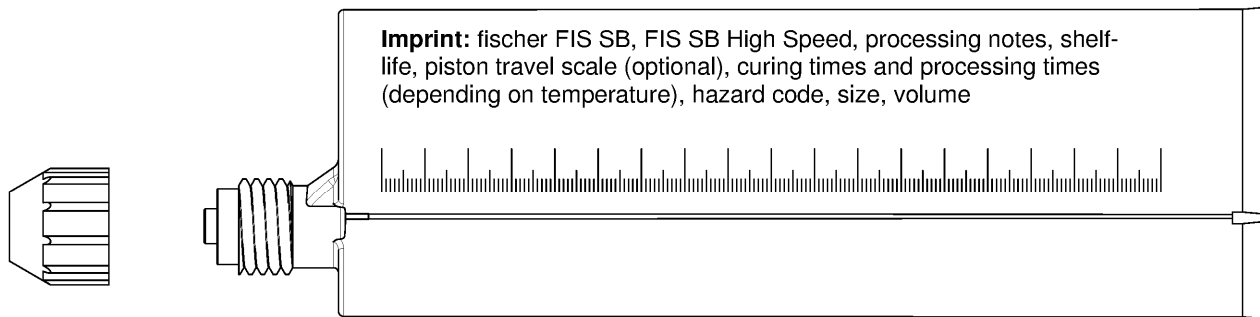

Resin capsule

Sizes: 8, 10 mini, 10, 12 mini, 12, 16 mini, 16, 16 E, 20, 20 E / 24, 30



Static mixer FIS MR Plus or UMR

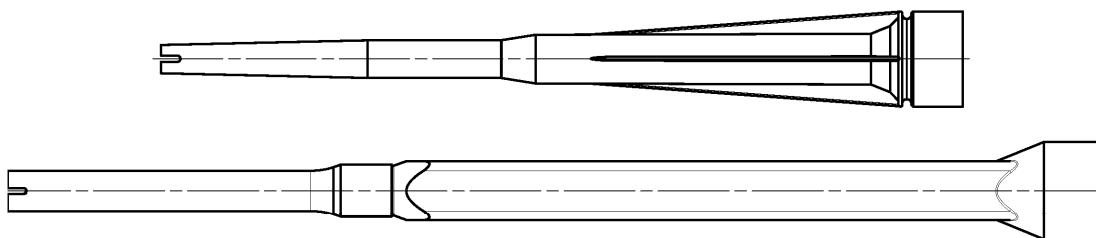

Injection adapter / extension tube for static mixer

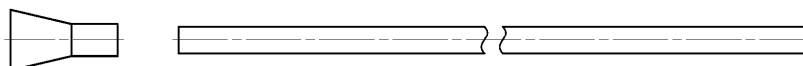

Figures not to scale

fischer Superbond

Product description

Overview system components part 1;
cartridges / capsule / static mixer / injection adapter

Annex A 4

Appendix 6/ 40

Overview system components Part 2

anchor rod

Sizes: M8, M10, M12, M16, M20, M24, M27, M30

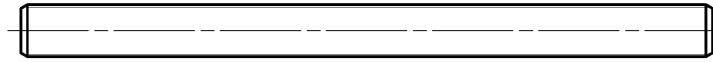

fischer anchor rod RG M

Sizes: M8, M10, M12, M16, M20, M24, M30

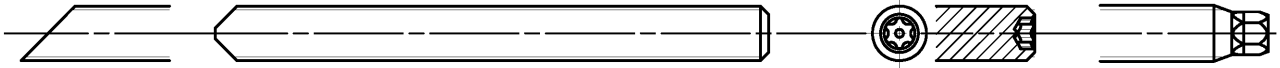

fischer internal threaded anchor RG MI

Size: M8, M10, M12, M16, M20

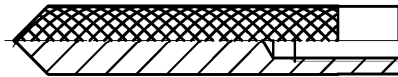

Screw / threaded rod / washer / hexagon nut

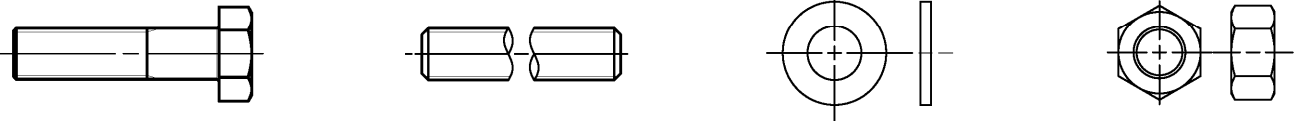

fischer filling disc with injection adapter

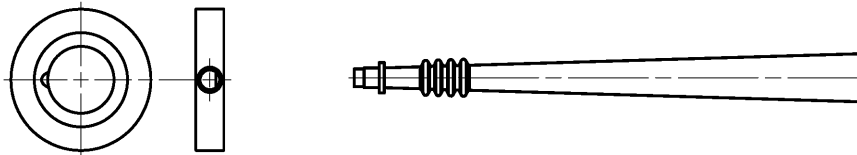

Reinforcing bar

Nominal diameters: $\phi 8$, $\phi 10$, $\phi 12$, $\phi 14$, $\phi 16$, $\phi 20$, $\phi 25$, $\phi 28$, $\phi 32$



fischer rebar anchor FRA

Sizes: M12, M16, M20, M24



Figures not to scale

fischer Superbond

Product description

Overview system components part 2;
steel components

Annex A 5

Appendix 7 / 40

Overview system components Part 3

Cleaning brush BS / BSB



Blow-out pump ABG or ABP with cleaning nozzle



Figures not to scale

fischer Superbond

Product description

Overview system components part 3;
cleaning brush / blow-out pump / injection adapter

Annex A 6

Appendix 8/ 40

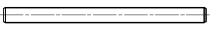





Table A7.1: Materials

Part	Designation	Material		
1	Injection cartridge	Mortar, hardener, filler		
	Steel grade	Steel	Stainless steel R	High corrosion resistant steel HCR ²⁾
		zinc plated	acc. to EN 10088-1:2014 Corrosion resistance class CRC III acc. to EN 1993-1-4:2015	acc. to EN 10088-1:2014 Corrosion resistance class CRC V acc. to EN 1993-1-4:2015
2	Anchor rod	Property class 4.8, 5.8 or 8.8; EN ISO 898-1:2013 zinc plated $\geq 5 \mu\text{m}$, ISO 4042:2018/Zn5/An(A2K) or hot dip galvanised $\geq 40 \mu\text{m}$ EN ISO 10684:2004 $f_{uk} \leq 1000 \text{ N/mm}^2$ $A_5 > 12\%$ fracture elongation	Property class 50, 70 or 80 EN ISO 3506-1:2009 1.4401; 1.4404; 1.4578; 1.4571; 1.4439; 1.4362; 1.4062, 1.4662, 1.4462; EN 10088-1:2014 $f_{uk} \leq 1000 \text{ N/mm}^2$ $A_5 > 12\%$ fracture elongation	Property class 50 or 80 EN ISO 3506-1:2009 or property class 70 with $f_{yk} = 560 \text{ N/mm}^2$ 1.4565; 1.4529; EN 10088-1:2014 $f_{uk} \leq 1000 \text{ N/mm}^2$ $A_5 > 12\%$ fracture elongation
Fracture elongation $A_5 > 8\%$, for applications without requirements for seismic performance category C2				
3	Washer ISO 7089:2000	zinc plated $\geq 5 \mu\text{m}$, ISO 4042:2018/Zn5/An(A2K) or hot dip galvanised $\geq 40 \mu\text{m}$ EN ISO 10684:2004	1.4401; 1.4404; 1.4578; 1.4571; 1.4439; 1.4362; EN 10088-1:2014	1.4565; 1.4529; EN 10088-1:2014
4	Hexagon nut	Property class 5 or 8; EN ISO 898-2:2012 zinc plated $\geq 5 \mu\text{m}$, ISO 4042:2018/Zn5/An(A2K) or hot dip galvanised $\geq 40 \mu\text{m}$ EN ISO 10684:2004	Property class 50, 70 or 80 EN ISO 3506-1:2009 1.4401; 1.4404; 1.4578; 1.4571; 1.4439; 1.4362; EN 10088-1:2014	Property class 50, 70 or 80 EN ISO 3506-1:2009 1.4565; 1.4529 EN 10088-1:2014
5	fischer internal threaded anchor RG MI	Property class 5.8 ISO 898-1:2013 zinc plated $\geq 5 \mu\text{m}$, ISO 4042:2018/Zn5/An(A2K)	Property class 70 EN ISO 3506-1:2009 1.4401; 1.4404; 1.4578; 1.4571; 1.4439; 1.4362; EN 10088-1:2014	Property class 70 EN ISO 3506-1:2009 1.4565; 1.4529; EN 10088-1:2014
6	Commercial standard screw or threaded rod for fischer internal threaded anchor RG MI	Property class 5.8 or 8.8; EN ISO 898-1:2013 zinc plated $\geq 5 \mu\text{m}$, ISO 4042:2018/Zn5/An(A2K), $A_5 > 8\%$ fracture elongation	Property class 70 EN ISO 3506-1:2009 1.4401; 1.4404; 1.4578; 1.4571; 1.4439; 1.4362; EN 10088-1:2014 $A_5 > 8\%$ fracture elongation	Property class 70 EN ISO 3506-1:2009 1.4565; 1.4529; EN 10088-1:2014 $A_5 > 8\%$ fracture elongation
7	fischer filling disc similar to DIN 6319-G	zinc plated $\geq 5 \mu\text{m}$, ISO 4042:2018/Zn5/An(A2K) or hot dip galvanised $\geq 40 \mu\text{m}$ EN ISO 10684:2004	1.4401; 1.4404; 1.4578; 1.4571; 1.4439; 1.4362; EN 10088-1:2014	1.4565; 1.4529; EN 10088-1:2014
8	Reinforcing bar EN 1992-1-1:2004 and AC:2010, Annex C	Bars and de-coiled rods, class B or C with f_{yk} and k according to NDP or NCL according to EN 1992-1-1/NA $f_{uk} = f_{tk} = k \cdot f_{yk}$		
9	fischer rebar anchor FRA	Rebar part: Bars and de-coiled rods class B or C with f_{yk} and k according to NDP or NCL of EN 1992-1-1:2004+AC:2010 $f_{uk} = f_{tk} = k \cdot f_{yk}$	Threaded part: Property class 70 or 80 EN ISO 3506-1:2009 1.4401, 1.4404, 1.4571, 1.4578, 1.4439, 1.4362, 1.4062 acc. to EN 10088-1:2014 Corrosion resistance class CRC III acc. to EN 1993-1-4:2015 1.4565; 1.4529 acc. to EN 10088-1:2014 Corrosion resistance class CRC V acc. to EN 1993-1-4:2015	

fischer Superbond	Annex A 7 Appendix 9/ 40
Product description Materials	

Specifications of intended use (part 1)

Table B1.1: Overview use and performance categories, **injection mortar system FIS SB**

Anchorages subject to		FIS SB with ...							
		anchor rod 	fischer internal threaded anchor RG MI 	Reinforcing bar 	fischer rebar anchor FRA 				
Hammer drilling with standard drill bit 		all sizes							
Hammer drilling with hollow drill bit (fischer "FHD", Heller "Duster Expert"; Bosch „Speed Clean“; Hilti "TE-CD, TE-YD", DreBo „D-Plus“, DreBo „D-Max“) 		Nominal drill bit diameter (d ₀) 12 mm to 35 mm							
Diamond drilling 		not permitted							
Static and quasi static load, in	uncracked concrete	all sizes	Tables: C1.1 C4.1 C5.1 C11.1	all sizes	Tables: C2.1 C4.1 C7.1 C11.2	all sizes	Tables: C3.1 C4.1 C9.1 C12.1	all sizes	Tables: C3.2 C4.1 C10.1 C12.2
	cracked concrete								
Seismic performance category (only hammer drilling with standard / hollow drill bits)	C1	all sizes	Tables: C13.1 C14.2 C15.1	_1)	all sizes	Tables: C14.1 C14.2 C15.2	_1)	_1)	_1)
	C2	M12 M16 M20 M24	Tables: C13.1 C14.2 C16.1			_1)			
Use category	I1 dry or wet concrete	all sizes							
	I2 water filled hole	not permitted							
Installation direction	D3 (downward and horizontal and upwards (overhead) installation)								
Installation method	pre-positioned or push through installation								
Installation temperature	FIS SB: T _{i,min} = -15 °C to T _{i,max} = +40 °C FIS SB High Speed: T _{i,min} = -20 °C to T _{i,max} = +40 °C								
In-service temperature	Temperature range I	-40 °C to +40 °C		T _{st} = +40 °C / T _{lt} = +24 °C					
	Temperature range II	-40 °C to +80 °C		T _{st} = +80 °C / T _{lt} = +50 °C					
	Temperature range III	-40 °C to +120 °C		T _{st} = +120 °C / T _{lt} = +72 °C					
	Temperature range IV	-40 °C to +150 °C		T _{st} = +150 °C / T _{lt} = +90 °C					

¹⁾ No performance assessed

fischer Superbond





Intended use
Specifications (part 1), fischer injection mortar system FIS SB

Annex B 1

Appendix 10/ 40

Specifications of intended use (part 2)

Table B2.1: Overview use and performance categories, **resin capsule system RSB**

Anchorages subject to		RSB with ...			
		fischer anchor rod RG M 	fischer internal threaded anchor RG MI 		
Hammer drilling with standard drill bit 		all sizes			
Hammer drilling with hollow drill bit (fischer "FHD", Heller "Duster Expert"; Bosch "Speed Clean"; Hilti "TE-CD, TE-YD", DreBo "D-Plus", DreBo "D-Max") 		Nominal drill bit diameter (d_0) 12 mm to 35 mm	all sizes		
Diamond drilling 		all sizes ¹⁾			
Static and quasi static load, in	uncracked concrete	all sizes	Tables: C1.1 C4.1 C6.1 C11.1	all sizes	Tables: C2.1 C4.1 C8.1 C11.2
	cracked concrete	all sizes ¹⁾		all sizes ¹⁾	
Seismic performance category (only hammer drilling with standard / hollow drill bits)	C1	all sizes	Tables: C13.1 C14.2 C15.1	_2)	
	C2	_2)			
Use category	I1 dry or wet concrete	all sizes			
	I2 water filled hole	all sizes			
Installation direction	D3 (downward and horizontal and upwards (overhead) installation)				
Installation method	only pre-positioned installation				
Installation temperature	$T_{i,min} = -30\text{ °C}$ to $T_{i,max} = +40\text{ °C}$				
In-service temperature	Temperature range I	-40 °C to +40 °C	$T_{st} = +40\text{ °C}$ / $T_{lt} = +24\text{ °C}$		
	Temperature range II	-40 °C to +80 °C	$T_{st} = +80\text{ °C}$ / $T_{lt} = +50\text{ °C}$		
	Temperature range III	-40 °C to +120 °C	$T_{st} = +120\text{ °C}$ / $T_{lt} = +72\text{ °C}$		
	Temperature range IV	-40 °C to +150 °C	$T_{st} = +150\text{ °C}$ / $T_{lt} = +90\text{ °C}$		

¹⁾ For diamond drilling in cracked concrete only nominal drill bit diameters (d_0) ≥ 18 mm are permitted

²⁾ No performance assessed

fischer Superbond

Intended use
Specifications (part 2), fischer resin capsule system RSB

Annex B 2

Appendix 11/ 40

Specifications of intended use (part 3)

Base materials:

- Compacted reinforced or unreinforced normal weight concrete without fibres of strength classes C20/25 to C50/60 according to EN 206:2013+A1:2016

Use conditions (Environmental conditions):

- Structures subject to dry internal conditions (zinc coated steel, stainless steel or high corrosion resistant steel).
- For all other conditions according to EN1993-1-4:2015 corresponding to corrosion resistance classes to Annex A 7 table A7.1.

Design:

- Anchorages have to be designed by a responsible engineer with experience of concrete anchor design.
- Verifiable calculation notes and drawings are to be prepared taking account of the loads to be anchored. The position of the anchor is indicated on the design drawings (e. g. position of the anchor relative to reinforcement or to supports, etc.).
- Anchorages are designed in accordance with: EN 1992-4:2018 and EOTA Technical Report TR 055, Edition February 2018.

Installation:

- Anchor installation is to be carried out by appropriately qualified personnel and under the supervision of the person responsible for technical matters of the site
- In case of aborted hole: The hole shall be filled with mortar
- Anchorage depth should be marked and adhered to on installation
- Overhead installation is allowed

fischer Superbond

Intended use
Specifications (part 3)

Annex B 3

Appendix 12/ 40

Table B4.1: Installation parameters for anchor rods in combination with injection mortar system FIS SB

Anchor rods		Thread	M8	M10	M12	M16	M20	M24	M27	M30	
Width across flats	SW	[mm]	13	17	19	24	30	36	41	46	
Nominal drill hole diameter	d_0		10	12	14	18	24	28	30	35	
Drill hole depth	h_0		$h_0 = h_{ef}$								
Effective embedment depth	$h_{ef, min}$		60	60	70	80	90	96	108	120	
	$h_{ef, max}$		160	200	240	320	400	480	540	600	
Minimum spacing and minimum edge distance	s_{min} =		40	45	55	65	85	105	120	140	
	c_{min}										
Diameter of the clearance hole of the fixture	pre-positioned installation d_f		9	12	14	18	22	26	30	33	
	push through installation d_f		11	14	16	20	26	30	33	40	
Min. thickness of concrete member	h_{min}		$h_{ef} + 30$ (≥ 100)				$h_{ef} + 2d_0$				
Maximum setting torque	$\max T_{inst}$	[Nm]	10	20	40	60	120	150	200	300	

fischer anchor rod



Marking (on random place) fischer anchor rod:

Steel zinc plated PC ¹⁾ 8.8	• or +	Steel hot-dip PC ¹⁾ 8.8	•
High corrosion resistant steel HCR PC ¹⁾ 50	•	High corrosion resistant steel HCR PC ¹⁾ 70	-
High corrosion resistant steel HCR PC ¹⁾ 80	(Stainless steel R property class 50	~
Stainless steel R property class 80	*		

Alternatively: Colour coding according to DIN 976-1:2016 ¹⁾ PC = property class

Installation conditions:

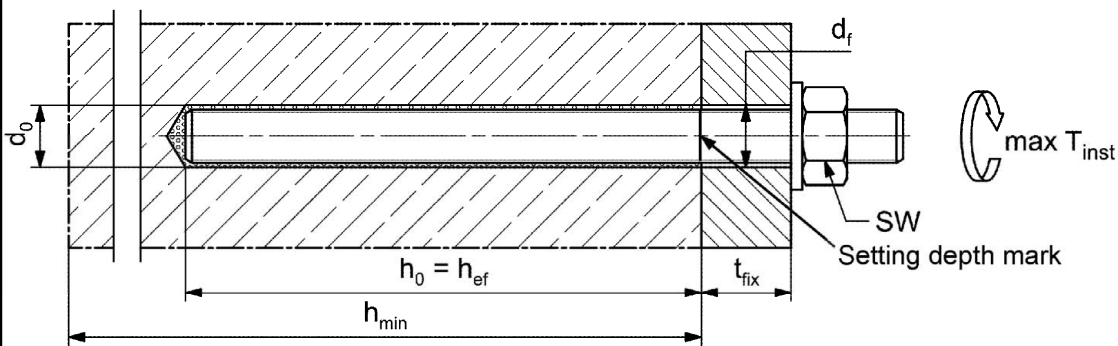

Commercial standard threaded rods, washers and hexagon nuts may also be used if the following requirements are fulfilled:

- Materials, dimensions and mechanical properties according to Annex A 7, Table A7.1
- Inspection certificate 3.1 according to EN 10204:2004, the documents have to be stored
- Setting depth is marked

Figures not to scale

fischer Superbond

Intended use

Installation parameters for anchor rods in combination with injection mortar system FIS SB

Annex B 4

Appendix 13/ 40

Table B5.1: Installation parameters for fischer anchor rods RG M in combination with resin capsule system RSB

Anchor rod RG M		Thread	M8	M10	M12	M16	M20	M24	M30	
Width across flats	SW	[mm]	13	17	19	24	30	36	46	
Nominal drill hole diameter	d_0		10	12	14	18	25	28	35	
Drill hole depth	h_0		$h_0 = h_{ef}$							
Effective embedment depth	$h_{ef,1}$		---	75	75	95	---	---	---	
	$h_{ef,2}$		80	90	110	125	170	210	280	
	$h_{ef,3}$		---	150	150	190	210	---	---	
Minimum spacing and minimum edge distance	$s_{min} = c_{min}$		40	45	55	65	85	105	140	
Diameter of the pre-positioned clearance hole of the fixture installation	d_f		9	12	14	18	22	26	33	
Min. thickness of concrete member	h_{min}		$h_{ef} + 30$ (≥ 100)			$h_{ef} + 2d_0$				
Maximum setting torque	$\max T_{inst}$		[Nm]	10	20	40	60	120	150	300

fischer anchor rod RG M

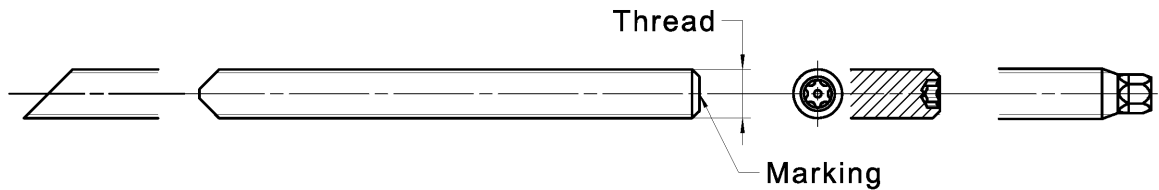

Marking (on random place) fischer anchor rod RG M:

Steel zinc plated PC ¹⁾ 8.8	• or +	Steel hot-dip PC ¹⁾ 8.8	•
High corrosion resistant steel HCR PC ¹⁾ 50	•	High corrosion resistant steel HCR PC ¹⁾ 70	-
High corrosion resistant steel HCR PC ¹⁾ 80	(Stainless steel R property class 50	~
Stainless steel R property class 80	*		
Alternatively: Colour coding according to DIN 976-1:2016			¹⁾ PC = property class

Installation conditions:

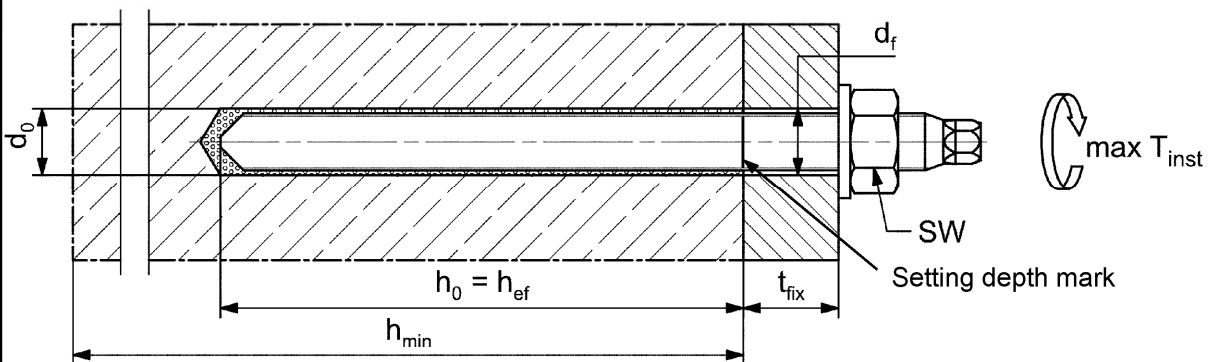

Figures not to scale

fischer Superbond

Intended use

Installation parameters for fischer anchor rods RG M in combination with resin capsule system RSB

Annex B 5

Appendix 14/ 40

Table B6.1: Installation parameters for **fischer internal threaded anchors RG MI**

Internal threaded anchor RG MI		Thread	M8	M10	M12	M16	M20
Sleeve diameter	$d = d_H$	[mm]	12	16	18	22	28
Nominal drill hole diameter	d_0		14	18	20	24	32
Drill hole depth	h_0		$h_0 = h_{ef} = L_H$				
Effective embedment depth ($h_{ef} = L_H$)	h_{ef}		90	90	125	160	200
Minimum spacing and minimum edge distance	s_{min} = c_{min}		55	65	75	95	125
Diameter of clearance hole in the fixture	d_f		9	12	14	18	22
Minimum thickness of concrete member	h_{min}		120	125	165	205	260
Maximum screw-in depth	$l_{E,max}$		18	23	26	35	45
Minimum screw-in depth	$l_{E,min}$		8	10	12	16	20
Maximum installation torque	$\max T_{inst}$		[Nm]	10	20	40	80

fischer internal threaded anchor RG MI

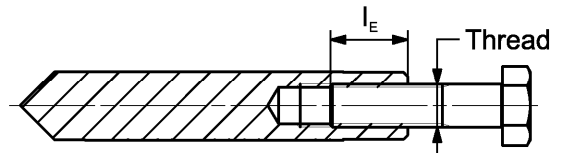
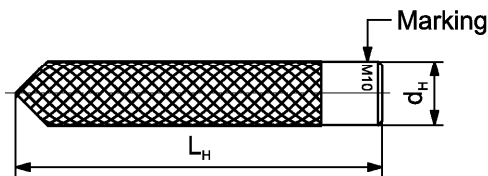

Marking: Anchor size e. g.: **M10**
 Stainless steel → additional R; e.g.: **M10 R**
 High corrosion resistant steel R → additional C; e.g.: **M10 HCR**

Retaining bolt or threaded rods (including nut and washer) must comply with the appropriate material and strength class of Annex A 7, Table A7.1

Installation conditions:

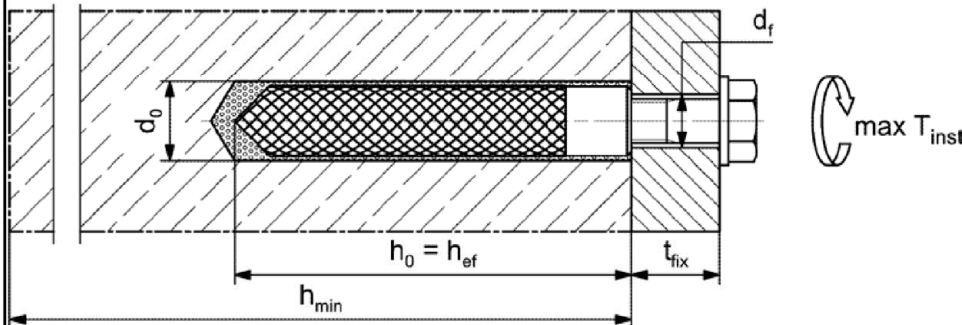

Figures not to scale

fischer Superbond

Intended use
 Installation parameters for fischer internal threaded anchors RG MI

Annex B 6

Appendix 15/ 40

Table B7.1: Installation parameters for reinforcing bars

Nominal diameter of the bar		ϕ	8 ¹⁾	10 ¹⁾	12 ¹⁾	14	16	20	25	28	32			
Nominal drill hole diameter	d_0	[mm]	10	12	12	14	14	16	18	20	25	30	35	40
Drill hole depth	h_0		$h_0 = h_{ef}$											
Effective embedment depth	$h_{ef,min}$		60	60	70	75	80	90	100	112	128			
	$h_{ef,max}$		160	200	240	280	320	400	500	560	640			
Minimum spacing and minimum edge distance	s_{min} = c_{min}		40	45	55	60	65	85	110	130	160			
Minimum thickness of concrete member	h_{min}	$h_{ef} + 30$ (≥ 100)				$h_{ef} + 2d_0$								

¹⁾ Both drill hole diameters can be used

Reinforcing bar



- The minimum value of related rib area $f_{R,min}$ must fulfil the requirements of EN 1992-1-1:2004+AC:2010
- The rib height must be within the range: $0,05 \cdot \phi \leq h_{rib} \leq 0,07 \cdot \phi$
(ϕ = Nominal diameter of the bar, h_{rib} = rib height)

Installation conditions:

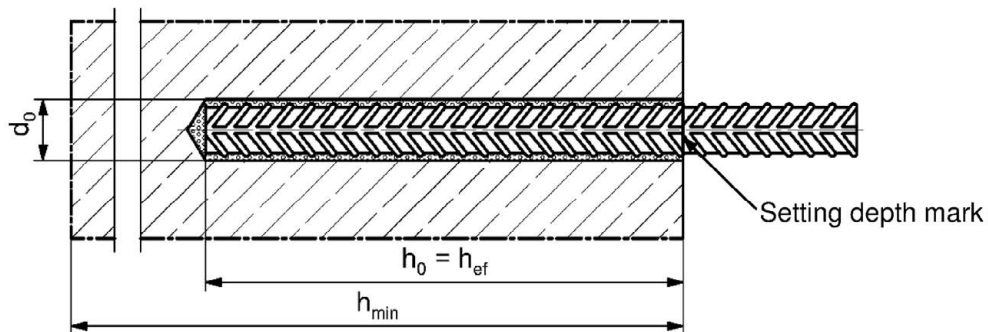

Figures not to scale

fischer Superbond

Intended use
Installation parameters reinforcing bars

Annex B 7

Appendix 16/ 40

Table B8.1: Installation parameters for **fischer rebar anchor FRA**

Rebar anchor FRA		Thread	M12 ¹⁾	M16	M20	M24
Nominal diameter of the bar	ϕ	[mm]	12	16	20	25
Width across flats	SW		19	24	30	36
Nominal drill hole diameter	d_0		14	16	20	30
Drill hole depth	h_0		$h_{ef} + l_e$			
Effective embedment depth	$h_{ef,min}$		70	80	90	96
	$h_{ef,max}$		140	220	300	380
Distance concrete surface to welded joint	l_e		100			
Minimum spacing and minimum edge distance	s_{min} = c_{min}		55	65	85	105
	Diameter of clearance hole in the fixture		$\leq d_f$	14	18	22
Minimum thickness of concrete member	h_{min}		$h_0 + 30$	$h_0 + 2d_0$		
		Maximum installation torque	$\max T_{inst}$	[Nm]	40	60

¹⁾ Both drill hole diameters can be used

fischer rebar anchor FRA

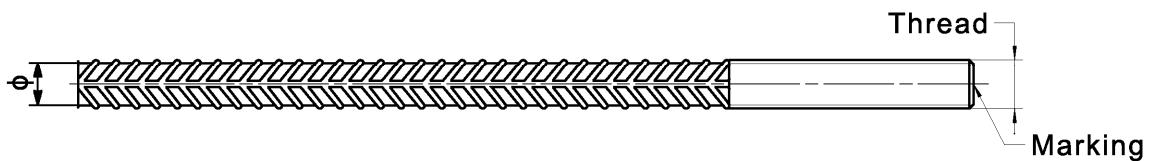

Marking frontal e. g:

- FRA (for stainless steel);
- FRA HCR (for high corrosion resistant steel)

Installation conditions:

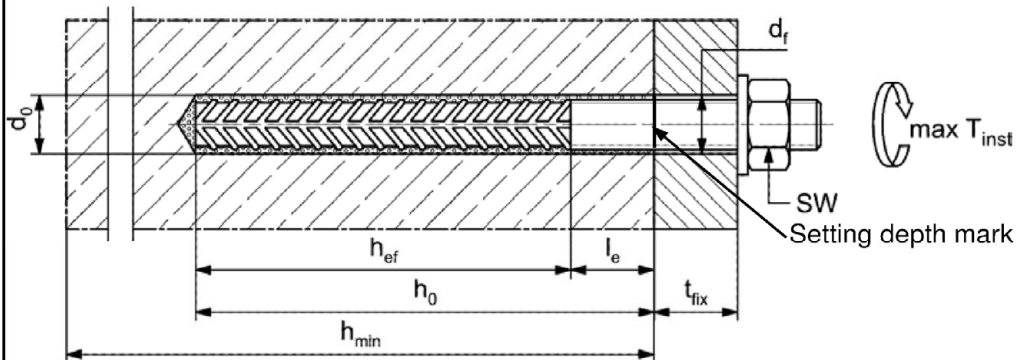

Figures not to scale

fischer Superbond

Intended use
Installation parameters rebar anchor FRA

Annex B 8

Appendix 17/ 40

Table B9.1: Dimension of resin capsule RSB

Resin capsule RSB		RSB 8	RSB 10 mini	RSB 10	RSB 12 mini	RSB 12	RSB 16 mini	RSB 16	RSB 16 E	RSB 20	RSB 20 E / 24	RSB 30
Capsule diameter	d_p	9,0	10,5		12,5		16,5			23,0		27,5
Capsule length	L_p	85	72	90	72	97	72	95	123	160	190	260

**Table B9.2: Assignment of resin capsule RSB to fischer anchor rod RG M**

Anchor rod RG M		M8	M10	M12	M16	M20	M24	M30
Effective embedment depth	$h_{ef,1}$ [mm]	---	75	75	95	---	---	---
Related capsule RSB	[-]	---	10 mini	12 mini	16 mini	---	---	---
Effective embedment depth	$h_{ef,2}$ [mm]	80	90	110	125	170	210	280
Related capsule RSB	[-]	8	10	12	16	20	20 E / 24	30
Effective embedment depth	$h_{ef,3}$ [mm]	---	150	150	190	210	---	---
Related capsule RSB	[-]	---	2 x 10 mini	2 x 12 mini	2 x 16 mini	20 E / 24	---	---

Table B9.3: Assignment of resin capsule RSB to fischer internal threaded anchor RG MI

Internal threaded anchor RG MI		M8	M10	M12	M16	M20
Effective embedment depth	h_{ef} [mm]	90	90	125	160	200
Related capsule RSB	[-]	10	12	16	16 E	20 E / 24

Figures not to scale

fischer Superbond

Intended use

Dimensions of the capsules; Assignment of the capsule to the fischer anchor rod RG M and fischer internal threaded anchor RG MI

Annex B 9

Appendix 18/ 40

Table B10.1: Parameters of the cleaning brush BS / BSB (steel brush with steel bristles)

The size of the cleaning brush refers to the drill hole diameter

Nominal drill hole diameter	d_0		10	12	14	16	18	20	24	25	28	30	32	35	40
Steel brush diameter BS	d_b	[mm]	11	14	16	20		25	26	27	30	40			-
Steel brush diameter BSB	d_b		-	-	-	-		-	-	-	-	-			42



Table B10.2: Maximum **processing time** of the mortar and minimum **curing time** (During the curing time of the mortar the concrete temperature may not fall below the listed minimum temperature. Minimal cartridge temperature +5 °C; minimal resin capsule temperature -15 °C)

Temperature at anchoring base [°C]	Maximum processing time t_{work}		Minimum curing time t_{cure}		
	FIS SB	FIS SB High Speed	FIS SB	FIS SB High Speed	RSB
-30 to -20	---	---	---	---	120 h
> -20 to -15	---	60 min	---	24 h	48 h
> -15 to -10	60 min	30 min	36 h	8 h	30 h
> -10 to -5	30 min	15 min	24 h	3 h	16 h
> -5 to 0	20 min	10 min	8 h	2 h	10 h
> 0 to 5	13 min	5 min	4 h	1 h	45 min
> 5 to 10	9 min	3 min	2 h	45 min	30 min
> 10 to 20	5 min	2 min	1 h	30 min	20 min
> 20 to 30	4 min	1 min	45 min	15 min	5 min
> 30 to 40	2 min	---	30 min	---	3 min

Figures not to scale

fischer Superbond







Intended use
 Cleaning brush (steel brush)
 Processing time and curing time

Annex B 10

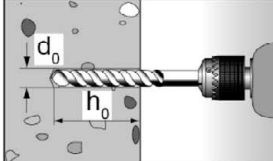
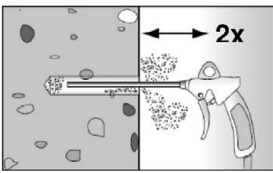
Appendix 19/ 40

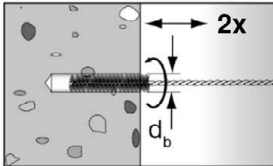
Installation instructions part 1; Injection mortar system FIS SB

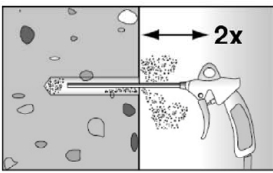
Drilling and cleaning the hole (hammer drilling with standard drill bit)

1		<p>Drill the hole. Nominal drill hole diameter d_0 and drill hole depth h_0 see tables B4.1, B6.1, B7.1, B8.1</p>	
2		<p>Clean the drill hole: Blow out the drill hole twice, with oil free compressed air ($p \geq 6$ bar) In uncracked concrete the use of the manual blow-out pump ABG is possible (Installation parameters: $d_0 < 18$ mm and $h_{ef} < 10d$)</p>	
3		<p>Brush the drill hole twice. For drill hole diameter ≥ 30 mm use a power drill. For deep holes use an extension. Corresponding brushes see table B10.1</p>	
4		<p>Clean the drill hole: Blow out the drill hole twice, with oil free compressed air ($p \geq 6$ bar) In uncracked concrete the use of the manual blow-out pump ABG is possible (Installation parameters: $d_0 < 18$ mm and $h_{ef} < 10d$)</p>	

Go to step 5 (Annex B 12)

Drilling and cleaning the hole (hammer drilling with hollow drill bit)

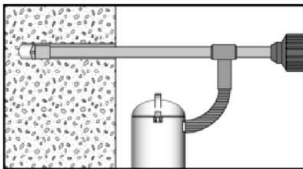
1		<p>Check a suitable hollow drill (see table B1.1) for correct operation of the dust extraction</p>
2		<p>Use a suitable dust extraction system, e. g. fischer FVC 35 M or a comparable dust extraction system with equivalent performance data. Drill the hole with hollow drill bit. The dust extraction system has to extract the drill dust nonstop during the drilling process and must be adjusted to maximum power. Nominal drill hole diameter d_0 and drill hole depth h_0 see tables B4.1, B6.1, B7.1, B8.1</p>

Go to step 5 (Annex B 12)

fischer Superbond





Intended use
Installation instructions part 1; injection mortar system FIS SB

Annex B 11

Appendix 20/ 40

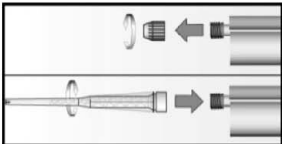
Installation instructions part 2; injection mortar system FIS SB

Preparing the cartridge

5		<p>Remove the sealing cap Screw on the static mixer (the spiral in the static mixer must be clearly visible)</p>
6		 <p>Place the cartridge into the dispenser</p>
7		 <p>Extrude approximately 10 cm of material out until the resin is evenly grey in colour. Do not use mortar that is not uniformly grey</p>

Injection of the mortar

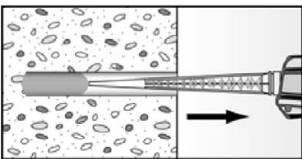
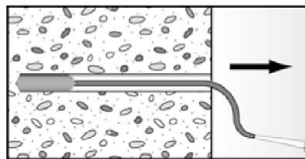
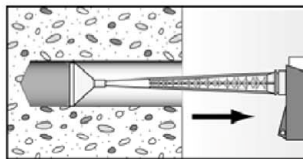
8	 <p>Fill approximately 2/3 of the drill hole with mortar. Always begin from the bottom of the hole and avoid bubbles</p>	 <p>For drill hole depth ≥ 150 mm use an extension tube</p>	 <p>For overhead installation, deep holes ($h_0 > 250$ mm) or drill hole diameter ($d_0 \geq 40$ mm) use an injection-adapater</p>
---	---	--	--

Go to step 9 (Annex B 13)

fischer Superbond



Intended use
Installation instructions part 2; injection mortar system FIS SB

Annex B 12

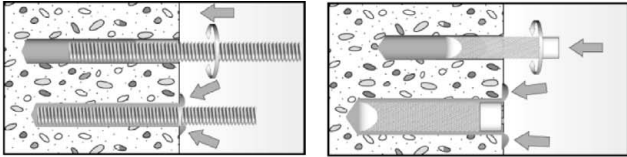
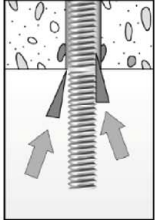
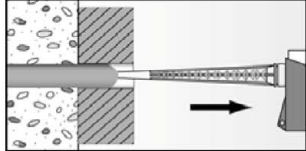

Appendix 21/ 40

Installation instructions part 3; injection mortar system FIS SB

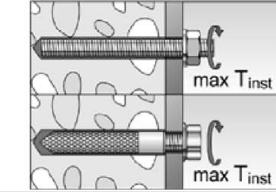
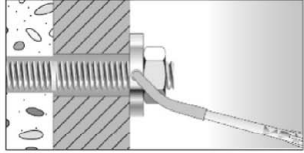
Installation of anchor rods or fischer internal threaded anchors RG MI

9		<p>Only use clean and oil-free metal part. Mark the setting depth of the metal part. Push the anchor rod or fischer internal threaded RG MI anchor down to the bottom of the hole, turning it slightly while doing so. After inserting the metal part, excess mortar must be emerged around the anchor element. If not, pull out the metal part immediately and reinject mortar.</p>
	 <p>For overhead installations support the metal part with wedges. (e. g. fischer centering wedges)</p>	 <p>For push through installation fill the annular gap with mortar</p>
11	 <p>Wait for the specified curing time t_{cure} see table B10.2</p>	<p>12</p>  <p>Mounting the fixture $\max T_{inst}$ see tables B4.1 and B6.1</p>
Option		<p>After the minimum curing time is reached, the gap between metal part and fixture (annular clearance) may be filled with mortar via the fischer filling disc. Compressive strength $\geq 50 \text{ N/mm}^2$ (e.g. fischer injection mortars FIS HB, FIS SB, FIS V, FIS EM Plus) ATTENTION: Using fischer filling disc reduces t_{fix} (usable length of the anchor)</p>

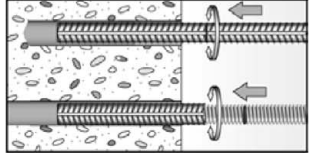
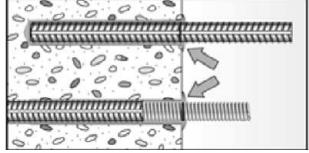
Installation reinforcing bars and fischer rebar anchor FRA

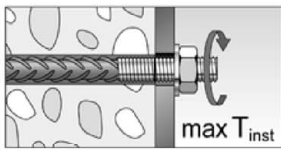
10		<p>Only use clean and oil-free reinforcing bars or fischer FRA. Mark the setting depth. Turn while using force to push the reinforcement bar or the fischer FRA into the filled hole up to the setting depth mark</p>
		<p>When the setting depth mark is reached, excess mortar must be emerged from the mouth of the drill hole. If not, pull out the anchor element immediately and reinject mortar.</p>
11	 <p>Wait for the specified curing time t_{cure} see table B10.2</p>	<p>12</p>  <p>Mounting the fixture $\max T_{inst}$ see table B8.1</p>

fischer Superbond

Intended use
 Installation instructions part 3; injection mortar system FIS SB

Annex B 13

Appendix 22/ 40

Installation instructions part 4; resin capsule RSB

Drilling and cleaning the hole (hammer drilling with standard drill bit)

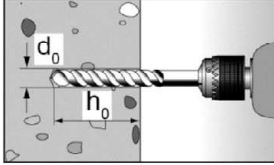
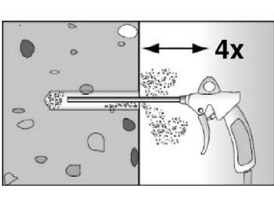
1		<p>Drill the hole. Nominal drill hole diameter d_0 and drill hole depth h_0 see tables B5.1 and B6.1</p>
2		<p>Clean the drill hole: Blow out the drill hole four times, with oil free compressed air ($p \geq 6$ bar) In uncracked concrete the use of the manual blow-out pump ABG is possible (Installation parameters: $d_0 < 18$ mm and $h_{ef} < 10d$)</p>



Go to step 6 (Annex B 15)

Drilling and cleaning the hole (wet drilling with diamond drill bit)

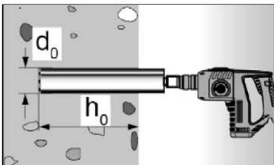
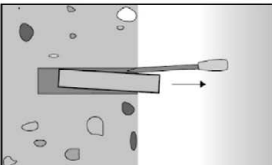
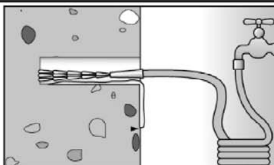
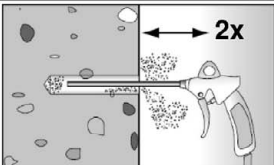
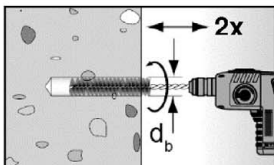
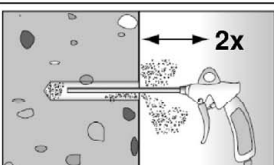
1		<p>Drill the hole. Drill hole diameter d_0 and drill hole depth h_0 see tables B5.1 and B6.1</p>		<p>Break the drill core and remove it</p>
2		<p>Flush the drill hole with clean water until it flows clear</p>		
3		<p>Blow out the drill hole twice, using oil-free compressed air ($p > 6$ bar)</p>		
4		<p>Brush the drill hole twice using a power drill. Corresponding brushes see table B10.1</p>		
5		<p>Blow out the drill hole twice, using oil-free compressed air ($p > 6$ bar)</p>		

Go to step 6 (Annex B 15)

fischer Superbond

Intended use
Installation instructions part 4; resin capsule RSB

Annex B 14

Appendix 23/ 40

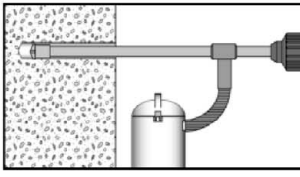

Installation instructions part 5; resin capsule RSB

Drilling and cleaning the hole (hammer drilling with hollow drill bit)

1		<p>Check a suitable hollow drill (see table B2.1) for correct operation of the dust extraction</p>
2		<p>Use a suitable dust extraction system, e. g. fischer FVC 35 M or a comparable dust extraction system with equivalent performance data.</p> <p>Drill the hole with hollow drill bit. The dust extraction system has to extract the drill dust nonstop during the drilling process and must be adjusted to maximum power. Nominal drill hole diameter d_0 and drill hole depth h_0 see tables B5.1 and B6.1</p>

Go to step 6 (Annex B 15)

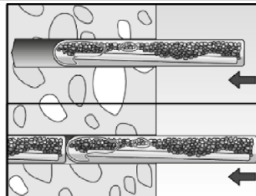
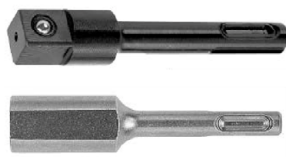
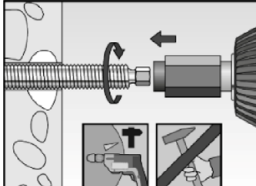
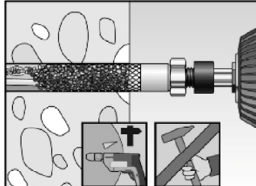
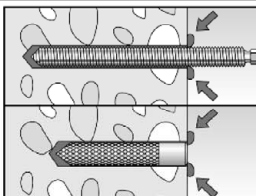
Installation fischer anchor rod RG M or fischer internal threaded anchor RG MI

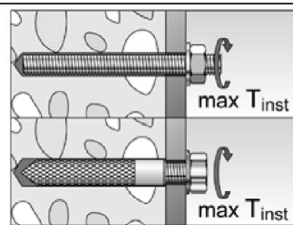
6		<p>Insert the resin capsule into the drill hole by hand. Suitable resin capsule RSB or RSB mini see table B9.2.</p>	 <p>Depending on the metal part being installed, use a suitable setting tool</p>
7			<p>Only use clean and grease-free metal parts. Using a suitable adapter, drive the fischer anchor rod RG M or the fischer internal threaded anchor RG MI into the capsule using a hammer drill set on rotary hammer action. Stop when the metal parts reaches the bottom of the hole and is set to the correct embedment depth</p>
8		<p>When reaching the correct embedment depth, excess mortar must emerge from the mouth of the drill hole. If not, the metal parts must be pulled out directly and a second resin capsule must be pushed into the drill hole. Setting process must be repeated (Step 7)</p>	
9	 <p>Wait for the specified curing time, t_{cure} see table B10.2</p>	<p>10</p>  <p>Mounting the fixture $max T_{inst}$ see tables B5.1 and B6.1</p>	

fischer Superbond

Intended use
Installation instructions part 5; resin capsule RSB

Annex B 15

Appendix 24/ 40

Table C1.1: Characteristic values for **steel failure** under tension / shear load of **fischer anchor rods** and **standard threaded rods**

Anchor rod / standard threaded rod		M8	M10	M12	M16	M20	M24	M27	M30			
Bearing capacity under tension load, steel failure ³⁾												
Characteristic resistance $N_{Rk,s}$	Steel zinc plated	Property class	4.8	[kN]	15(13)	23(21)	33	63	98	141	184	224
			5.8		19(17)	29(27)	43	79	123	177	230	281
			8.8		29(27)	47(43)	68	126	196	282	368	449
	Stainless steel R and high corrosion resistant steel HCR	Property class	50	19	29	43	79	123	177	230	281	
			70	26	41	59	110	172	247	322	393	
			80	30	47	68	126	196	282	368	449	
Partial factors ¹⁾												
Partial factor $\gamma_{Ms,N}$	Steel zinc plated	Property class	4.8	[-]	1,50							
			5.8		1,50							
			8.8		1,50							
	Stainless steel R and high corrosion resistant steel HCR	50	2,86									
		70	1,50 ²⁾ / 1,87									
		80	1,60									
Bearing capacity under shear load, steel failure ³⁾												
without lever arm												
Characteristic resistance $V_{Rk,s}$	Steel zinc plated	Property class	4.8	[kN]	9(8)	14(13)	20	38	59	85	110	135
			5.8		11(10)	17(16)	25	47	74	106	138	168
			8.8		15(13)	23(21)	34	63	98	141	184	225
	Stainless steel R and high corrosion resistant steel HCR	Property class	50		9	15	21	39	61	89	115	141
			70		13	20	30	55	86	124	161	197
			80		15	23	34	63	98	141	184	225
Ductility factor	k_7	[-]	1,0									
with lever arm												
Characteristic resistance $M_{Rk,s}$	Steel zinc plated	Property class	4.8	[Nm]	15(13)	30(27)	52	133	259	448	665	899
			5.8		19(16)	37(33)	65	166	324	560	833	1123
			8.8		30(26)	60(53)	105	266	519	896	1333	1797
	Stainless steel R and high corrosion resistant steel HCR	Property class	50		19	37	65	166	324	560	833	1123
			70		26	52	92	232	454	784	1167	1573
			80		30	60	105	266	519	896	1333	1797
Partial factors ¹⁾												
Partial factor $\gamma_{Ms,V}$	Steel zinc plated	Property class	4.8	[-]	1.25							
			5.8		1.25							
			8.8		1.25							
	Stainless steel R and high corrosion resistant steel HCR	Property class	50		2.38							
			70		1.25 ²⁾ / 1.56							
			80		1.33							

¹⁾ In absence of other national regulations

²⁾ Only admissible for high corrosion resistant steel C, with $f_{yk} / f_{uk} \geq 0,8$ and $A_s > 12\%$ (e.g. fischer anchor rods)

³⁾ Values in brackets are valid for undersized threaded rods with smaller stress area A_s for hotdip galvanized standard threaded rods according to EN ISO 10684:2004+AC:2009

fischer Superbond

Performances

Characteristic values for steel failure capacity of fischer anchor rods and standard threaded rods

Annex C 1

Appendix 25/ 40

Table C2.1: Characteristic values for **steel failure** under tension / shear load of **fischer internal threaded anchors RG MI**

fischer internal threaded anchors RG MI				M8	M10	M12	M16	M20	
Bearing capacity under tension load, steel failure									
Charact. resistance with screw	$N_{Rk,s}$	Property class	5.8	[kN]	19	29	43	79	123
			8.8		29	47	68	108	179
		Property class 70	R		26	41	59	110	172
			HCR		26	41	59	110	172
Partial factors¹⁾									
Partial factors	$\gamma_{Ms,N}$	Property class	5.8	[-]	1,50				
			8.8		1,50				
		Property class 70	R		1,87				
			HCR		1,87				
Bearing capacity under shear load, steel failure									
Without lever arm									
Charact. resistance with screw	$V^0_{Rk,s}$	Property class	5.8	[kN]	9,2	14,5	21,1	39,2	62,0
			8.8		14,6	23,2	33,7	54,0	90,0
		Property class 70	R		12,8	20,3	29,5	54,8	86,0
			HCR		12,8	20,3	29,5	54,8	86,0
Ductility factor		k_7	[-]	1,0					
With lever arm									
Charact. resistance with screw	$M^0_{Rk,s}$	Property class	5.8	[Nm]	20	39	68	173	337
			8.8		30	60	105	266	519
		Property class 70	R		26	52	92	232	454
			HCR		26	52	92	232	454
Partial factors¹⁾									
Partial factors	$\gamma_{Ms,V}$	Property class	5.8	[-]	1,25				
			8.8		1,25				
		Property class 70	R		1,56				
			HCR		1,56				

¹⁾ In absence of other national regulations

fischer Superbond

Performances

Characteristic values for steel failure under tension / shear load
fischer internal threaded anchor RG MI

Annex C 2

Appendix 26/ 40

Table C3.1: Characteristic values for **steel failure** under tension / shear load of reinforcing bars

Nominal diameter of the bar	ϕ	8	10	12	14	16	20	25	28	32
Bearing capacity under tension load, steel failure										
Characteristic resistance	$N_{Rk,s}$	[kN]	$A_s \cdot f_{uk}^{1)}$							
Bearing capacity under shear load, steel failure										
Without lever arm										
Characteristic resistance	$V_{Rk,s}$	[kN]	$0,5 \cdot A_s \cdot f_{uk}^{1)}$							
Ductility factor	k_7	[-]	1,0							
With lever arm										
Characteristic resistance	$M^0_{Rk,s}$	[Nm]	$1,2 \cdot W_{el} \cdot f_{uk}^{1)}$							

¹⁾ f_{uk} or f_{yk} respectively must be taken from the specifications of the reinforcing bar

Table C3.2: Characteristic values for **steel failure** under tension / shear load of **fischer rebar anchors FRA**

fischer rebar anchor FRA		M12	M16	M20	M24	
Bearing capacity under tension load, steel failure						
Characteristic resistance	$N_{Rk,s}$	[kN]	63	111	173	270
Partial factor¹⁾						
Partial factor	$\gamma_{Ms,N}$	[-]	1,4			
Bearing capacity under shear load, steel failure						
Without lever arm						
Characteristic resistance	$V_{Rk,s}$	[kN]	30	55	86	124
Ductility factor	k_7	[-]	1,0			
With lever arm						
Characteristic resistance	$M^0_{Rk,s}$	[Nm]	92	233	454	785
Partial factor¹⁾						
Partial factor	$\gamma_{Ms,V}$	[-]	1,56			

¹⁾ In absence of other national regulations

Table C4.1: Characteristic values for **concrete failure** under tension / shear load

Size		All sizes									
Tension load											
Installation factor	γ_{inst}	[-]	See annex C 5 to C 10 and C 15 to C16								
Factors for the compressive strength of concrete > C20/25											
Increasing factor for τ_{RK}	C25/30	Ψ_c	[-]	1,02							
	C30/37			1,04							
	C35/45			1,07							
	C40/50			1,08							
	C45/55			1,09							
	C50/60			1,10							
Splitting failure											
Edge distance	$h / h_{ef} \geq 2,0$	$C_{cr,sp}$	[mm]	1,0 h_{ef}							
	$2,0 > h / h_{ef} > 1,3$			4,6 h_{ef} - 1,8 h							
	$h / h_{ef} \leq 1,3$			2,26 h_{ef}							
Spacing	$S_{cr,sp}$			2 $C_{cr,sp}$							
Concrete cone failure											
Uncracked concrete	$k_{ucr,N}$	[-]	11,0								
Cracked concrete	$k_{cr,N}$		7,7								
Edge distance	$C_{cr,N}$	[mm]	1,5 h_{ef}								
Spacing	$S_{cr,N}$		2 $C_{cr,N}$								
Factors for sustained tension load											
Temperature range		[-]	24 °C / 40 °C	50 °C / 80 °C	72 °C / 120 °C	90 °C / 150 °C					
Factor	Ψ_{sus}^0	[-]	0,84	0,86	0,84	0,91					
Shear load											
Installation factor	γ_{inst}	[-]	1,0								
Concrete pry-out failure											
Factor for pry-out failure	k_{δ}	[-]	2,0								
Concrete edge failure											
Effective length of fastener in shear loading	l_f	[mm]	for $d_{nom} \leq 24$ mm: min (h_{ef} ; 12 d_{nom}) for $d_{nom} > 24$ mm: min (h_{ef} ; 8 d_{nom} ; 300 mm)								
Calculation diameters											
Size			M8	M10	M12	M16	M20	M24	M27	M30	
fischer anchor rods and standard threaded rods	d_{nom}	[mm]	8	10	12	16	20	24	27	30	
fischer internal threaded anchors RG MI	d_{nom}		12	16	18	22	28	-1)	-1)	-1)	
fischer rebar anchor FRA	d_{nom}		-1)	-1)	12	16	20	25	-1)	-1)	
Size (nominal diameter of the bar)	ϕ		8	10	12	14	16	20	25	28	32
Reinforcing bar	d_{nom}	[mm]	8	10	12	14	16	20	25	28	32

¹⁾ Anchor type not part of the ETA

fischer Superbond

Performances

Characteristic values for concrete failure under tension / shear load

Annex C 4

Appendix 28/ 40

Table C5.1: Characteristic values for combined pull-out and concrete failure for **fischer anchor rods** and **standard threaded rods** in hammer drilled holes in combination with **injection mortar FIS SB; uncracked or cracked concrete**

Anchor rod / standard threaded rod		M8	M10	M12	M16	M20	M24	M27	M30	
Combined pullout and concrete cone failure										
Thread diameter	d [mm]	8	10	12	16	20	24	27	30	
Uncracked concrete										
Characteristic bond resistance in uncracked concrete C20/25										
Hammer-drilling with standard drill bit or hollow drill bit (dry or wet concrete)										
Temperature range	I: 24 °C / 40 °C	$\tau_{Rk,ucr}$ [N/mm ²]	12	13	13	13	13	12	10	10
	II: 50 °C / 80 °C		12	12	12	13	13	12	10	10
	III: 72 °C / 120 °C		10	11	11	11	11	11	9,0	9,0
	IV: 90 °C / 150 °C		10	10	10	11	10	10	8,0	8,0
Installation factors										
Dry or wet concrete	γ_{inst} [-]	1,0								
Cracked concrete										
Characteristic bond resistance in cracked concrete C20/25										
Hammer-drilling with standard drill bit or hollow drill bit (dry or wet concrete)										
Temperature range	I: 24 °C / 40 °C	$\tau_{Rk,cr}$ [N/mm ²]	6,5	7,0	7,5	7,5	7,5	7,5	7,5	7,5
	II: 50 °C / 80 °C		6,0	6,5	7,5	7,5	7,5	7,5	7,0	7,0
	III: 72 °C / 120 °C		5,5	6,0	6,5	6,5	6,5	6,5	6,0	6,0
	IV: 90 °C / 150 °C		5,0	5,5	6,0	6,0	6,0	6,0	5,5	5,5
Installation factors										
Dry or wet concrete	γ_{inst} [-]	1,0								

fischer Superbond

Performances

Characteristic values for combined pull-out and concrete failure for fischer anchor rod and standard threaded rods with injection mortar FIS SB

Annex C 5

Appendix 29/ 40

Table C6.1: Characteristic values for **combined pull-out** and concrete failure for **fischer anchor rods RG M** in hammer or diamond drilled holes in combination with **resin capsule RSB; uncracked or cracked concrete**

Anchor rod RG M			M8	M10	M12	M16	M20	M24	M30
Combined pullout and concrete cone failure									
Thread diameter	d	[mm]	8	10	12	16	20	24	30
Uncracked concrete									
Characteristic bond resistance in uncracked concrete C20/25									
Hammer-drilling with standard drill bit or hollow drill bit (dry or wet concrete as well as water filled hole)									
Temperature range	I: 24 °C / 40 °C	$\tau_{Rk,ucr}$ [N/mm ²]	12	13	13	13	13	12	10
	II: 50 °C / 80 °C		12	12	12	13	13	12	10
	III: 72 °C / 120 °C		10	11	11	11	11	11	9,0
	IV: 90 °C / 150 °C		10	10	10	11	10	10	8,0
Diamond-drilling (dry or wet concrete as well as water filled hole)									
Temperature range	I: 24 °C / 40 °C	$\tau_{Rk,ucr}$ [N/mm ²]	13	13	14	14	14	13	11
	II: 50 °C / 80 °C		12	13	13	14	13	13	10
	III: 72 °C / 120 °C		11	12	12	12	12	11	9,5
	IV: 90 °C / 150 °C		10	11	11	11	11	10	8,5
Installation factors									
Dry or wet concrete	γ_{inst}	[-]	1,0						
Water filled hole	γ_{inst}	[-]	1,2	1,0					
Cracked concrete									
Characteristic bond resistance in cracked concrete C20/25									
Hammer-drilling with standard drill bit or hollow drill bit (dry or wet concrete as well as water filled hole)									
Temperature range	I: 24 °C / 40 °C	$\tau_{Rk,cr}$ [N/mm ²]	6,5	7,0	7,5	7,5	7,5	7,5	7,5
	II: 50 °C / 80 °C		6,0	6,5	7,5	7,5	7,5	7,5	7,0
	III: 72 °C / 120 °C		5,5	6,0	6,5	6,5	6,5	6,5	6,0
	IV: 90 °C / 150 °C		5,0	5,5	6,0	6,0	6,0	6,0	5,5
Diamond-drilling (dry or wet concrete as well as water filled hole)									
Temperature range	I: 24 °C / 40 °C	$\tau_{Rk,cr}$ [N/mm ²]	- ¹⁾	- ¹⁾	- ¹⁾	7,5	7,5	7,5	7,5
	II: 50 °C / 80 °C		- ¹⁾	- ¹⁾	- ¹⁾	7,5	7,5	7,5	7,0
	III: 72 °C / 120 °C		- ¹⁾	- ¹⁾	- ¹⁾	6,5	6,5	6,5	6,5
	IV: 90 °C / 150 °C		- ¹⁾	- ¹⁾	- ¹⁾	6,0	6,0	6,0	6,0
Installation factors									
Dry or wet concrete	γ_{inst}	[-]	1,0						
Water filled hole	γ_{inst}	[-]	1,2	1,0					
¹⁾ No performance assessed									

fischer Superbond

Performances

Characteristic values for combined pull-out and concrete failure for fischer anchor rod RG M with resin capsule RSB

Annex C 6

Appendix 30/ 40

Table C7.1: Characteristic values for **combined pull-out** and concrete failure for **fischer internal threaded anchors RG MI** in hammer drilled holes in combination with **injection mortar FIS SB; uncracked or cracked concrete**

Internal threaded anchor RG MI		M8	M10	M12	M16	M20	
Combined pullout and concrete cone failure							
Sleeve diameter	d [mm]	12	16	18	22	28	
Uncracked concrete							
Characteristic bond resistance in uncracked concrete C20/25							
Hammer-drilling with standard drill bit or hollow drill bit (dry or wet concrete)							
Temperature range	I: 24 °C / 40 °C	$\tau_{Rk,ucr}$ [N/mm ²]	12	12	11	11	9,5
	II: 50 °C / 80 °C		12	11	11	10	9,0
	III: 72 °C / 120 °C		11	10	10	9,0	8,0
	IV: 90 °C / 150 °C		10	9,5	9,0	8,5	7,5
Installation factors							
Dry or wet concrete	γ_{inst} [-]					1,0	
Cracked concrete							
Characteristic bond resistance in cracked concrete C20/25							
Hammer-drilling with standard drill bit or hollow drill bit (dry or wet concrete)							
Temperature range	I: 24 °C / 40 °C	$\tau_{Rk,cr}$ [N/mm ²]					5,0
	II: 50 °C / 80 °C						5,0
	III: 72 °C / 120 °C						4,5
	IV: 90 °C / 150 °C						4,0
Installation factors							
Dry or wet concrete	γ_{inst} [-]					1,0	

fischer Superbond

Performances
 Characteristic values for combined pull-out and concrete failure for fischer internal threaded anchor RG MI with injection mortar FIS SB

Table C8.1: Characteristic values for **combined pull-out** and concrete failure for **fischer internal threaded anchors RG MI** in hammer or diamond drilled holes in combination with **resin capsule RSB; uncracked or cracked concrete**

Internal threaded anchor RG MI			M8	M10	M12	M16	M20
Combined pullout and concrete cone failure							
Sleeve diameter	d	[mm]	12	16	18	22	28
Uncracked concrete							
Characteristic bond resistance in uncracked concrete C20/25							
Hammer-drilling with standard drill bit or hollow drill bit (dry or wet concrete as well as water filled hole)							
Temperature range	I: 24 °C / 40 °C	$\tau_{Rk,ucr}$ [N/mm ²]	12	12	11	11	9,5
	II: 50 °C / 80 °C		12	11	11	10	9,0
	III: 72 °C / 120 °C		11	10	10	9,0	8,0
	IV: 90 °C / 150 °C		10	9,5	9,0	8,5	7,5
Diamond-drilling (dry or wet concrete as well as water filled hole)							
Temperature range	I: 24 °C / 40 °C	$\tau_{Rk,ucr}$ [N/mm ²]	13	12	12	11	10
	II: 50 °C / 80 °C		13	12	12	11	9,5
	III: 72 °C / 120 °C		11	11	10	9,5	8,5
	IV: 90 °C / 150 °C		10	10	9,5	9,0	8,0
Installation factors							
Dry or wet concrete	γ_{inst}	[-]	1,0				
Water filled hole			1,2	1,0			
Cracked concrete							
Characteristic bond resistance in cracked concrete C20/25							
Hammer-drilling with standard drill bit or hollow drill bit (dry or wet concrete as well as water filled hole)							
Temperature range	I: 24 °C / 40 °C	$\tau_{Rk,cr}$ [N/mm ²]	5,0				
	II: 50 °C / 80 °C		5,0				
	III: 72 °C / 120 °C		4,5				
	IV: 90 °C / 150 °C		4,0				
Diamond-drilling (dry or wet concrete as well as water filled hole)							
Temperature range	I: 24 °C / 40 °C	$\tau_{Rk,cr}$ [N/mm ²]	- ¹⁾	5,0			
	II: 50 °C / 80 °C		- ¹⁾	5,0			
	III: 72 °C / 120 °C		- ¹⁾	4,5			
	IV: 90 °C / 150 °C		- ¹⁾	4,0			
Installation factors							
Dry or wet concrete	γ_{inst}	[-]	1,0				
Water filled hole			1,2	1,0			

¹⁾ No performance assessed

fischer Superbond

Performances

Characteristic values for combined pull-out and concrete failure for fischer internal threaded anchor RG MI with resin capsule RSB

Annex C 8

Appendix 32/ 40

Table C9.1: Characteristic values for **combined pull-out** and concrete failure for **reinforcing bars** in hammer drilled holes in combination with **injection mortar FIS SB; uncracked or cracked concrete**

Nominal diameter of the bar		ϕ	8	10	12	14	16	20	25	28	32		
Combined pullout and concrete cone failure													
Bar diameter		d	[mm]	8	10	12	14	16	20	25	28	32	
Uncracked concrete													
Characteristic bond resistance in uncracked concrete C20/25													
<u>Hammer-drilling with standard drill bit or hollow drill bit (dry or wet concrete)</u>													
Tem- perature range	I: 24 °C / 40 °C		$\tau_{RK,ucr}$	[N/mm ²]	8,0	8,5	9,0	9,5	9,5	10	9,5	9,0	7,5
	II: 50 °C / 80 °C				8,0	8,5	9,0	9,0	9,5	9,5	9,0	8,5	7,5
	III: 72 °C / 120 °C				7,0	7,5	8,0	8,0	8,5	8,5	8,0	7,5	6,5
	IV: 90 °C / 150 °C				6,5	7,0	7,0	7,5	7,5	8,0	7,5	7,0	6,0
Installation factors													
Dry or wet concrete		γ_{inst}	[-]	1,0									
Cracked concrete													
Characteristic bond resistance in cracked concrete C20/25													
<u>Hammer-drilling with standard drill bit or hollow drill bit (dry or wet concrete)</u>													
Tem- perature range	I: 24 °C / 40 °C		$\tau_{RK,cr}$	[N/mm ²]	4,5	6,0	6,0	6,0	7,0	6,0	6,0	6,0	6,0
	II: 50 °C / 80 °C				4,5	5,5	5,5	5,5	6,5	6,0	6,0	6,0	6,0
	III: 72 °C / 120 °C				4,0	5,0	5,0	5,0	6,0	5,5	5,5	5,5	5,5
	IV: 90 °C / 150 °C				3,5	4,5	4,5	4,5	5,5	5,0	5,0	5,0	5,0
Installation factors													
Dry or wet concrete		γ_{inst}	[-]	1,0									

fischer Superbond

Performances

Characteristic values for combined pull-out and concrete failure for reinforcing bars with injection mortar FIS SB

Annex C 9

Appendix 33/ 40

Table C10.1: Characteristic values for **combined pull-out** and concrete failure for **fischer rebar anchors FRA** in hammer drilled holes in combination with **injection mortar FIS SB; uncracked or cracked concrete**

fischer rebar anchor FRA		M12	M16	M20	M24	
Combined pullout and concrete cone failure						
Bar diameter	d [mm]	12	16	20	25	
Uncracked concrete						
Characteristic bond resistance in uncracked concrete C20/25						
<u>Hammer-drilling with standard drill bit or hollow drill bit (dry or wet concrete)</u>						
Tem- perature range	I: 24 °C / 40 °C	$\tau_{Rk,ucr}$ [N/mm ²]	9,0	9,5	10	9,5
	II: 50 °C / 80 °C		9,0	9,5	9,5	9,0
	III: 72 °C / 120 °C		8,0	8,5	8,5	8,0
	IV: 90 °C / 150 °C		7,0	7,5	8,0	7,5
Installation factors						
Dry or wet concrete	γ_{inst}	[-]	1,0			
Cracked concrete						
Characteristic bond resistance in cracked concrete C20/25						
<u>Hammer-drilling with standard drill bit or hollow drill bit (dry or wet concrete)</u>						
Tem- perature range	I: 24 °C / 40 °C	$\tau_{Rk,cr}$ [N/mm ²]	6,0	7,0	6,0	6,0
	II: 50 °C / 80 °C		5,5	6,5	6,0	6,0
	III: 72 °C / 120 °C		5,0	6,0	5,5	5,5
	IV: 90 °C / 150 °C		4,5	5,5	5,0	5,0
Installation factors						
Dry or wet concrete	γ_{inst}	[-]	1,0			

fischer Superbond

Performances

Characteristic values for combined pull-out and concrete failure for fischer rebar anchors FRA with injection mortar FIS SB

Annex C 10

Appendix 34/ 40

Table C11.1: Displacements for anchor rods

Anchor rod		M8	M10	M12	M16	M20	M24	M27	M30
Displacement-Factors for tension load¹⁾									
Uncracked or cracked concrete; Temperature range I, II, III, IV									
δ_{N0} -Factor	[mm/(N/mm ²)]	0,07	0,08	0,09	0,10	0,11	0,12	0,12	0,13
$\delta_{N\infty}$ -Factor		0,13	0,14	0,15	0,17	0,17	0,18	0,19	0,19
Displacement-Factors for shear load²⁾									
Uncracked or cracked concrete; Temperature range I, II, III, IV									
δ_{V0} -Factor	[mm/kN]	0,18	0,15	0,12	0,09	0,07	0,06	0,05	0,05
$\delta_{V\infty}$ -Factor		0,27	0,22	0,18	0,14	0,11	0,09	0,08	0,07
1) Calculation of effective displacement: $\delta_{N0} = \delta_{N0}\text{-Factor} \cdot \tau_{Ed}$ $\delta_{N\infty} = \delta_{N\infty}\text{-Factor} \cdot \tau_{Ed}$ (τ_{Ed} : Design value of the applied tensile stress)					2) Calculation of effective displacement: $\delta_{V0} = \delta_{V0}\text{-Factor} \cdot V_{Ed}$ $\delta_{V\infty} = \delta_{V\infty}\text{-Factor} \cdot V_{Ed}$ (V_{Ed} : Design value of the applied shear force)				

Table C11.2: Displacements for fischer internal threaded anchors RG MI

Internal threaded anchor RG MI		M8	M10	M12	M16	M20
Displacement-Factors for tension load¹⁾						
Uncracked or cracked concrete; Temperature range I, II, III, IV						
δ_{N0} -Factor	[mm/(N/mm ²)]	0,09	0,10	0,10	0,11	0,19
$\delta_{N\infty}$ -Factor		0,13	0,15	0,15	0,17	0,19
Displacement-Factors for shear load²⁾						
Uncracked or cracked concrete; Temperature range I, II, III, IV						
δ_{V0} -Factor	[mm/kN]	0,12	0,09	0,08	0,07	0,05
$\delta_{V\infty}$ -Factor		0,18	0,14	0,12	0,10	0,08
1) Calculation of effective displacement: $\delta_{N0} = \delta_{N0}\text{-Factor} \cdot \tau_{Ed}$ $\delta_{N\infty} = \delta_{N\infty}\text{-Factor} \cdot \tau_{Ed}$ (τ_{Ed} : Design value of the applied tensile stress)				2) Calculation of effective displacement: $\delta_{V0} = \delta_{V0}\text{-Factor} \cdot V_{Ed}$ $\delta_{V\infty} = \delta_{V\infty}\text{-Factor} \cdot V_{Ed}$ (V_{Ed} : Design value of the applied shear force)		

fischer Superbond

Performances

Displacements for anchor rods and fischer internal threaded anchors RG MI

Annex C 11

Appendix 35/ 40

Table C12.1: Displacements for reinforcing bars

Nominal diameter of the bar ϕ	8	10	12	14	16	20	25	28	32	
Displacement-Factors for tension load¹⁾										
Uncracked or cracked concrete; Temperature range I, II, III, IV										
δ_{N0} -Factor	[mm/(N/mm ²)]	0,07	0,08	0,09	0,09	0,10	0,11	0,12	0,13	0,13
$\delta_{N\infty}$ -Factor		0,11	0,13	0,13	0,15	0,16	0,16	0,18	0,20	0,20
Displacement-Factors for shear load²⁾										
Uncracked or cracked concrete; Temperature range I, II, III, IV										
δ_{V0} -Factor	[mm/kN]	0,18	0,15	0,12	0,10	0,09	0,07	0,06	0,05	0,05
$\delta_{V\infty}$ -Factor		0,27	0,22	0,18	0,16	0,14	0,11	0,09	0,08	0,06

1) Calculation of effective displacement:

$$\delta_{N0} = \delta_{N0}\text{-Factor} \cdot \tau_{Ed}$$

$$\delta_{N\infty} = \delta_{N\infty}\text{-Factor} \cdot \tau_{Ed}$$

 $(\tau_{Ed}$: Design value of the applied tensile stress)

2) Calculation of effective displacement:

$$\delta_{V0} = \delta_{V0}\text{-Factor} \cdot V_{Ed}$$

$$\delta_{V\infty} = \delta_{V\infty}\text{-Factor} \cdot V_{Ed}$$

 $(V_{Ed}$: Design value of the applied shear force)
Table C12.2: Displacements for fischer rebar anchors FRA

fischer rebar anchor FRA	M12	M16	M20	M24	
Displacement-Factors for tension load¹⁾					
Uncracked or cracked concrete; Temperature range I, II, III, IV					
δ_{N0} -Factor	[mm/(N/mm ²)]	0,09	0,10	0,11	0,12
$\delta_{N\infty}$ -Factor		0,13	0,15	0,16	0,18
Displacement-Factors for shear load²⁾					
Uncracked or cracked concrete; Temperature range I, II, III, IV					
δ_{V0} -Factor	[mm/kN]	0,12	0,09	0,07	0,06
$\delta_{V\infty}$ -Factor		0,18	0,14	0,11	0,09

1) Calculation of effective displacement:

$$\delta_{N0} = \delta_{N0}\text{-Factor} \cdot \tau_{Ed}$$

$$\delta_{N\infty} = \delta_{N\infty}\text{-Factor} \cdot \tau_{Ed}$$

 $(\tau_{Ed}$: Design value of the applied tensile stress)

2) Calculation of effective displacement:

$$\delta_{V0} = \delta_{V0}\text{-Factor} \cdot V_{Ed}$$

$$\delta_{V\infty} = \delta_{V\infty}\text{-Factor} \cdot V_{Ed}$$

 $(V_{Ed}$: Design value of the applied shear force)

fischer Superbond

Performances

Displacements for reinforcing bars and fischer rebar anchors FRA

Annex C 12

Appendix 36/ 40

Table C13.1: Characteristic values for steel failure under tension / shear load of fischer anchor rods and standard threaded rods under seismic action performance category C1 or C2

Anchor rod / standard threaded rod		M8	M10	M12	M16	M20	M24	M27	M30		
Bearing capacity under tension load, steel failure¹⁾											
fischer anchor rods and standard threaded rods, performance category C1²⁾											
Characteristic resistance $N_{Rk,s,C1}$	Steel zinc plated	Property class	5.8	19(17)	29(27)	43	79	123	177	230	281
			8.8	29(27)	47(43)	68	126	196	282	368	449
	Stainless steel R and high corrosion resistant steel HCR		50 [kN]	19	29	43	79	123	177	230	281
			70	26	41	59	110	172	247	322	393
			80	30	47	68	126	196	282	368	449
fischer anchor rods and standard threaded rods, performance category C2²⁾											
Characteristic resistance $N_{Rk,s,C2}$	Steel zinc plated	Property class	5.8	- ⁴⁾	- ⁴⁾	39	72	108	177	- ⁴⁾	- ⁴⁾
			8.8	- ⁴⁾	- ⁴⁾	61	116	173	282	- ⁴⁾	- ⁴⁾
	Stainless steel R and high corrosion resistant steel HCR		50 [-]	- ⁴⁾	- ⁴⁾	39	72	108	177	- ⁴⁾	- ⁴⁾
			70	- ⁴⁾	- ⁴⁾	53	101	152	247	- ⁴⁾	- ⁴⁾
			80	- ⁴⁾	- ⁴⁾	61	116	173	282	- ⁴⁾	- ⁴⁾
Bearing capacity under shear load, steel failure without lever arm¹⁾											
fischer anchor rods, performance category C1²⁾											
Characteristic resistance $V_{Rk,s,C1}$	Steel zinc plated	Property class	5.8	11(10)	17(16)	25	47	74	106	138	168
			8.8	15(13)	23(21)	34	63	98	141	184	225
	Stainless steel R and high corrosion resistant steel HCR		50 [kN]	9	15	21	39	61	89	115	141
			70	13	20	30	55	86	124	161	197
			80	15	23	34	63	98	141	184	225
Standard threaded rods, performance category C1²⁾											
Characteristic resistance $V_{Rk,s,C1}$	Steel zinc plated	Property class	5.8	8(7)	12(11)	17	33	52	74	97	118
			8.8	11	16(14)	24	44	69	99	129	158
	Stainless steel R and high corrosion resistant steel HCR		50 [kN]	6	11	15	27	43	62	81	99
			70	9	14	21	39	60	87	113	138
			80	11	16	24	44	69	99	129	158
fischer anchor rods and standard threaded rods, performance category C2											
Characteristic resistance $V_{Rk,s,C2}$	Steel zinc plated	Property class	5.8	- ⁴⁾	- ⁴⁾	14	27	43	62	- ⁴⁾	- ⁴⁾
			8.8	- ⁴⁾	- ⁴⁾	22	44	69	99	- ⁴⁾	- ⁴⁾
	Stainless steel R and high corrosion resistant steel HCR		50 [-]	- ⁴⁾	- ⁴⁾	14	27	43	62	- ⁴⁾	- ⁴⁾
			70	- ⁴⁾	- ⁴⁾	20	39	60	87	- ⁴⁾	- ⁴⁾
			80	- ⁴⁾	- ⁴⁾	22	44	69	99	- ⁴⁾	- ⁴⁾
Factor for the annular gap	α_{gap}	[-]	0,5 (1,0) ³⁾								

- 1) Partial factors for performance category C1 or C2 see table C14.2; for fischer anchor rods FIS A / RG M the factor for steel ductility is 1,0
- 2) Values in brackets are valid for undersized threaded rods with smaller stress area A_s for hot dip galvanised standard threaded rods according to EN ISO 10684:2004+AC:2009.
- 3) Values in brackets are valid for filled annular gaps between the anchor rod and the through-hole in the attachment. It is necessary to use the fischer filling disc according to Annex A 1 and A 3
- 4) No performance assessed

fischer Superbond

Performances

Characteristic values for steel failure under tension / shear load for fischer anchor rods and standard threaded rods under seismic action (performance category C1 / C2)

Annex C 13

Appendix 37/ 40

Table C14.1: Characteristic values for **steel failure** under tension / shear load for of **reinforcing bars (B500B)** under seismic action performance category **C1**

Nominal diameter of the bar	ϕ	8	10	12	14	16	20	25	28	32	
Bearing capacity under tension load, steel failure¹⁾											
Reinforcing bar B500B acc. to DIN 488-2:2009-08, performance category C1											
Characteristic resistance	$N_{Rk,s,C1}$	[kN]	28	44	63	85	111	173	270	339	443
Bearing capacity under shear load, steel failure without lever arm¹⁾											
Reinforcing bar B500B acc. to DIN 488-2:2009-08, performance category C1											
Characteristic resistance	$V_{Rk,s,C1}$	[kN]	10	15	22	30	39	61	95	119	155

¹⁾ Partial factors for performance category C1 see table C14.2

Table C14.2: Partial factors for **fischer anchor rods, standard threaded rods and reinforcing bars (B500B)** under seismic action performance category **C1 or C2**

Anchor rod / standard threaded rod		M8	M10	M12	M16	M20	M24	M27	M30	
Nominal diameter of the bar	ϕ	8	10	12	14	16	20	25	28	32

Tension load, steel failure¹⁾										
Partial factor $\gamma_{Ms,N}$	Steel zinc plated	Property class	5.8	[-]	1,50					
			8.8		1,50					
	Stainless steel R and high corrosion resistant steel HCR	50	2,86							
		70	1,50 ²⁾ / 1,87							
	Reinforcing bar	B500B	80		1,60					
					1,40					

Shear load, steel failure¹⁾										
Partial factor $\gamma_{Ms,V}$	Steel zinc plated	Property class	5.8	[-]	1,25					
			8.8		1,25					
	Stainless steel R and high corrosion resistant steel HCR	50	2,38							
		70	1,25 ²⁾ / 1,56							
	Reinforcing bar	B500B	80		1,33					
					1,50					

¹⁾ In absence of other national regulations

²⁾ Only admissible for high corrosion resistant steel HCR, with $f_{yk} / f_{uk} \geq 0,8$ and $A_5 > 12\%$ (e.g. fischer anchor rods)

fischer Superbond

Performances

Characteristic values for steel failure under tension / shear load for reinforcing bars under seismic action (performance category C1); partial factors (performance category C1 / C2)

Annex C 14

Appendix 38/ 40

Table C15.1: Characteristic values for **combined pull-out** and concrete failure for **fischer anchor rods** and **standard threaded rods** in hammer drilled holes with **injection mortar FIS SB** or **resin capsule RSB** under seismic action performance category **C1**

Anchor rod / standard threaded rod		M8	M10	M12	M16	M20	M24	M27 ¹⁾	M30	
Characteristic bond resistance, combined pullout and concrete cone failure										
Hammer-drilling with standard drill bit or hollow drill bit (dry or wet concrete; resin capsule RSB additional in water filled holes)										
Temperature range	I: 24 °C / 40 °C	$\tau_{Rk,C1}$ [N/mm ²]	4,6	5,0	5,6	5,6	5,6	5,6	5,6	6,4
	II: 50 °C / 80 °C		4,3	4,6	5,6	5,6	5,6	5,6	5,3	6,0
	III: 72 °C / 120 °C		3,9	4,3	4,9	4,9	4,9	4,9	4,5	5,1
	IV: 90 °C / 150 °C		3,6	3,9	4,5	4,5	4,5	4,5	4,1	4,7

Installation factors

Dry or wet concrete	γ_{inst}	[-]	1,0						
Water filled hole			1,2 ²⁾	1,0 ²⁾					

¹⁾ Only use with injection mortar FIS SB

²⁾ Only use with resin capsule RSB in water filled hole

Table C15.2: Characteristic values for **combined pull-out** and concrete failure for **reinforcing bars** in hammer drilled holes with **injection mortar FIS SB** under seismic action performance category **C1**

Nominal diameter of the bar		ϕ	8	10	12	14	16	20	25	28	32
Characteristic bond resistance, combined pullout and concrete cone failure											
Hammer-drilling with standard drill bit or hollow drill bit (dry or wet concrete)											
Temperature range	I: 24 °C / 40 °C	$\tau_{Rk,C1}$ [N/mm ²]	3,2	4,3	4,5	4,5	5,3	4,5	4,5	4,5	5,1
	II: 50 °C / 80 °C		3,2	3,9	4,1	4,1	4,9	4,5	4,5	4,5	5,1
	III: 72 °C / 120 °C		2,8	3,6	3,8	3,8	4,5	4,1	4,1	4,1	4,7
	IV: 90 °C / 150 °C		2,5	3,2	3,4	3,4	4,1	3,8	3,8	3,8	4,3

Installation factors

Dry or wet concrete	γ_{inst}	[-]	1,0								
---------------------	-----------------	-----	-----	--	--	--	--	--	--	--	--

fischer Superbond

Performances

Characteristic values for combined pull-out and concrete failure under seismic action (performance category C1) for fischer anchor rods, standard threaded rods and reinf. bars

Annex C 15

Appendix 39/ 40

Table C16.1: Characteristic values for **combined pull-out** and concrete failure for **fischer anchor rods** and **standard threaded rods** in hammer drilled holes with **injection mortar FIS SB** under seismic action performance category **C2**

Anchor rod / standard threaded rod		M12	M16	M20	M24	
Characteristic bond resistance, combined pullout and concrete cone failure						
Hammer-drilling with standard drill bit or hollow drill bit (dry or wet concrete)						
Temperature range	I: 24 °C / 40 °C	$\tau_{Rk,C2}$ [N/mm ²]	4,5	3,2	2,6	3,0
	II: 50 °C / 80 °C		4,5	3,2	2,6	3,0
	III: 72 °C / 120 °C		3,9	2,7	2,3	2,6
	IV: 90 °C / 150 °C		3,6	2,5	2,1	2,4

Installation factors

Dry or wet concrete	γ_{inst}	[-]	1,0
---------------------	-----------------	-----	-----

Displacement-Factors for tension load¹⁾

$\delta_{N,C2}$ (DLS)-Factor	[mm/(N/mm ²)]	0,09	0,10	0,11	0,12
$\delta_{N,C2}$ (ULS)-Factor		0,15	0,17	0,17	0,18

Displacement-Factors for shear load²⁾

$\delta_{V,C2}$ (DLS)-Factor	[mm/kN]	0,18	0,10	0,07	0,06
$\delta_{V,C2}$ (ULS)-Factor		0,25	0,14	0,11	0,09

¹⁾ Calculation of effective displacement:

$$\delta_{N,C2} (DLS) = \delta_{N,C2} (DLS)\text{-Factor} \cdot \tau_{Ed}$$

$$\delta_{N,C2} (ULS) = \delta_{N,C2} (ULS)\text{-Factor} \cdot \tau_{Ed}$$

(τ_{Ed} : Design value of the applied tensile stress)

²⁾ Calculation of effective displacement:

$$\delta_{V,C2} (DLS) = \delta_{V,C2} (DLS)\text{-Factor} \cdot V_{Ed}$$

$$\delta_{V,C2} (ULS) = \delta_{V,C2} (ULS)\text{-Factor} \cdot V_{Ed}$$

(V_{Ed} : Design value of the applied shear force)

fischer Superbond

Performances

Characteristic values for combined pull-out and concrete failure under seismic action (performance category C2) for fischer anchor rods and standard threaded rods

Annex C 16

Appendix 40/ 40