

YDEEVNEDEKLARATION

DoP 0258

til ankerbolt fischer EXA (Metalanker til brug i beton)

DA

1. Varetypens unikke identifikationskode: DoP 0258
2. Anvendelsesformål: Eftermonteret befæstelse i ikke-revnet beton, se appendiks, specifikt Bilage B1 - B3.
3. Fabrikant: fischerwerke GmbH & Co. KG, Klaus-Fischer-Str. 1, 72178 Waldachtal, Tyskland
4. Bemyndiget repræsentant: -
5. System(er) til vurdering og kontrol af konstansen af ydeevnen: 1
6. Europæisk vurderingsdokument: EAD 330232-00-0601
ETA-05/0185; 2018-06-19
Europæisk Teknisk Vurdering CSTB - Centre Scientifique et Technique du Bâtiment
Teknisk vurderingsorgan: 2873 TU Darmstadt
Notificeret organ(er)

7. Deklareret ydeevne(r):

Mekanisk modstand og stabilitet (BWR 1)

Karakteristisk modstand for træklast (statisk og quasi-statisk belastning):

Modstand overfor stålsvig: Bilag C1

$E_s = 210\,000\text{ MPa}$

Modstand overfor svigt ved udtrækning: Bilag C1

Modstand overfor svigt af beton-kegle: Bilag C1

Robusthed: Bilag C1

Min. kant og indbyrdes afstand: Bilag B2

Kantafstand til forhindring af flækning under belastning: Bilag C1

$N_{Rk,sp}^{0} = \text{NPD}$

Karakteristisk modstand for tværlast (statisk og quasi-statisk belastning):

Modstand overfor stålsvig (tværlast): Bilag C1

Modstand overfor svigt ved udtrækning: Bilag C1

Modstand overfor svigt af betonkant: Bilag C1

Forskydninger under statisk og quasi-statisk belastning: Bilag C2

Holdbarhed: Bilag A2, B1

Karakteristisk modstand og Forskydninger for seismiske ydelseskategorier C1 og C2:

Modstand overfor stålsvig: NPD

Modstand overfor svigt ved udtrækning: NPD

Brudforlængelse: NPD

Faktor ringhul: NPD

Forskydninger: NPD

Brandbeskyttelse (BWR 2)

Brandegenskaber: Klasse (A1)

Brandbeskyttelse:

Brandbeskyttelse overfor stålsvig (spændingslast): NPD

Brandbeskyttelse overfor svigt ved udtrækning (spændingslast): NPD

Brandbeskyttelse overfor stålsvig (tværlast): NPD

8. Relevant teknisk dokumentation og/eller specifik teknisk dokumentation: -

Ydeevnen for den vare, der er anført ovenfor, er i overensstemmelse med den deklarerede ydeevne. Denne ydeevnedeklaration er udarbejdet i overensstemmelse med forordning (EU) nr. 305/2011 på eneansvar af den fabrikant, der er anført ovenfor.

Underskrevet for fabrikanten og på dennes vegne af:



Dr.-Ing. Oliver Geibig, Administrerende direktør Forretningsenheder og ingeniørarbejde
Tumlingen, 2021-01-15

Jürgen Grün, Administrerende direktør Kemi & Kvalitet

Denne DoP er tilgængelig i forskellige sprogversioner. I tilfælde af fortolkningsmæssig uoverensstemmelse, henvises der til den engelske version, som altid er gældende.

Appendikset indeholder frivillige og udvidede informationer på engelsk. Disse overgår de lokale (sprogneutrale) retslige krav.

Specific Part

1 Technical description of the product

The Fischer Anchor bolt EXA anchor is an anchor made of zinc electroplated steel, with two expansion sleeves in the range of sizes M8, M10, M12, M16 and M20.

The anchor is placed into a drilled hole and anchored by torque-controlled expansion.

The illustration and the description of the product are given in Annexes A.

2 Specification of the intended use

The performances given in Section 3 are only valid if the anchor is used in compliance with the specifications and conditions given in Annexes B.

The provisions made in this European technical assessment are based on an assumed working life of the anchor of 50 years. The indications given on the working life cannot be interpreted as a guarantee given by the producer, but are to be regarded only as a means for choosing the right products in relation to the expected economically reasonable working life of the works.

3 Performance of the product

3.1 Mechanical resistance and stability (BWR 1)

Essential characteristic	Performance
Characteristic tension resistance acc. EN 1992-4	See Annex C1
Characteristic shear resistance acc. EN 1992-4	See Annex C1
Displacements	See Annex C2

3.2 Safety in case of fire (BWR 2)

Essential characteristic	Performance
Reaction to fire	Anchorage satisfies requirements for Class A1

3.3 Hygiene, health and the environment (BWR 3)

Regarding dangerous substances contained in this European technical approval, there may be requirements applicable to the products falling within its scope (e.g. transposed European legislation and national laws, regulations and administrative provisions). In order to meet the provisions of the Construction Products Directive, these requirements need also to be complied with, when and where they apply.

3.4 Safety in use (BWR 4)

For Basic requirement Safety in use the same criteria are valid as for Basic Requirement Mechanical resistance and stability.

3.5 Protection against noise (BWR 5)

Not relevant.

3.6 Energy economy and heat retention (BWR 6)

Not relevant.

3.7 Sustainable use of natural resources (BWR 7)

For the sustainable use of natural resources no performance was determined for this product.

3.8 General aspects relating to fitness for use

Durability and Serviceability are only ensured if the specifications of intended use according to Annex B1 are kept.

4 Assessment and verification of constancy of performance (AVCP)

According to the Decision 96/582/EC of the European Commission¹, as amended, the system of assessment and verification of constancy of performance (see Annex V to Regulation (EU) No 305/2011) given in the following table apply.

Product	Intended use	Level or class	System
Metal anchors for use in concrete	For fixing and/or supporting to concrete, structural elements (which contributes to the stability of the works) or heavy units	—	1

M8, M10 and M12: Cone bolt manufactured by cold - forming:

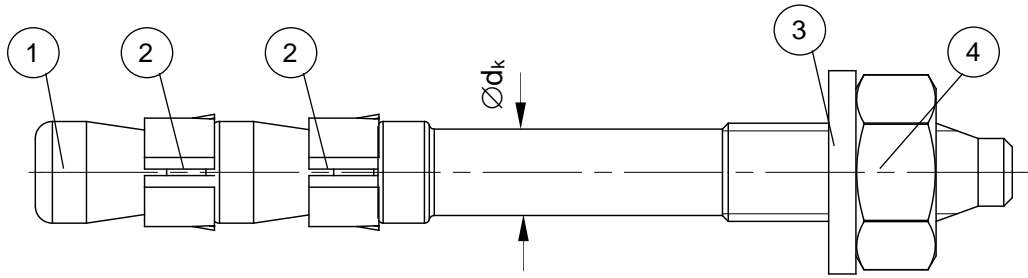

M12, M16 and M20: Cone bolt manufactured by metal - cutting:

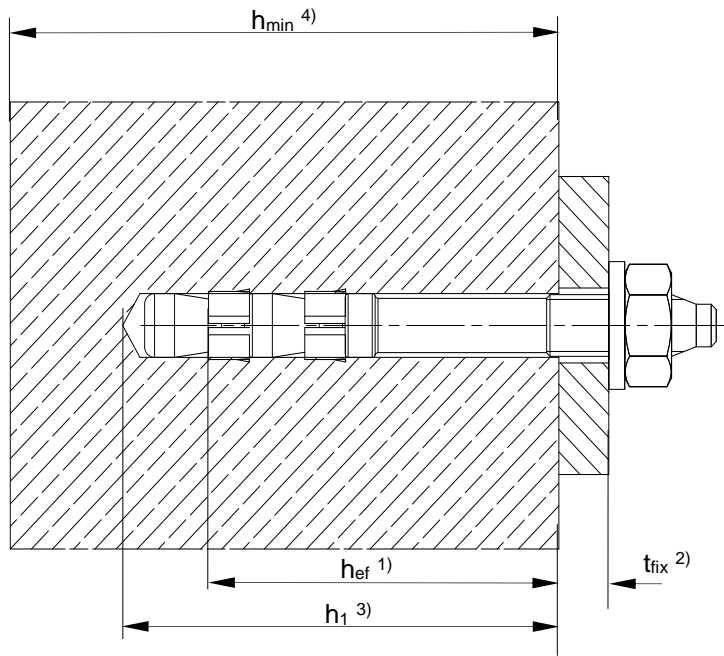
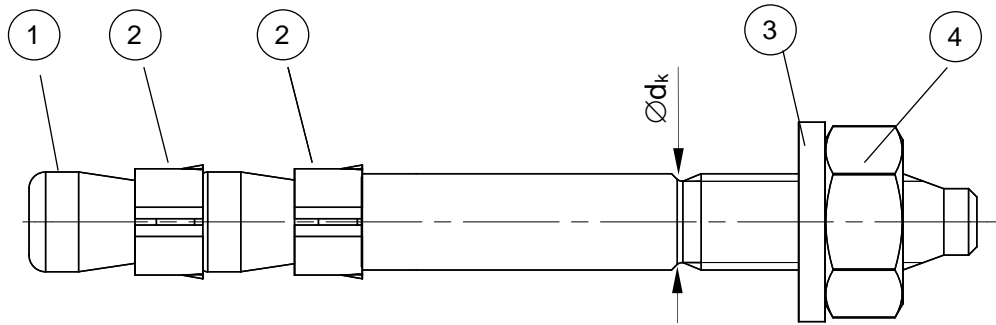

For use in uncracked concrete subject to dry internal conditions only

- ① Cone bolt (cold – formed or metal - cut)
- ② Expansion sleeve
- ③ Washer
- ④ Hexagon nut

- 1) effective anchorage depth
- 2) thickness of fixture
- 3) drill hole depth
- 4) min. thickness of concrete member

fischer Anchor bolt EXA

Product description
Installation condition

Annex A1

Appendix 3 / 9

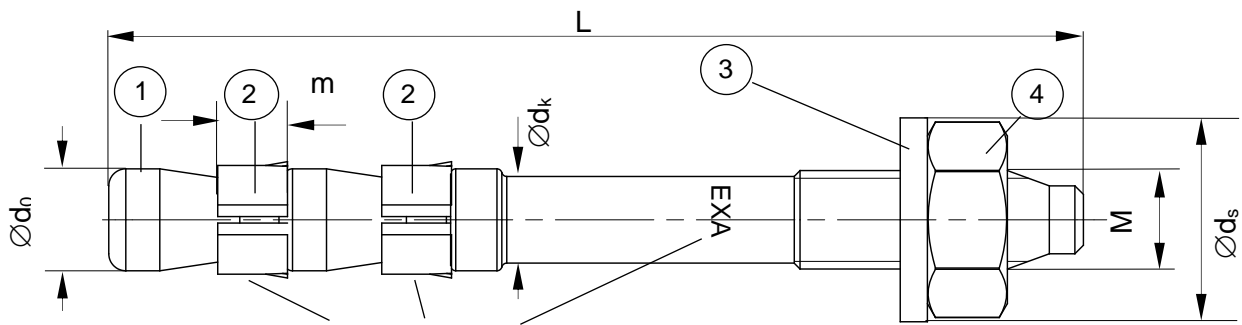

Marking Cone Bolt on lateral surface and/or on sleeves

U EXA 8/28
 works symbol type of anchor thread size maximal thickness of fixture ($t_{fix, max}$)

Table A2.1: Anchor dimensions [mm]

Part	Designation	Dimensions		EXA	EXA	EXA	EXA	EXA
				M8	M10	M12	M16	M20
1	Cone bolt	M		8	10	12	16	20
		$\varnothing d_0$	=	7,9	9,9	11,9	16,0	20,0
		$\varnothing d_k$	=	7,1	8,9	10,8	15,5	18,2
2	Expansion sleeve	m	=	5,3	6,4	7,2	10,3	12
3	Washer	t_s	\geq	1,4	1,8	2,3	2,7	2,7
		$\varnothing d_s$	\geq	15	19	23	29	36
4	Hexagon nut	SW		13	17	19	24	30
	Thickness of fixture t_{fix}	min	\geq	0	0	0	0	0
		max	\leq	200	250	350	400	500
	Length of anchor	L_{min}		68	73	97	122	146
		L_{max}		267	323	446	522	646

Table A2.2: Materials

Part	Designation	Material	Treatment
1	Cone bolt	Cold form steel or free cutting steel	Zinc plated $\geq 5 \mu\text{m}$ according to EN ISO 4042
2	Expansion sleeve	Cold strip, EN 10088-2 or EN 10139	EN 10088-2: --- EN 10139: Zinc plated $\geq 5 \mu\text{m}$ according to EN ISO 4042
3	Washer	Cold strip, EN 10139	Zinc plated $\geq 5 \mu\text{m}$ according to EN ISO 4042;
4	Hexagon nut	Steel, property class 8, EN 20898-2	Nuts M8 and M10 with coating

fischer Anchor bolt EXA

Product description
 Dimensions and materials

Annex A2

Appendix 4 / 9

Specifications of intended use

Anchorage subject to:

- Static and quasi-static loads

Base materials:

- Uncracked concrete
- Reinforced or unreinforced normal weight concrete of strength classes C20/25 at least to C50/60 at most according to EN 206.

Use conditions (Environmental conditions):

- Structures subject to dry internal conditions.

Design:

- The anchorages are designed in accordance with the EN 1992-4 "Design of fastenings for use in concrete" or with ETAG001 Annex C "Design Method for Anchorages" under the responsibility of an engineer experienced in anchorages and concrete work.
- Verifiable calculation notes and drawings are prepared taking account of the loads to be anchored. The position of the anchor is indicated on the design drawings.

Installation:

- Anchor installation carried out by appropriately qualified personnel and under the supervision of the person responsible for technical matters of the site.
- Use of the anchor only as supplied by the manufacturer without exchanging the components of an anchor.
- Anchor installation in accordance with the manufacturer's specifications and drawings and using the appropriate tools.
- Effective anchorage depth, edge distances and spacing not less than the specified values without minus tolerances.
- Hole drilling by hammer drill with conventional bit or hollow drill bit.
- Cleaning of the hole of drilling dust.
- Application of specified torque moment using a calibrated torque wrench.
- In case of aborted hole, drilling of new hole at a minimum distance of twice the depth of the aborted hole, or smaller distance provided the aborted drill hole is filled with high strength mortar and no shear or oblique tension loads in the direction of aborted hole

fischer Anchor bolt EXA

Product description

Specification

Annex B1

Appendix 5 / 9

Table B2.1: Installation parameters

Type of anchor / size		EXA M8	EXA M10	EXA M12	EXA M16	EXA M20
Nominal drill hole diameter	$d_0 = [\text{mm}]$	8	10	12	16	20
Cutting diameter of drill bit	$d_{\text{cut}} \leq [\text{mm}]$	8,45	10,45	12,5	16,5	20,55
Effective anchorage depth	$h_{\text{ef}} \geq [\text{mm}]$	47	49	67	85	103
Depth of drill hole in concrete	$h_1 \geq [\text{mm}]$	60	65	85	110	130
Minimum thickness of concrete member	$h_{\text{min}} \geq [\text{mm}]$	100	100	135	170	205
Diameter of clearance hole in the fixture	$d_f \leq [\text{mm}]$	9	12	14	18	22
Required torque moment	$T_{\text{inst}} = [\text{Nm}]$	14	30	60	80	140

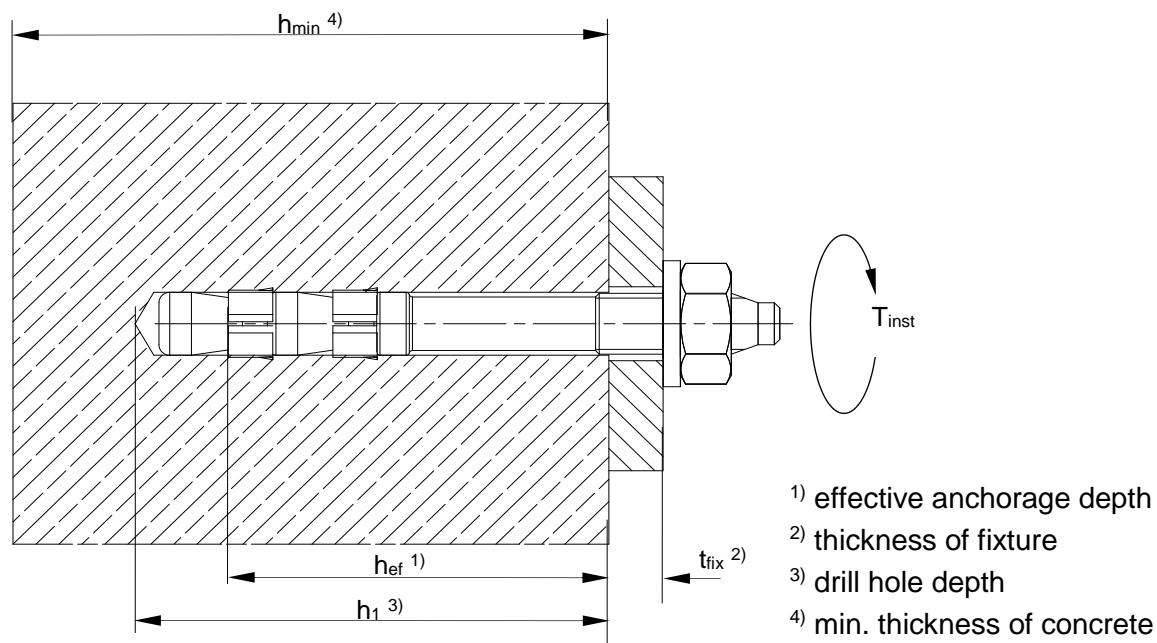

Table B2.2: Minimum spacing and minimum edge distances of anchors

Type of anchor / size		EXA M8	EXA M10	EXA M12	EXA M16	EXA M20
Minimum spacing	$s_{\text{min}} [\text{mm}]$	45	50	75	85	105
	for $c \geq [\text{mm}]$	60	85	90	145	170
Minimum edge distance	$c_{\text{min}} [\text{mm}]$	40	65	90	90	100
	for $s \geq [\text{mm}]$	100	100	75	145	170

fischer Anchor bolt EXA

Intended Use

Installation parameters, minimum spacing and edge distance

Annex B2

Appendix 6 / 9

Installation instructions:

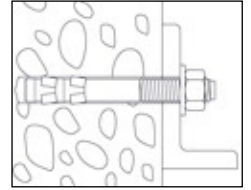
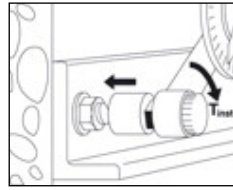
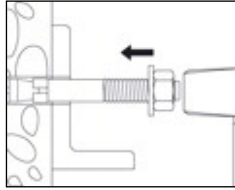
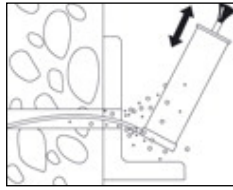
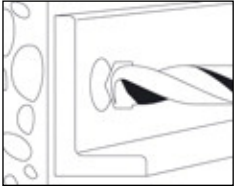

fischer Anchor bolt EXA

Intended Use

Installation instructions

Annex B3

Appendix 7 / 9

Table C1.1: Characteristic resistance to tension and shear load

			EXA M8	EXA M10	EXA M12	EXA M16	EXA M20
Steel failure							
Characteristic Resistance in tension	$N_{Rk,s}$	[kN]	23	35	48	62	108
Partial safety factor	$\gamma_{Ms,N}^{1)}$	[-]	1,48	1,44	1,40	1,57	1,57
Characteristic resistance in shear without lever arm	$V_{Rk,s}$	[kN]	13	19	23 ²⁾	51 ²⁾	75 ²⁾
Partial safety factor	$\gamma_{Ms,V}^{1)}$	[-]	1,50	1,50	1,50	1,31	1,31
k ₇ Factor	k ₇	[-]	1,0	1,0	1,0	1,0	1,0
Characteristic resistance in bending	$M^0_{Rk,s}$	[Nm]	27	50	85	183	357
Pullout failure							
Characteristic resistance in uncracked concrete C20/25	$N_{Rk,p}$	[kN]	12	16	25	35	52
Increasing factor for N_{Rk}	C25/30	Ψ_c	[-]	1,10			
	C30/37		[-]	1,22			
	C35/45		[-]	1,34			
	C40/50		[-]	1,41			
	C45/55		[-]	1,48			
	C50/60		[-]	1,55			
Concrete cone failure and splitting failure							
Effective embedment depth	h_{ef}	[mm]	47	49	67	85	103
Factor uncracked concrete	$k_{ucr,N}$	[-]	10,1				
Installation safety factor	$\gamma_2 = \gamma_{Inst}$		1,0				
Increasing factor for N_{Rk}	C30/37	Ψ_c	[-]	1,22		1,12	1,00
	C40/50		[-]	1,41		1,23	1,00
	C50/60		[-]	1,55		1,30	1,00
Characteristic spacing concrete cone failure	$s_{cr,N}$	[mm]	140	150	200	260	310
Characteristic spacing splitting failure	$s_{cr,sp}$	[mm]	330	340	425	425	515
Characteristic edge distance concrete cone failure	$c_{cr,N}$	[mm]	70	75	100	130	155
Characteristic edge distance splitting failure	$c_{cr,sp}$	[mm]	165	170	215	215	260
Concrete pryout failure							
k ₈ factor	k ₈	[-]	1,0	1,0	2,0	2,0	2,0
Concrete edge failure							
Effective length of anchor	$l_f = h_{ef}$	[mm]	47	49	67	85	103
Outside diameter of anchor	d_{nom}	[mm]	8	10	12	16	20

¹⁾ In absence of other national regulations

²⁾ Values issued from the test series because the failure does not occur in the threaded part.

fischer Anchor bolt EXA

Performances

Characteristic Resistances of tension and shear load

Annex C1

Appendix 8 / 9

Table C2.1: Displacements under tension loads

		EXA M8	EXA M10	EXA M12	EXA M16	EXA M20
Tension load in uncracked concrete C20/25 to C50/60 [kN]		3,4	5,3	8,3	13,9	20,6
Displacement	δ_{N0} [mm]	0,1	0,1	0,1	0,2	0,3
	$\delta_{N\infty}$ [mm]	0,3	0,3	0,3	0,3	0,6

Table C2.2: Displacements under shear loads

		EXA M8	EXA M10	EXA M12	EXA M16	EXA M20
Shear load in uncracked concrete C20/25 to C50/60 [kN]		6,2	9,1	11,0	27,8	40,9
Displacement	δ_{V0} [mm]	2,7 ¹⁾	4,5 ¹⁾	2,5 ¹⁾	3,2 ¹⁾	5,5 ¹⁾
	$\delta_{V\infty}$ [mm]	3,8 ¹⁾	6,1 ¹⁾	3,1 ¹⁾	4,3 ¹⁾	7,6 ¹⁾

¹⁾ All values including axial clearance from anchor and attachment part.

Displacement under shear loading: additional displacements due to through hole in the fixture shall be considered

fischer Anchor bolt EXA

Performances
Displacements

Annex C2

Appendix 9 / 9