

PROHLÁŠENÍ O VLASTNOSTECH

DoP 0344

pro svorníková kotva fischer ULTRACUT FBS II R (Kovové kotvy do betonu)

CS

1. Jedinečný identifikační kód typu výrobku: **DoP 0344**
2. Zamýšlené/zamýšlená použití: **Dodatečné upevnění v tažené a tlačené zóně betonu, viz. dodatek, obzvláště Přílohy B1 - B5.**
3. Výrobce: **fischerwerke GmbH & Co. KG, Klaus-Fischer-Str. 1, 72178 Waldachtal, Německo**
4. Zplnomocněný zástupce: **-**
5. Systém/systémy POSV: **1**
6. Evropský dokument pro posuzování: **EAD 330232-01-0601**
Evropské technické posouzení: **ETA-17/0740; 2022-03-08**
Subjekt pro technické posuzování: **DIBt- Deutsches Institut für Bautechnik**
Oznámený subjekt/oznámené subjekty: **2873 TU Darmstadt**

7. Deklarovaná vlastnost/Deklarované vlastnosti:

Mechanická odolnost a stabilita (BWR 1)

Charakteristická únosnost v tahu (pro statickou a kvazistatickou akci) Metoda A:

- 1 Odolnost proti selhání oceli: Přílohy C1
- 2 Odolnost proti selhání vytažením: Přílohy C1
- 3 Odolnost proti selhání betonu: Přílohy C1
- 4 Pevnost: Přílohy C1
- 5 Minimální vzdálenost od okraje a rozteč: Přílohy B3
- 6 Okrajová vzdálenost bránící rozštěpení při zatížení: Přílohy C1

Charakteristická únosnost ve smyku (pro statickou a kvazistatickou akci):

- 7 Odolnost proti selhání oceli (smykové zatížení): Přílohy C1
- 8 Odolnost proti selhání rozštěpením: Přílohy C1

Charakteristická odolnost pro zjednodušený design:

- 9 Metoda B: NPD
- 10 Metoda C: NPD

Posuny:

- 11 Posuny při statickém a kvazistatickém zatížení: Přílohy C4

Charakteristická únosnost a posuny pro seismické kategorie C1 a C2:

- 12 Odolnost proti tahovému zatížení, posuny, kategorie C1: Příloha C2
Odolnost proti tahovému zatížení, posuny, kategorie C2: Příloha C2
- 13 Odolnost proti smykovému zatížení, posuny, kategorie C1: Příloha C2
Odolnost proti smykovému zatížení, posuny, kategorie C2: Příloha C2
- 14 Koefficient prstencové mezery: Příloha C2

Bezpečnost v případě požáru (BWR 2)

- 15 Reakce na oheň: Třída (A1)

Odolnost proti požáru:

- 16 Požární odolnost proti selhání oceli (tahové zatížení): Příloha C3
- 17 Požární odolnost proti selhání vytažením (tahové zatížení): Příloha C3
- 18 Požární odolnost proti selhání oceli (smykové zatížení): Příloha C3

Životnost:

- 19 Životnost: Přílohy B1

8. Příslušná technická dokumentace a/nebo specifická technická dokumentace: **-**

Vlastnosti výše uvedeného výrobku jsou ve shodě se souborem deklarovaných vlastností. Toto prohlášení o vlastnostech se v souladu s nařízením (EU) č. 305/2011 vydává na výhradní odpovědnost výrobce uvedeného výše.

Podepsáno za výrobce a jeho jménem:



Dr.-Ing. Oliver Geibig, Výkonný ředitel pro obchodní jednotky a inženýrství
Tumlingen, 2024-02-16



Jürgen Grün, Výkonný ředitel pro chemii a kvalitu

Toto PoV bylo připraveno v různých jazykových mutacích. V případě rozporu vždy rozhoduje interpretace verze v anglickém jazyce.

Příloha obsahuje nepovinné a doplňkové informace v anglickém jazyce nad rámec zákonných požadavků.

Translation guidance Essential Characteristics and Performance Parameters for Annexes

Pokyny pro překlad Základní charakteristiky a výkonnostní parametry příloh

Mechanical resistance and stability (BWR 1)		
Mechanická odolnost a stabilita (BWR 1)		
Characteristic resistance to tension load (static and quasi-static loading) Method A: Charakteristická únosnost v tahu (pro statickou a kvazistatickou akci) Metoda A:		
1	Resistance to steel failure: Odolnost proti selhání oceli:	$N_{Rk,s}$ [kN]
2	Resistance to pull-out failure: Odolnost proti selhání vytažením:	$N_{Rk,p}$ [kN], ψ_c [-]
3	Resistance to concrete cone failure: Odolnost proti selhání betonu:	$k_{cr,N}$, $k_{ucr,N}$ [-], h_{ef} , $c_{cr,N}$ [mm]
4	Robustness: Pevnost:	γ_{inst} [-]
5	Minimum edge distance and spacing: Minimální vzdálenost od okraje a rozteč:	c_{min} , s_{min} , h_{min} [mm]
6	Edge distance to prevent splitting under load: Okrajová vzdálenost bránící rozštěpení při zatížení:	$N_{Rk,sp}^0$ [kN], $c_{cr,sp}$ [mm]
Characteristic resistance to shear load (static and quasi-static loading): Charakteristická únosnost ve smyku (pro statickou a kvazistatickou akci):		
7	Resistance to steel failure (shear load): Odolnost proti selhání oceli (smykové zatížení):	$V_{Rk,s}^0$ [kN], $M_{Rk,s}^0$ [Nm], k_7 [-]
8	Resistance to pry-out failure: Odolnost proti selhání rozštěpením:	k_8 [-]
Characteristic Resistance for simplified design: Charakteristická odolnost pro zjednodušený design:		
9	Method B: Metoda B:	F_{Rk}^0 [kN], $M_{Rk,s}^0$ [Nm], ψ_c [-], c_{cr} , s_{cr} , s_{min} , c_{min} , h_{min} [mm]
10	Method C: Metoda C:	F_{Rk} [kN], $M_{Rk,s}^0$ [Nm], c_{cr} , s_{cr} , s_{min} , h_{min} [mm]
Displacements: Posuny:		
9	Displacements under static and quasi-static loading: Posuny při statickém a kvazistatickém zatížení:	δ_{N0} , $\delta_{N\infty}$, δ_{V0} , $\delta_{V\infty}$ [mm]
Characteristic resistance and displacements for seismic performance categories C1 and C2: Charakteristická únosnost a posuny pro seismické kategorie C1 a C2:		
12	Resistance to tension load, displacements, category C1: Odolnost proti tahovému zatížení, posuny, kategorie C1:	$N_{Rk,s,C1}$, $N_{Rk,p,C1}$ [kN]
	Resistance to tension load, displacements, category C2: Odolnost proti tahovému zatížení, posuny, kategorie C2:	$N_{Rk,s,C2}$, $N_{Rk,p,C2}$ [kN], $\delta_{N,C2}$ [mm]
13	Resistance to shear load, displacements, category C1: Odolnost proti smykovému zatížení, posuny, kategorie C1:	$V_{Rk,s,C1}$ [kN]
	Resistance to shear load, displacements, category C2: Odolnost proti smykovému zatížení, posuny, kategorie C2:	$V_{Rk,s,C2}$ [kN], $\delta_{V,C2}$ [mm]
14	Factor for annular gap: Koeficient prstencové mezery:	α_{gap} [-]
Safety in case of fire (BWR 2)		
Bezpečnost v případě požáru (BWR 2)		
15	Reaction to fire: Reakce na oheň:	Class
Resistance to fire: Odolnost proti požáru:		
16	Fire resistance to steel failure (tension load): Požární odolnost proti selhání oceli (tahové zatížení):	$N_{Rk,s,fi}$ [kN]
17	Fire resistance to pull-out failure (tension load): Požární odolnost proti selhání vytažením (tahové zatížení):	$N_{Rk,p,fi}$ [kN]
18	Fire resistance to steel failure (shear load): Požární odolnost proti selhání oceli (smykové zatížení):	$V_{Rk,s,fi}$ [kN], $M_{Rk,s,fi}^0$ [Nm]
Durability: Životnost:		
19	Durability: Životnost:	Description/Level

II SPECIFIC PART OF THE EUROPEAN TECHNICAL ASSESSMENT

1 Technical description of product and intended use

Technical description of the product

fischer concrete screw UltraCut FBS II R is a concrete screw made of stainless steel. The anchor is installed in a drilled hole and anchored by mechanical interlock.

An illustration of the product is given in Annex A.

The characteristic material values, dimensions and tolerances of the anchors not indicated in Annexes shall correspond to the respective values laid down in the technical documentation of this European Technical Assessment.

The anchors are intended to be used with embedment depth given in Annex B, Table B2.1. The intended use specifications of the product are detailed in the Annex B1.

2 Specification of the intended use in accordance with the applicable European Assessment Document (hereinafter EAD)

The performances given in Section 3 are only valid if the anchor is used in compliance with the specifications and conditions given in Annex B.

The provisions made in this European Technical Assessment are based on an assumed intended working life of the anchor of 50 years.

The indications given on the working life cannot be interpreted as a guarantee given by the producer or Assessment Body, but are to be regarded only as a means for choosing the right products in relation to the expected economically reasonable working life of the works.

3 Performance of the product and references to the methods used for its assessment

3.1 Characteristics of product

Mechanical resistance and stability (BWR 1):

The essential characteristics are detailed in the Annex C1, C2 and C4.

Safety in case of fire (BWR 2):

The essential characteristics are detailed in the Annex C3.

Other Basic Requirements are not relevant.

3.2 Methods of assessment

The assessment of fitness of the anchor for the intended use in relation to the requirements for mechanical resistance and stability and safety in use in the sense of the Basic Works Requirement 1 has been made in accordance with EAD 330232-01-0601; Mechanical fasteners for use in concrete.

4 Assessment and verification of constancy of performance (AVCP)

4.1 AVCP system

According to the decision 1996/582/EC of the European Commission, the system(s) of assessment and verification of constancy of performance (see Annex V to Regulation (EU) No. 305/2011) is 1.

Product in the installed condition

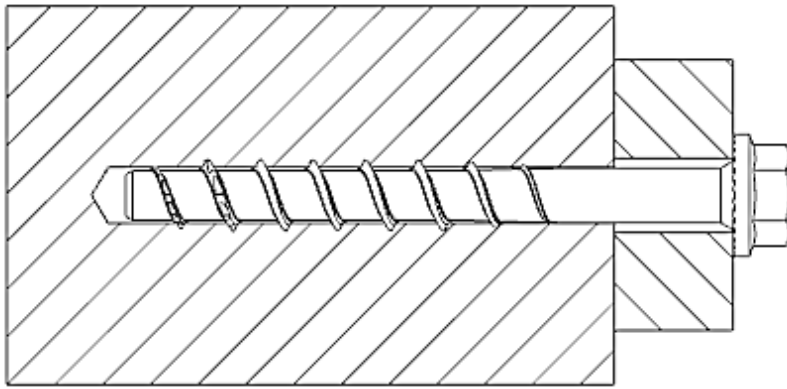

FBS II US R /
FBS II US TX R

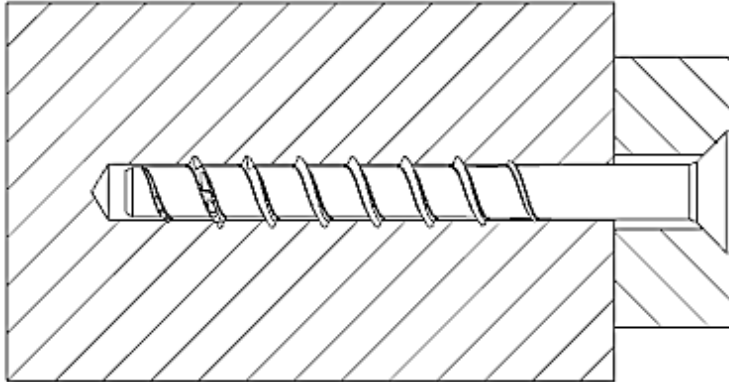

FBS II SK R

(Fig. not to scale)





fischer concrete screw UltraCut FBS II R

Product description
Product in the installed condition

Annex A1
of European
Technical Assessment
ETA-17/0740

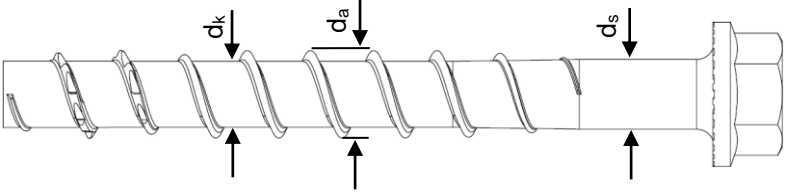
Table A2.1: Geometry and material

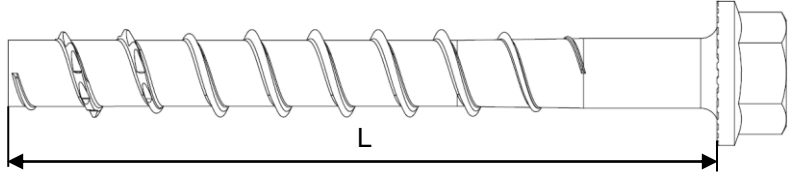
Type of screw / size		FBS II US R / SK R			
		8	10	12	
Thread outer diameter	d_a	[mm]	10,3	12,5	14,6
Core diameter	d_k		7,5	9,4	11,1
Shaft diameter	d_s		8,0	9,9	11,7
Material		Tip: hardened steel; Shaft and head: stainless steel			

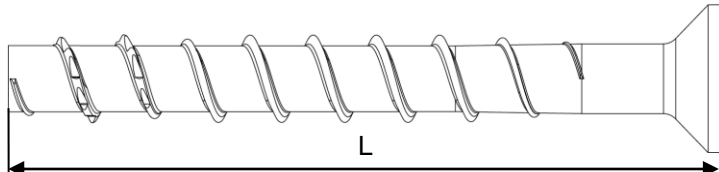
Hexagon head with formed washer (US)		
Hexagon head with formed washer and TX-drive (US TX)		
Countersunk Head (SK)		

Head Marking

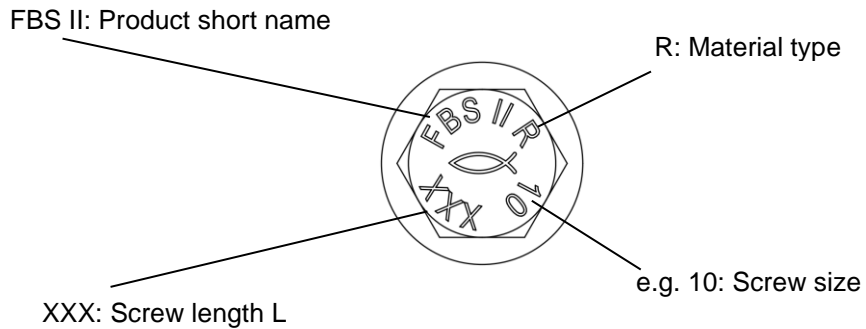

(Fig. not to scale)

fischer concrete screw UltraCut FBS II R	Annex A2 of European Technical Assessment ETA-17/0740
Product description Geometry and material	

Specification of intended use:

Size	FBS II R							
	8		10			12		
Nominal embedment depth [mm]	50	65	55	65	85	60	75	100
Static and quasi-static loads in cracked and uncracked concrete	✓							
Fire exposure								
Seismic performance category C1 and C2	-	✓	-	✓	-	✓	-	✓

Base materials:

- Compacted reinforced or unreinforced normal weight concrete without fibres (cracked and uncracked) according to EN 206:2013 + A1:2016
- Strength classes C20/25 to C50/60 according to EN 206:2013 + A1:2016

Use conditions (Environmental conditions):

- Structures subjected to dry internal conditions
- For all other conditions according to EN 1993-1-4:2015-10, corresponding to corrosion resistance class CRC III

Design:

- Anchorages are to be designed under the responsibility of an engineer experienced in anchorages and concrete work.
- Verifiable calculation notes and drawings are to be prepared taking account of the loads to be anchored. The position of the screw is indicated on the design drawings (e.g. position of the screw relative to reinforcement or to supports, etc.).
- Design of fastenings according to EN 1992-4:2016 and EOTA Technical Report TR 055

Installation:

- Hammer drilling or diamond drilling or hollow drilling according to Annex B4
- Screw installation carried out by appropriately qualified personnel and under the supervision of the person responsible for technical matters on site.
- In case of aborted hole: New hole must be drilled at a minimum distance of twice the depth of the aborted hole or closer, if the hole is filled with a high strength mortar and only if the hole is not in the direction of the oblique tensile or shear load.
- Adjustability according to Annex B3
- Cleaning of drill hole is not necessary when using a hollow drill or:
 - If drilling vertically upwards
 - If drilling vertical downwards and the drill hole depth has been increased. It is recommended to increase the drill depth with additional $3 d_0$.
- After correct installation further turning of the screw head should not be possible.
- The head of the screw must be fully engaged on the fixture and show no signs of damage.
- For seismic performance category C2 applications: The gap between screw shaft and fixture must be filled with mortar; mortar compressive strength $\geq 50 \text{ N/mm}^2$. (e.g. FIS V Plus, FIS HB, FIS SB or FIS EM Plus)

fischer concrete screw UltraCut FBS II R

Intended use
Specification

Annex B1

of European
Technical Assessment
ETA-17/0740

Table B2.1: Installation parameters

FBS II R		8		10			12			
Nominal embedment depth	h_{nom}	50	65	55	65	85	60	75	100	
Nominal drill hole diameter	d_0	8		10			12			
Cutting diameter of drill bits		8,45		10,45			12,50			
Cutting diameter for diamond drillers	$d_{cut} \leq$	8,10		10,30			12,30			
Clearance hole diameter	d_f	10,6 – 12,0		12,8 – 14,0			14,8 – 16,0			
Wrench size (US,S)	SW	13		15			17			
Tx-size	Tx	[-]		40			50			
Countersunk head diameter	d_h	18		21			-			
Countersunk diameter in fixture	d_c	20		23						
Drill hole depth		60	75	65	75	95	70	85	110	
Drill hole depth (with adjustable setting)	$h_1 \geq$	70	85	75	85	105	80	95	120	
Thickness of fixture	$t_{fix} \leq$	L - h_{nom}								
Length of screw	$L_{min} =$	50	65	55	65	85	60	75	100	
	$L_{max} =$	400	415	405	415	435	410	425	450	
Torque impact screw driver	$T_{imp,max}$	450					650			
Torque impact screw driver (with adjustable setting process)	$T_{imp,max}$	300					450			

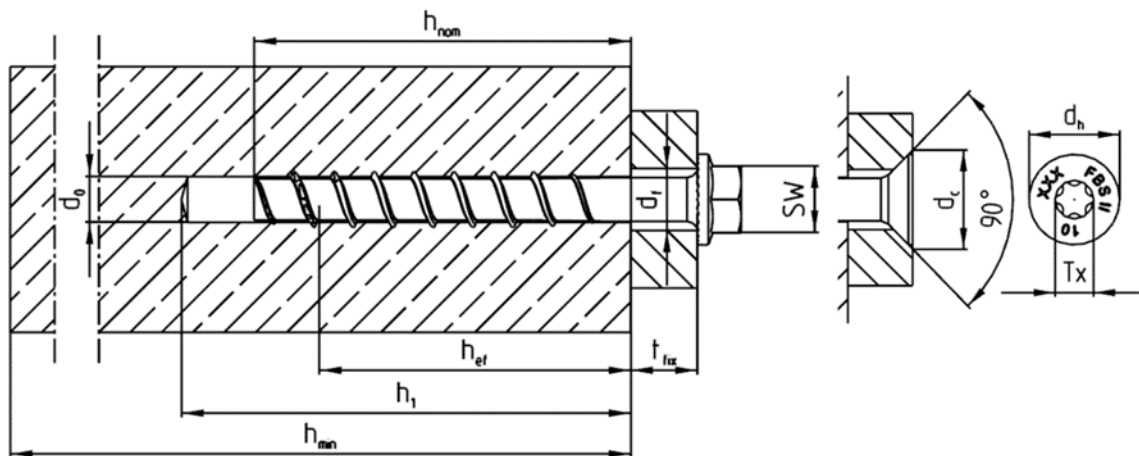

(Fig. not to scale)

fischer concrete screw UltraCut FBS II R

Intended use
Installation parameters

Annex B2
of European
Technical Assessment
ETA-17/0740

Adjustment

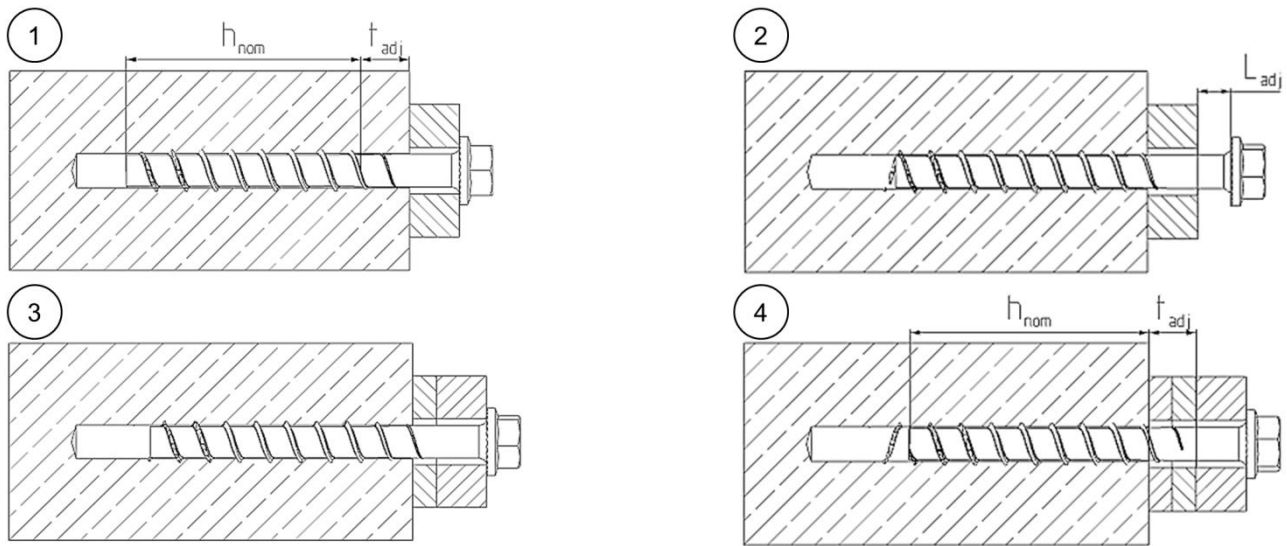

It is permissible to untighten the screw up to two times for adjustment purposes. Therefore the screw may be untightened to a maximum of $L_{adj} = 20$ mm to the surface of the initial fixture. The total permissible thickness of shims added during the adjustment process is $t_{adj} = 10$ mm. The required nominal anchoring depth h_{nom} must be kept after the adjustment process.

(Fig. not to scale)

Table B3.1: Minimum thickness of concrete members, minimum spacing and edge distance

FBS II R		8		10			12			
Nominal embedment depth	h_{nom}	[mm]	50	65	55	65	85	60	75	100
Minimum thickness of concrete member	h_{min}		100	120	100	120	140	110	130	150
Minimum spacing	s_{min}		35		40			50		
Minimum edge distance	c_{min}		35		40			50		

fischer concrete screw UltraCut FBS II R

Intended use – Adjustment
Minimum thickness of members, minimum spacing and edge distance

Annex B3
of European
Technical Assessment
ETA-17/0740

Installation instruction part 1

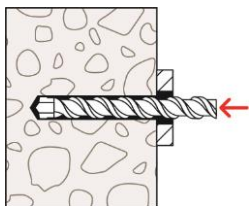

Step 1: Creation of the drill hole:

Drill the hole using hammer drill, hollow drill or diamond core drill

Drill hole diameter d_0 and drill hole depth h_1 according to table B2.1

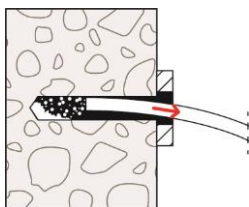

Step 2: Cleaning of the drill hole - horizontal:

Clean the drill hole. This step can be omitted in the preparation of the hole by using a hollow drill bit or diamond core drill. (recommendation: use the fischer FHD hollow drill bit)

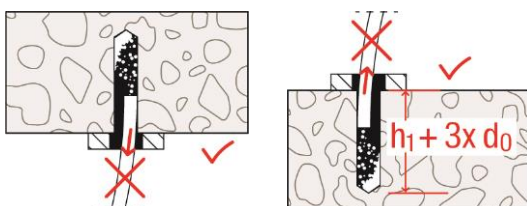

Step 2: Cleaning of the drill hole - vertical:

Cleaning of the drill hole can be omitted, if drilling vertically upwards or if drilling vertically downwards and the hole depth has been increased. It is recommended to increase the drill hole depth by an additional $3 \times$ drilling \varnothing when drilling vertically downwards.

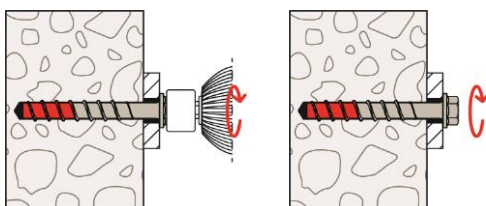

Step 3: Installation:

Turn in until the head is in contact with the fixture.

Installation with any torque impact screw driver up to the maximum mentioned torque moment ($T_{imp,max}$ according to table B2.1).

(recommendation: use the fischer FSS 18V 400BL)

Alternatively, all other tools without an indicated torque moment are allowed (e.g. ratchet spanner). The indicated torque moments $T_{imp,max}$ for impact screw driver are not decisive for manual installation.

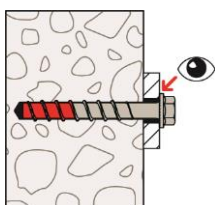

Step 4: Checking of the correct installation:

After installation a further turning of the screw must not be possible. The head of the screw must be in contact with the fixture and is not damaged

fischer concrete screw UltraCut FBS II R

Installation Instructions

Annex B4
of European
Technical Assessment
ETA-17/0740

Installation instruction part 2

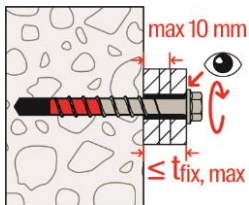
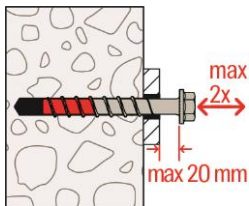
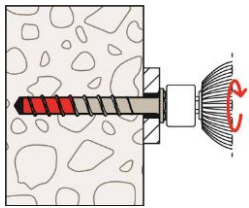

Adjustment

Optional:

It is permissible to adjust the screw twice.

Therefore, the screw may be untightened to a maximum of $L_{adj} = 20$ mm off the surface of the initial fixture. The total permissible thickness of shims added during the adjustment process

is $t_{adj} = 10$ mm.

The required nominal anchoring depth h_{nom} must be kept after the adjustment process. (see also annex B3)

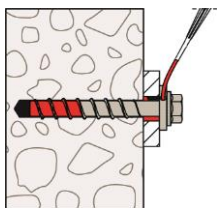

Filling of the annular gap

For seismic performance category C2 applications:

The gap between screw shaft and fixture must be filled with mortar; mortar compressive strength ≥ 50 N/mm² (e. g. FIS V Plus, FIS HB, FIS SB or FIS EM Plus).

As an aid for filling the gap, the filling disc FFD is recommended.

fischer concrete screw UltraCut FBS II R

Installation Instructions

Annex B5
of European
Technical Assessment
ETA-17/0740

Table C1.1: Characteristic values for static and quasi-static action

FBS II R			8		10			12			
Nominal embedment depth	h_{nom}	[mm]	50	65	55	65	85	60	75	100	
Steel failure for tension load and shear load											
Characteristic resistance	$N_{Rk,s}$	[kN]	27,8		43,8			67,7			
Partial factor	$\gamma_{Ms,N}$	-	1,5								
Characteristic resistance	$V^0_{Rk,s}$	[kN]	18,0	27,8	13,2	19,3	36,6	20,4	40,1	45,8	
Partial factor	$\gamma_{Ms,V}$	-	1,25								
Factor for ductility	k_7	[-]	1,0								
Characteristic bending resistance	$M^0_{Rk,s}$	[Nm]	31,3		68,5			112,8			
Pullout failure											
Charact. resistance in concrete C20/25	uncracked	$N_{Rk,p}$	[kN]	7,0	14,0	8,5	14,0	$\geq N^0_{Rk,c^{(1)}}$	10,0	12,0	$\geq N^0_{Rk,c^{(1)}}$
	cracked	$N_{Rk,p}$	[kN]	4,0	9,0	4,5	6,0	16,0	4,5	11,0	$\geq N^0_{Rk,c^{(1)}}$
Increasing factors concrete	C25/30	ψ_c	[-]	1,12							
	C30/37			1,22							
	C35/45			1,32							
	C40/50			1,41							
	C45/55			1,50							
	C50/60			1,58							
Installation factor	γ_{inst}	[-]	1,0								
Concrete cone failure and splitting failure; concrete pryout failure											
Effective embedment depth	h_{ef}	[mm]	40	52	43	51	68	47	60	81	
Factor for uncracked concrete	$k_{ucr,N}$	[-]	11,0								
Factor for cracked concrete	$k_{cr,N}$		7,7								
Characteristic edge distance	$c_{cr,N}$	[mm]	$1,5 h_{ef}$								
Characteristic spacing	$s_{cr,N}$		$3 h_{ef}$								
Char. resistance for splitting	$N^0_{Rk,Sp}$	[kN]	12,0	18,4	13,0	17,9	$\geq N^0_{Rk,c^{(1)}}$	15,8	22,9	$\geq N^0_{Rk,c^{(1)}}$	
Char. edge distance for splitting	$c_{cr,sp}$	[mm]	$1,5 h_{ef}$								
Char. spacing for splitting	$s_{cr,sp}$		$3 h_{ef}$								
Factor for pryout failure	k_8	[-]	1,0				2,0	1,0	2,0		
Installation factor	γ_{inst}		1,0								
Concrete edge failure											
Effective length in concrete	$l_f = h_{nom}$	[mm]	50	65	55	65	85	60	75	100	
Nominal diameter of screw	d_{nom}		8		10			12			
Adjustment											
Maximum thickness of shims	t_{adj}	[mm]	10								
Max. number of adjustments	n_a		2								

¹⁾ $N^0_{Rk,c}$ according EN 1992-4:2018

fischer concrete screw UltraCut FBS II R

Characteristic values for static and quasi-static action

Annex C1
of European
Technical Assessment
ETA-17/0740

Table C2.1: Characteristic values for Seismic Performance Category C1

FBS II R			8	10	12	
Nominal embedment depth	h_{nom}	[mm]	65	85	100	
Steel failure for tension load and shear load C1						
Characteristic resistance	$N_{Rk,s,C1}$	[kN]	27,8	43,8	67,7	
	$V_{Rk,s,C1}$		18,1	29,3	36,6	
Without filling of the annular gap ¹⁾	α_{gap}	[-]	0,5			
With filling of the annular gap ¹⁾			1,0			
Pullout failure						
Characteristic resistance in cracked concrete	$N_{Rk,p,C1}$	[kN]	9,0	16,0	$\geq N^0_{Rk,c}$ ²⁾	
Concrete cone failure						
Effective embedment depth	h_{ef}	[mm]	52	68	81	
Concrete cone failure	Edge distance		$C_{cr,N}$	$1,5 h_{ef}$		
	Spacing		$S_{cr,N}$	$3 h_{ef}$		
Installation factor	γ_{inst}	[-]	1,0			
Concrete pryout failure						
Factor for pryout failure	k_8	[-]	1,0	2,0		
Concrete edge failure						
Effective length in concrete	$l_f = h_{nom}$	[mm]	65	85	100	
Nominal diameter of screw	d_{nom}		8	10	12	

¹⁾ Filling of the annular gap according annex B 5 ²⁾ $N^0_{Rk,c}$ according EN 1992-4:2018

Table C2.2: Characteristic values for Seismic Performance Category C2

FBS II R			8	10	12	
Nominal embedment depth	h_{nom}	[mm]	65	85	100	
Steel failure for tension load and shear load C2						
Characteristic resistance	$N_{Rk,s,C2}$	[kN]	27,8	43,8	67,7	
	$V_{Rk,s,C2}$		9,7	8,8	19,7	
With filling of the annular gap ¹⁾	α_{gap}	[-]	1,0			
Pullout failure						
Characteristic resistance in cracked concrete	$N_{Rk,p,C2}$	[kN]	2,8	5,0	7,3	
Concrete cone failure						
Effective embedment depth	h_{ef}	[mm]	52	68	81	
Concrete cone failure	Edge distance		$C_{cr,N}$	$1,5 h_{ef}$		
	Spacing		$S_{cr,N}$	$3 h_{ef}$		
Installation factor	γ_{inst}	[-]	1,0			
Concrete pryout failure						
Factor for pryout failure	k_8	[-]	1,0	2,0		
Concrete edge failure						
Effective length in concrete	$l_f = h_{nom}$	[mm]	65	85	100	
Nominal diameter of screw	d_{nom}		8	10	12	

¹⁾ Filling of the annular gap according annex B 5. Application without filling of the annular gap not allowed.

fischer concrete screw UltraCut FBS II R

Characteristic values for Seismic Performance Category C1 and C2

Annex C2
of European
Technical Assessment
ETA-17/0740

Table C3.1: Characteristic values for resistance to fire

FBS II R			8		10			12			
Nominal embedment depth	h_{nom}	[mm]	50	65	55	65	85	60	75	100	
Steel failure for tension load and shear load ($F_{Rk,s,fi} = N_{Rk,s,fi} = V_{Rk,s,fi}$)											
Characteristic resistance for the head shapes	US, US TX	$F_{Rk,s,fi}$	R30	[kN]	2,3	6,4	3,5	11,0	4,6	15,2	
			R60		1,8	4,7	2,7	8,1	3,7	11,2	
			R90		1,3	2,9	2,0	5,2	2,7	7,3	
			R120		1,0	2,0	1,6	3,8	2,2	5,3	
	SK	$F_{Rk,s,fi}$	R30	[kN]	2,1		3,0		No performance declared		
			R60		1,7		2,3				
			R90		1,2		1,6				
			R120		1,0		1,2				
	US, US TX	$M^0_{Rk,s,fi}$	R30	[Nm]	2,6	7,2	7,6	15,4	16,8	25,3	
			R60		2,0	5,2	6,0	11,4	13,3	18,7	
			R90		1,5	3,3	4,4	7,3	9,8	12,1	
			R120		1,2	2,3	3,6	5,3	8,0	8,8	
	SK	$M^0_{Rk,s,fi}$	R30	[Nm]	2,4		4,2		No performance declared		
			R60		1,9		3,2				
			R90		1,4		2,2				
			R120		1,1		1,7				
Pullout failure											
Characteristic resistance	$N_{Rk,p,fi}$	R30	[kN]	1,7	2,4	2,1	3,5	4,3	2,5	3,0	6,3
		R60									
		R90									
		R120									
Concrete cone failure											
Characteristic resistance	$N_{Rk,c,fi}$	R30	[kN]	1,6	3,4	2,1	3,2	6,6	2,6	4,8	10,2
		R60									
		R90									
		R120									
Edge distance											
R30 to R120	$C_{cr,fi}$	[mm]	2 h_{ef}								
In case of fire attack from more than one side, the minimum edge distance shall be ≥ 300 mm											
Spacing											
R30 to R120	$S_{cr,fi}$	[mm]	2 $C_{cr,fi}$								
Concrete pryout failure											
R30 to R120	k_8	[-]	1,0				2,0	1,0	2,0		
The anchorage depth has to be increased for wet concrete by at least 30 mm compared to the given value.											
fischer concrete screw UltraCut FBS II R								Annex C3 of European Technical Assessment ETA-17/0740			
Characteristic values for resistance to fire											

Table C4.1: Displacements due to tension loads (static and quasi-static)

FBS II R			8		10			12		
Nominal embedment depth	h_{nom}	[mm]	50	65	55	65	85	60	75	100
Tension load in uncracked concrete	N	[kN]	3,5	7,1	4,2	7,0	11,9	5,0	6,0	17,1
Displacement in uncracked concrete	δ_{N0}	[mm]	0,5	0,7	0,4	0,6	0,8	1,0	0,9	1,25
	$\delta_{N\infty}$		0,7	0,7	0,8	0,8	0,8	1,25	1,25	1,25
Tension load in cracked concrete	N	[kN]	3,5	4,5	4,2	7,0	8,1	5,0	6,0	12,0
Displacement in cracked concrete	δ_{N0}	[mm]	0,6	0,4	0,4	0,6	0,7	0,9	0,9	1,4
	$\delta_{N\infty}$		1,5	1,1	1,0	1,8	1,8	1,4	1,7	1,9

Table C4.2: Displacements due to shear loads (static and quasi-static)

FBS II R			8		10			12		
Nominal embedment depth	h_{nom}	[mm]	50	65	55	65	85	60	75	100
Shear load in cracked and uncracked concrete	V	[kN]	11,0	15,9	10,4	11,9	20,9	12,7	24,9	26,2
Displacement (the gap between fastener and fixture is subtracted)	δ_{V0}	[mm]	4,1	2,7	1,2	1,2	3,5	1,1	2,5	2,9
	$\delta_{V\infty}$		6,2	4,1	1,8	1,8	5,3	1,7	3,8	4,4

Table C4.3: Displacements due to tension loads (Seismic Performance Category C2)

FBS II R			8	10	12
Nominal embedment depth	h_{nom}		65	85	100
Displacement DLS	$\delta_{N,C2 (DLS)}$	[mm]	0,9	0,9	1,1
Displacement ULS	$\delta_{N,C2 (ULS)}$		2,5	2,7	3,2

Table C4.4: Displacements due to shear loads (Seismic Performance Category C2)

FBS II R			8	10	12
Nominal embedment depth	h_{nom}		65	85	100
Displacement DLS	$\delta_{V,C2 (DLS)}$	[mm]	1,6	1,7	2,6
Displacement ULS	$\delta_{V,C2 (ULS)}$		5,0	3,8	6,6

fischer concrete screw UltraCut FBS II R

Displacements due to tension and shear loads

Annex C4
of European
Technical Assessment
ETA-17/0740