

PROHLÁŠENÍ O VLASTNOSTECH

DoP 0410

pro injektážní systém fischer FIS SB (malta pro dodatečné vleповání výztuže)

CS

1. Jedinečný identifikační kód typu výrobku: **DoP 0410**
2. Zamýšlené/zamýšlená použití: **Systém pro dodatečné vleповání výztuže do betonu, Viz. dodatek, obzvláště Přílohy B1-B11.**
3. Výrobce: **fischerwerke GmbH & Co. KG, Otto-Hahn-Straße 15, 79211 Denzlingen, Německo**
4. Zplnomocněný zástupce: **-**
5. Systém/systémy POSV: **1**
6. Evropský dokument pro posuzování: **EAD 330087-01-0601 Edition 06/2021**
Evropské technické posouzení: **ETA-13/0651; 2025-12-16**
Subjekt pro technické posuzování: **DIBt- Deutsches Institut für Bautechnik**
Oznámený subjekt/oznámené subjekty: **2873 TU Darmstadt**
7. Deklarovaná vlastnost/Deklarované vlastnosti:
Mechanická odolnost a stabilita (BWR 1)
Charakteristická odolnost při statickém a kvazistatickém zatížení:
Pevnost spoje dodatečně vleповané výztuže: Příloha C1
Redukční faktor: Příloha C1
Zvětšující faktor pro minimální kotevní délku: Příloha C1
Charakteristická odolnost proti selhání oceli pro tažené roxorové kotvy: Příloha C2

Charakteristická odolnost při seismickém zatížení:
Pevnost spoje při seismickém zatížení, Faktor účinnosti seismického spoje: NPD
Minimální krytí betonem při seismickém zatížení: NPD

Bezpečnost v případě požáru (BWR 2)
Odolnost proti ohni: Třídy (A1)

Požární odolnost:
Pevnost spoje při zvýšené teplotě pro dodatečně vleповanou výztuž hodnocená po dobu 50 let: NPD
Pevnost spoje při zvýšené teplotě pro dodatečně vleповanou výztuž hodnocená po dobu 100 let: NPD
Charakteristická odolnost proti selhání oceli pro tažené roxorové kotvy při vystavení ohni: NPD
8. Příslušná technická dokumentace a/nebo specifická technická dokumentace: **-**

Vlastnosti výše uvedeného výrobku jsou ve shodě se souborem deklarováných vlastností. Toto prohlášení o vlastnostech se v souladu s nařízením (EU) č. 305/2011 vydává na výhradní odpovědnost výrobce uvedeného výše.

Podepsáno za výrobce a jeho jménem:

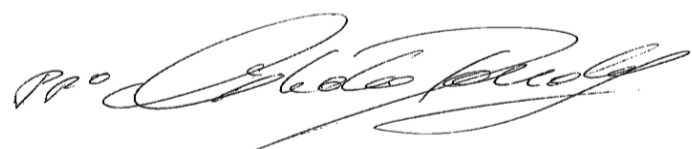

Dr. Ronald Mihala, Výkonný ředitel pro obchodní jednotky a inženýrství
Tumlingen, 2026-01-05



Dieter Pfaff, Vedoucí Mezinárodní produkční federace a řízení kvality

Toto PoV bylo připraveno v různých jazykových mutacích. V případě rozporu vždy rozhoduje interpretace verze v anglickém jazyce. Příloha obsahuje nepovinné a doplňkové informace v anglickém jazyce nad rámec zákonných požadavků.

Translation guidance Essential Characteristics and Performance Parameters for Annexes

Pokyny pro překlad Základní charakteristiky a výkonnostní parametry příloh

Mechanical resistance and stability (BWR 1)		
Mechanická odolnost a stabilita (BWR 1)		
Characteristic resistance under static and quasi-static loading: Charakteristická odolnost při statickém a kvazistatickém zatížení:		
1	Bond strength of post-installed rebar: Pevnost spoje dodatečně vlepané výztuže:	$f_{bd,PIR}$ [N/mm ²], $f_{bd,PIR,100y}$ [N/mm ²]
2	Bond efficiency factor: Redukční faktor:	k_b [-], $k_{b,100y}$ [-]
3	Amplification factor for minimum anchorage length: Zvětšující faktor pro minimální kotevní délku:	α_{lb} [-], $\alpha_{lb,100y}$ [-]
4	Characteristic resistance to steel failure for rebar tension anchors: Charakteristická odolnost proti selhání oceli pro tažené roxorové kotvy:	$N_{Rk,s}$ [kN]
Characteristic resistance under seismic loading: Charakteristická odolnost při seismickém zatížení:		
5	Bond strength under seismic loading, Seismic bond efficiency factor: Pevnost spoje při seismickém zatížení, Faktor účinnosti seismického spoje:	$f_{bd,PIR,seis}$ [N/mm ²], $k_{b,seis}$ [-], $f_{bd,PIR,seis,100y}$ [N/mm ²], $k_{b,seis,100y}$ [-]
6	Minimum concrete cover under seismic loading: Minimální krytí betonem při seismickém zatížení:	$c_{min,seis}$ [mm]
Safety in case of fire (BWR 2)		
Bezpečnost v případě požáru (BWR 2)		
7	Reaction to fire: Odolnost proti ohni:	Class
Resistance to fire: Požární odolnost:		
8	Bond strength at increased temperature for post-installed rebar assessed for 50 years: Pevnost spoje při zvýšené teplotě pro dodatečně vlepanou výztuž hodnocená po dobu 50 let:	$f_{bd,fi}(\theta)$ [N/mm ²], $k_{fi}(\theta)$ [-], θ_{max} [°C]
9	Bond strength at increased temperature for post-installed rebar assessed for 100 years: Pevnost spoje při zvýšené teplotě pro dodatečně vlepanou výztuž hodnocená po dobu 100 let:	$f_{bd,fi,100y}(\theta)$ [N/mm ²], $k_{fi,100y}(\theta)$ [-], θ_{max} [°C]
10	Characteristic resistance to steel failure for rebar tension anchors under fire exposure: Charakteristická odolnost proti selhání oceli pro tažené roxorové kotvy při vystavení ohni:	$N_{Rk,s,fi}$ [kN]

Specific Part

1 Technical description of the product

The subject of this European Technical Assessment is the post-installed connection, by anchoring or overlap connection joint, of reinforcing bars (rebars) in existing structures made of normal weight concrete, using the "Rebar connection with fischer injection system FIS SB" in accordance with the regulations for reinforced concrete construction.

Reinforcing bars made of steel with a diameter ϕ from 8 to 32 mm or the fischer rebar anchor FRA or FRA HCR of sizes M12 to M24 according to Annex A and injection mortar FIS SB are used for rebar connections. The rebar is placed into a drilled hole filled with injection mortar and is anchored via the bond between rebar, injection mortar and concrete.

The product description is given in Annex A.

2 Specification of the intended use in accordance with the applicable European assessment Document

The performances given in Section 3 are only valid if the rebar connection is used in compliance with the specifications and conditions given in Annex B.

The verifications and assessment methods on which this European Technical Assessment is based lead to the assumption of a working life of the rebar connections of at least 50 years. The indications given on the working life cannot be interpreted as a guarantee given by the producer, but are to be regarded only as a means for choosing the right products in relation to the expected economically reasonable working life of the works.

3 Performance of the product and references to the methods used for its assessment

3.1 Mechanical resistance and stability (BWR 1)

Essential characteristic	Performance
Characteristic resistance under static and quasi-static loading	See Annex C1 and C2
Characteristic resistance under seismic loading	No performance assessed

3.2 Safety in case of fire (BWR 2)

Essential characteristic	Performance
Reaction to fire	Class A1
Resistance to fire	No performance assessed

4 Assessment and verification of constancy of performance (AVCP) system applied, with reference to its legal base

In accordance with European Assessment Document EAD No. 330087-01-0601, the applicable European legal act is: [96/582/EC].

The system to be applied is: 1

Installation conditions and application examples reinforcing bars, part 1

Figure A1.1:

Overlap joint with existing reinforcement for rebar connections of slabs and beams

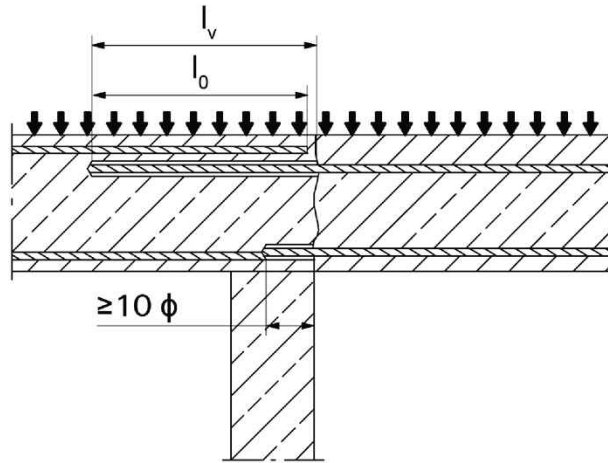

Figure A1.2:

Overlap joint with existing reinforcement at a foundation of a column or wall where the rebar is stressed

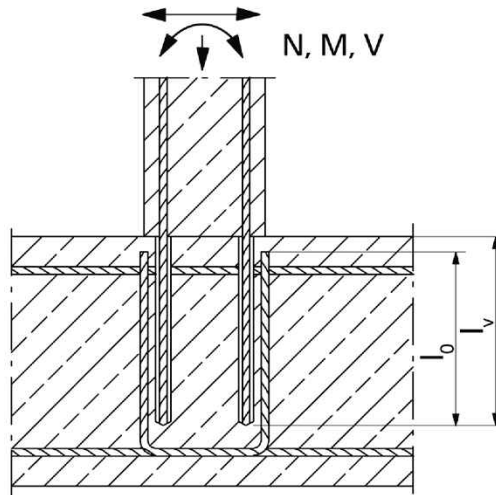
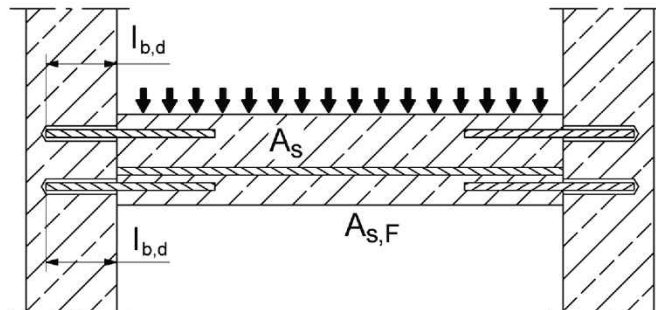

Figure A1.3:

End anchoring of slabs or beams (e.g. designed as simply supported)



Figures not to scale

Rebar connection with fischer injection system FIS SB

Product description

Installation conditions and application examples reinforcing bars, part 1

Annex A1

Appendix 2 / 20

Installation conditions and application examples reinforcing bars, part 2

Figure A2.1:

Rebar connection for stressed primarily in compression

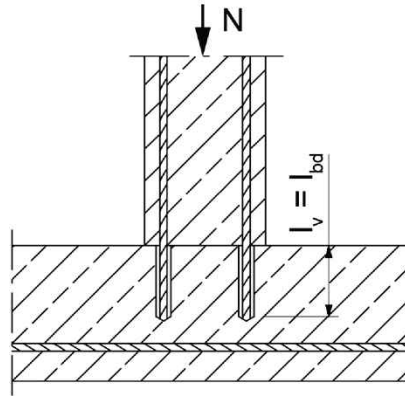
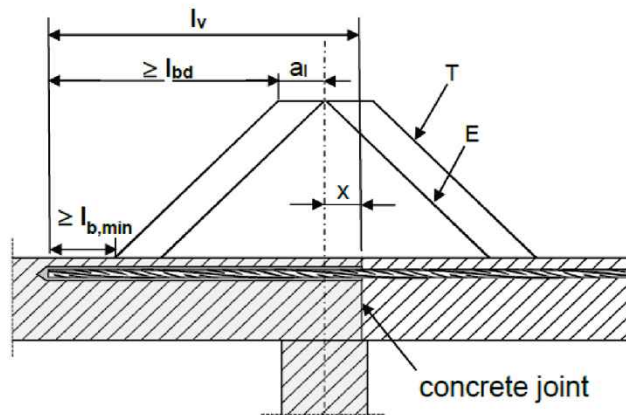

Figure A2.2:

Anchoring of reinforcement to cover the enveloped line of acting tensile force in the bending member



(only post-installed rebar is plotted)

Key to Figure

- T Acting tensile force
- E Envelope of $M_{ed} / z + N_{ed}$ (see EN 1992-1-1:2011)
- x Distance between the theoretical point of support and concrete joint

Note to **figure A1.1 to A1.3** and **figure A2.1 to A2.2**

In the figures no traverse reinforcement is plotted, the transverse reinforcement as required by EN 1992-1-1:2011 shall be present.

The shear transfer between old and new concrete shall be designed according to EN 1992-1-1:2011. Preparation of joints according to **Annex B3** of this document

Figures not to scale

Rebar connection with fischer injection system FIS SB

Product description

Installation conditions and application examples reinforcing bars, part 2

Annex A2

Appendix 3 / 20

Installation conditions and application examples fischer rebar anchor FRA

Figure A3.1:

Lap to a foundation of a column under bending.

1. Shear lug (or fastener loaded in shear)
2. fischer rebar anchor FRA (tension only)
3. Existing stirrup / reinforcement for overlap (lap splice)
4. Slotted hole

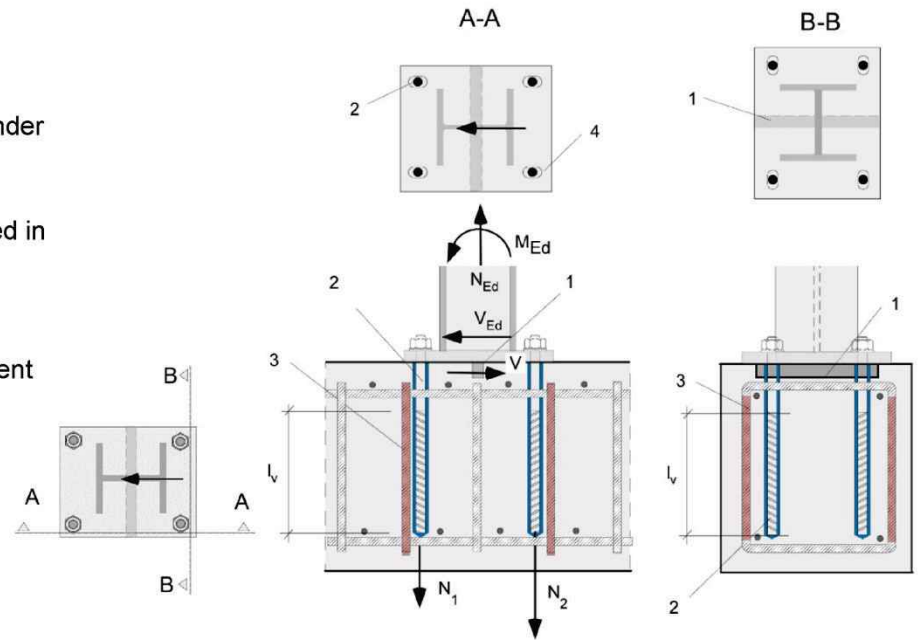
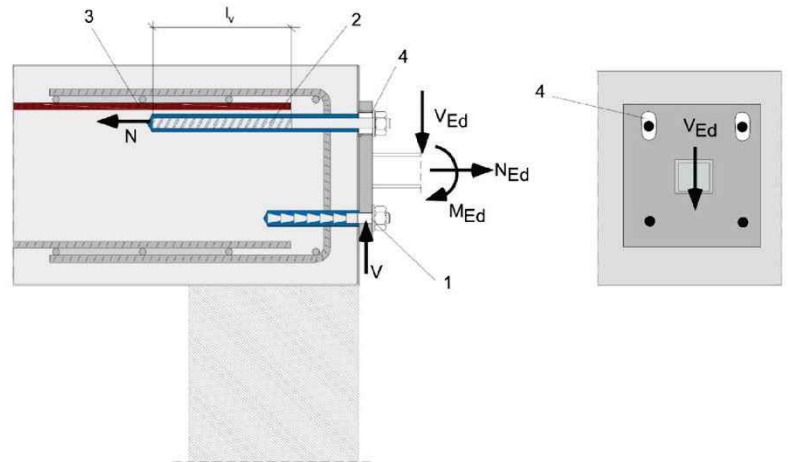

Figure A3.2:

Lap of the anchoring of guardrail posts or anchoring of cantilevered building components.

In the anchor plate, the drill holes for the fischer rebar anchors FRA have to be designed as slotted holes with axial direction to the shear force.

1. Fastener for shear load transfer
2. fischer rebar anchor FRA (tension only)
3. Existing stirrup / reinforcement for overlap (lap splice)
4. Slotted hole



The required transverse reinforcement acc. to EN 1992-1-1:2011 is not shown in the figures. **The fischer rebar anchor FRA may be only used for axial tensile force.** The tensile force must be transferred by lap to the existing reinforcement of the building. The transfer of the shear force has to be ensured by suitable measure, e.g. by means of shear force or anchors with European Technical Assessment (ETA).

Figures not to scale

Rebar connection with fischer injection system FIS SB

Product description

Installation conditions and application examples fischer rebar anchors FRA

Annex A3

Appendix 4 / 20

Overview system components

Injection cartridge (shuttle cartridge) FIS SB with sealing cap; Sizes: 390 ml, 585 ml, 1500 ml

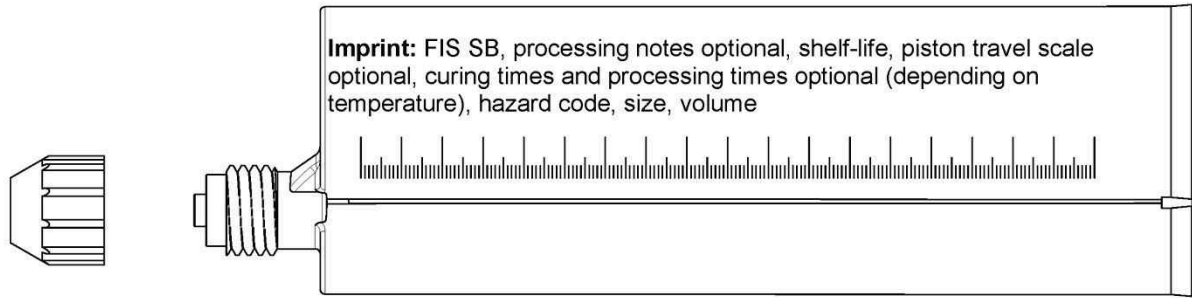

Static mixer FIS MR Plus for injection cartridges ≤ 500 ml

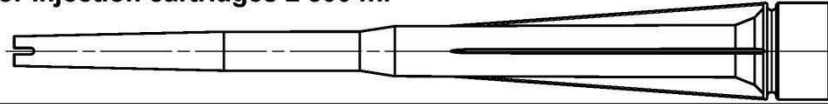

Static mixer FIS UMR for injection cartridges ≥ 500 ml

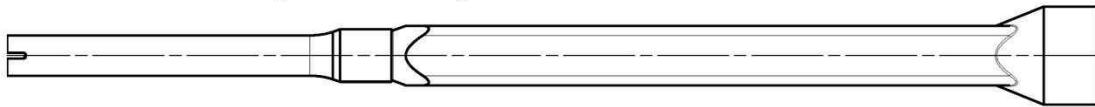

**Injection adapter and extension tube $\varnothing 9$ for static mixer FIS MR Plus;
Injection adapter and extension tube $\varnothing 9$ or $\varnothing 15$ for static mixer FIS UMR**



Reinforcing bar (rebar); Sizes: $\varnothing 8$, $\varnothing 10$, $\varnothing 12$, $\varnothing 14$, $\varnothing 16$, $\varnothing 20$, $\varnothing 25$, $\varnothing 28$, $\varnothing 32$



fischer rebar anchor FRA, FRA HCR; Sizes: M12, M16, M20, M24

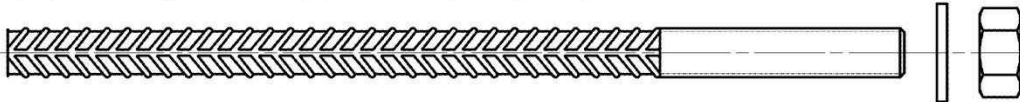

Blow out pump AB G



Compressed-air cleaning tool ABP with compressed-air nozzle

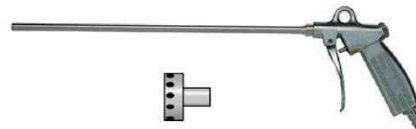

Figures not to scale

Rebar connection with fischer injection system FIS SB

Product description

Overview system components; Injection mortar, static mixer, injection adapter, reinforcing bar, fischer rebar anchor FRA, cleaning tools

Annex A4

Appendix 5 / 20

Properties of reinforcing bars (rebar)

Figure A5.1:



- The minimum value of related rib area $f_{R,min}$ according to EN 1992-1-1:2011
- The maximum outer rebar diameter over the ribs shall be:
 - The nominal diameter of the bar with rib $\phi + 2 \cdot h$ ($h \leq 0,07 \cdot \phi$)
 - (ϕ : Nominal diameter of the bar; h_{rib} = rib height of the bar)

Table A5.1: Installation conditions for rebars

Nominal diameter of the bar		ϕ	8 ¹⁾	10 ¹⁾	12 ¹⁾	14	16	20	25 ¹⁾	28	32				
Nominal drill hole diameter	d_0	[mm]	10	12	12	14	14	16	18	20	25	30	35	35	40
Drill hole depth	h_0		$h_0 = l_v$												
Effective embedment depth	l_v		acc. to static calculation												
Minimum thickness of concrete member	h_{min}		$l_v + 30$ (≥ 100)					$l_v + 2d_0$							

¹⁾ Both drill hole diameters can be used

Table A5.2: Materials of rebars

Designation	Reinforcing bar (rebar)
Reinforcing bar EN 1992-1-1:2011, Annex C	Bars and de-coiled rods class B or C with f_{yk} and k according to NDP or NCI of EN 1992-1-1/NA $f_{uk} = f_{tk} = k \cdot f_{yk}$

Figures not to scale

Rebar connection with fischer injection system FIS SB

Product description
Properties and materials of reinforcing bars (rebar)

Annex A5
Appendix 6 / 20

Properties of fischer rebar anchors FRA

Figure A6.1:

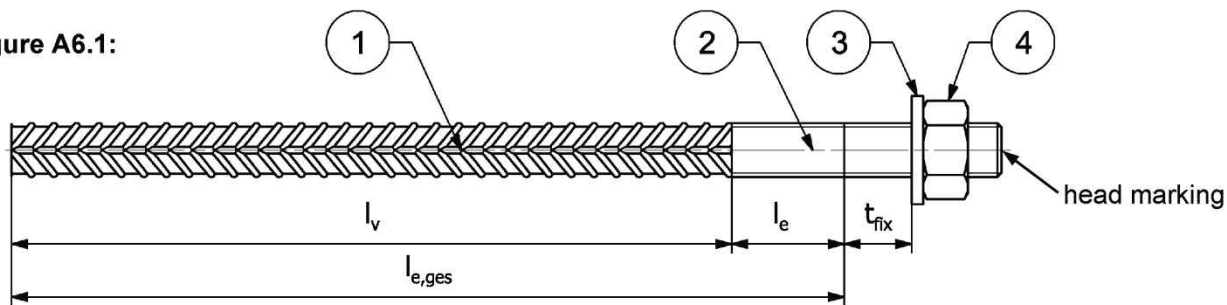



Head marking e.g.:  FRA (for stainless steel)
 FRA HCR (for high corrosion-resistant steel)

Table A6.1: Installation conditions for fischer rebar anchors FRA

Thread diameter		M12 ²⁾		M16	M20	M24 ²⁾	
Nominal diameter	ϕ [mm]	12		16	20	25	
Nominal drill bit diameter	d_0 [mm]	14	16	20	25	30	35
Drill hole depth ($h_0 = l_{e,ges}$)	$l_{e,ges}$ [mm]	$l_v + l_e$					
Effective embedment depth	l_v [mm]	according to static calculation					
Distance concrete surface to welded join	l_e [mm]	100					
Maximum Diameter of clearance hole in the fixture ¹⁾	Pre-positioned d_f [mm]	14		18	22	26	
	Push through d_f [mm]	16	18	22	26	32	40
Minimum thickness of concrete member	h_{min} [mm]	$h_0 + 30$ (≥ 100)		$h_0 + 2d_0$			
Maximum torque moment for attachment of the fixture	$\max T_{inst}$ [Nm]	50		100	150	150	

¹⁾ For bigger clearance holes in the fixture see EN 1992-4:2018

²⁾ Both drill bit diameters can be used

Table A6.2: Materials of fischer rebar anchors FRA

Part	Description	Materials	
		FRA Corrosion resistance class CRC III acc. to EN 1993-1-4:2006+A1:2015	FRA HCR Corrosion resistance class CRC V acc. to EN 1993-1-4: 2006+A1:2015
1	Reinforcing bar	Bars and de-coiled rods class B or C with f_{yk} and k according to NDP or NCI of EN 1992-1-1:NA; $f_{uk} = f_{tk} = k \cdot f_{yk}$; ($f_{yk} = 500 \text{ N/mm}^2$)	
2	Round bar with partial or full thread	Stainless steel, strength class 80, according to EN 10088-1:2023	High corrosion-resistant steel, strength class 80, according to EN 10088-1:2023
3	Washer ISO 7089:2000	Stainless steel, according to EN 10088-1:2023	High corrosion-resistant steel, according to EN 10088-1:2023
4	Hexagon nut	Stainless steel, strength class 80, acc. to EN ISO 3506-2:2020, according to EN 10088-1:2023	High corrosion-resistant steel, strength class 80, acc. to EN ISO 3506-2:2020, according to EN 10088-1:2023

Figures not to scale



Rebar connection with fischer injection system FIS SB

Product description
Properties and materials of fischer rebar anchors FRA

Annex A6
Appendix 7 / 20

Specifications of intended use part 1

Table B1.1: Overview use and performance categories

Anchorages subject to		FIS SB with ...			
		Reinforcing bar 		fischer rebar anchor FRA 	
Hammer drilling or compressed air drilling with standard drill bit 		all sizes			
Use category	I1	dry or wet concrete		all sizes	
Characteristic resistance under static and quasi static loading, in	uncracked concrete	all sizes	Tables: C1.1 C1.2 C1.3	all sizes	Tables: C1.1 C1.2 C1.3 C2.1 C2.2
	cracked concrete				
Characteristic resistance under seismic loading		-1)		-1)	
Installation direction		D3 (downward and horizontal and upwards (e.g. overhead))			
Installation temperature		$T_{i,min} = -15\text{ °C}$ to $T_{i,max} = +40\text{ °C}$			
Service temperature	Temperature range	-40 °C to +80 °C		(max. short term temperature +80 °C; max long term temperature +50 °C)	
Resistance to fire		-1)			

¹⁾ No performance assessed

Rebar connection with fischer injection system FIS SB

Intended use
Specifications part 1

Annex B1
Appendix 8 / 20

Specifications of intended use part 2

Anchorage subject to:

- Static and quasi-static loading: reinforcing bar (rebar) size 8 mm to 32 mm; FRA M12 to M24

Base materials:

- Compacted reinforced or unreinforced normal weight concrete without fibres according to EN 206:2013+A2:2021
- Concrete strength classes C12/15 to C50/60 according to EN 206:2013+A2:2021
- Maximum chloride content of 0,40 % (CL 0.40) related to the cement content according to EN 206:2013+A2:2021
- Non-carbonated concrete

Note: In case of a carbonated surface of the existing concrete structure the carbonated layer shall be removed in the area of the post-installed rebar connection with a diameter of $\phi + 60$ mm prior to the installation of the new rebar. The depth of concrete to be removed shall correspond to at least the minimum concrete cover in accordance with EN 1992-1-1:2011. The foregoing may be neglected if building components are new and not carbonated and if building components are in dry conditions.

Use conditions (Environmental conditions) for fischer rebar anchors FRA

- For all conditions according to EN1993-1-4:2006+A1:2015 corresponding to corrosion resistance classes to **Annex A6 Table A6.2**.

Design:

- The structural design according to EN 1992-1-1:2011 and **Annex B3** and **B4** are conducted under responsibility of a designer experienced in the field of anchorages and concrete works.
- Verifiable calculation notes and drawings are prepared taking account of the forces to be transmitted.
- The actual position of the reinforcement in the existing structure shall be determined on the basis of the construction documentation and taken into account when designing.

Installation:

- The installation of post-installed rebar respectively fischer rebar anchor FRA shall be done only by suitable trained installer and under Supervision on site; the conditions under which an installer may be considered as suitable trained and the conditions for Supervision on site are up to the Member States in which the installation is done.
- Check the position of the existing rebars (if the position of existing rebars is not known, it shall be determined using a rebar detector suitable for this purpose as well as on the basis of the construction documentation and then marked on the building component for the overlap joint).

Rebar connection with fischer injection system FIS SB

Intended use
Specifications part 2

Annex B2
Appendix 9 / 20

General construction rules for post-installed rebars

Figure B3.1:

- Only tension forces in the axis of the rebar may be transmitted.
- The transfer of shear forces between new concrete and existing structure shall be designed additionally according to EN 1992-1-1:2011.
- The joints for concreting must be roughened to at least such an extent that aggregate protrude.

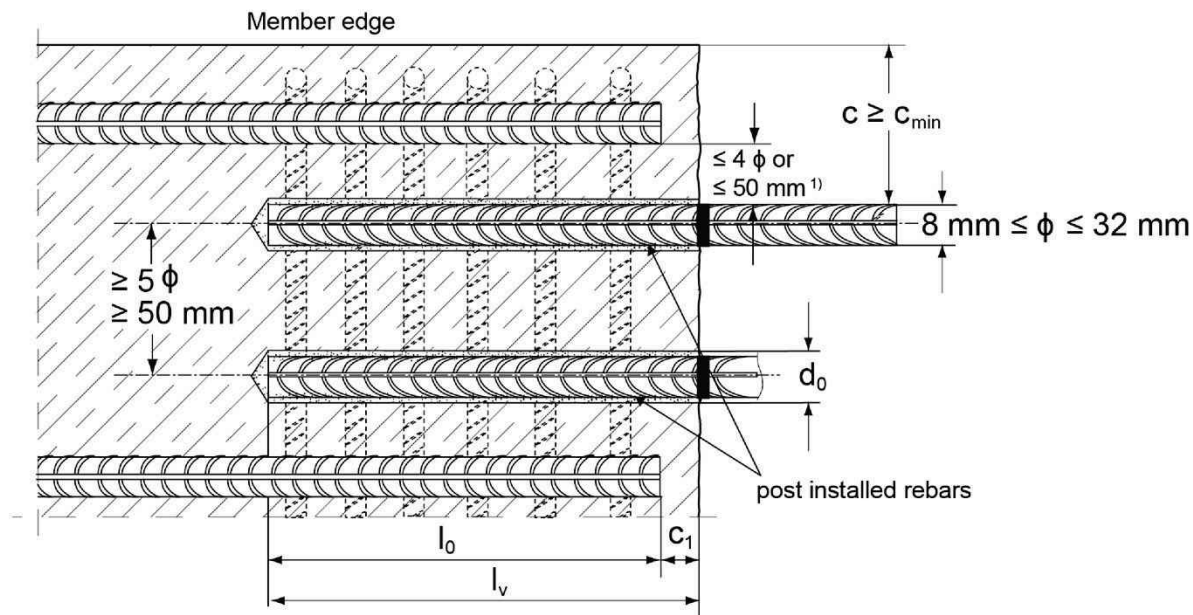

¹⁾ If the clear distance between lapped bars exceeds 4ϕ or 50 mm then the lap length shall be increased by the difference between the clear bar distance and the smaller 4ϕ or 50 mm.

- c concrete cover of post-installed rebar
 c_1 concrete cover at end-face of existing rebar
 c_{min} minimum concrete cover according to **Table B5.1** and to EN 1992-1-1:2011, Section 4.4.1.2
 ϕ nominal diameter of reinforcing bar
 l_0 lap length, according to EN 1992-1-1:2011 for static loading
 l_v effective embedment depth, $\geq l_0 + c_1$
 d_0 nominal drill bit diameter, see **Annex B6**

Figures not to scale

Rebar connection with fischer injection system FIS SB

Intended use
 General construction rules for post-installed rebars

Annex B3
 Appendix 10 / 20

General construction rules for post-installed fischer rebar anchors FRA

Figure B4.1:

- Only tension forces in the axis of the fischer rebar anchor FRA may be transmitted.
- The tension force must be transferred via an overlap joint to the reinforcement in the building part.
- The transmission of the shear load shall be ensured by appropriate additional measures, e.g. by shear lugs or by anchors with a European Technical Assessment (ETA).
- In the anchor plate, the holes for the fischer rebar anchors FRA shall be executed as slotted holes with the axis in the direction of the shear force.
- The length of the bonded-in thread may not be accounted as anchorage.

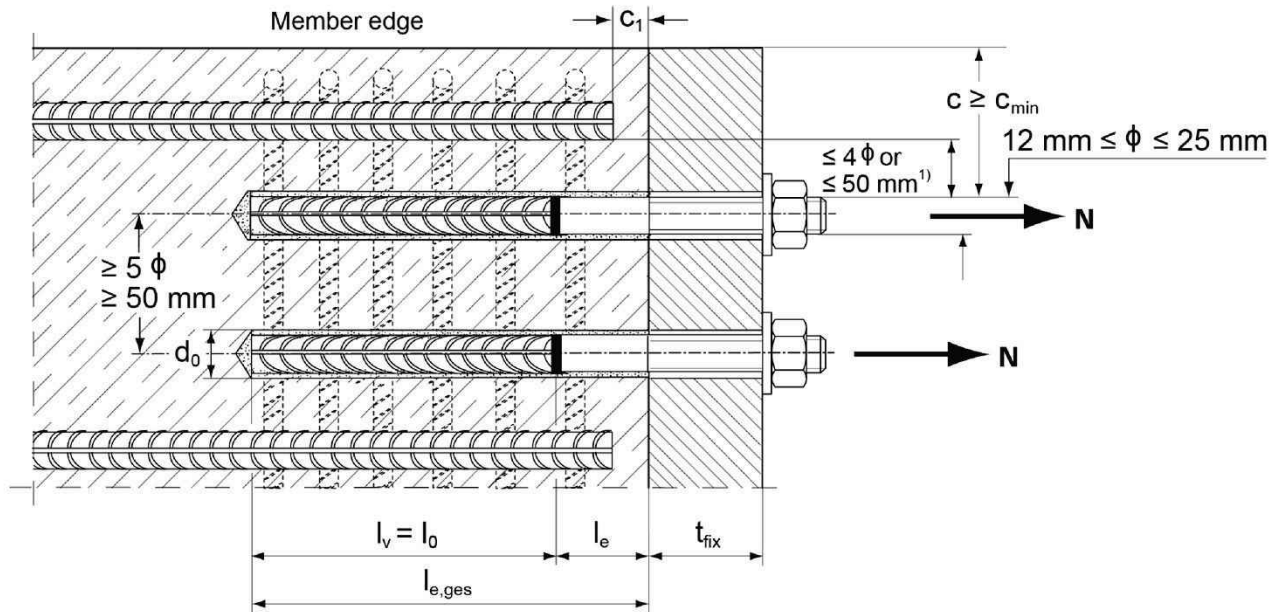

¹⁾ If the clear distance between lapped bars exceeds 4ϕ or 50 mm then the lap length shall be increased by the difference between the clear bar distance and the smaller 4ϕ or 50 mm.

c	concrete cover of post-installed fischer rebar anchor FRA
C_1	concrete cover at end-face of existing rebar
c_{min}	minimum concrete cover according to Table B5.1 and to EN 1992-1-1:2011, Section 4.4.1.2
ϕ	nominal diameter of reinforcing bar
l_0	lap length, according to EN 1992-1-1:2011, Section 8.7.3
$l_{e,ges}$	overall embedment depth, $\geq l_0 + l_e$
d_0	nominal drill bit diameter, see Annex B6
l_e	length of the bonded in threaded part
t_{fix}	thickness of the fixture
l_v	effective embedment depth

Figures not to scale

Rebar connection with fischer injection system FIS SB

Intended use

General construction rules for post-installed fischer rebar anchors FRA

Annex B4

Appendix 11 / 20

Table B5.1: Minimum concrete cover c_{min} ¹⁾ depending of the drilling method and the drilling tolerance

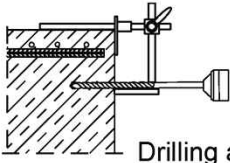
Drilling method	nominal diameter of reinforcing bar ϕ [mm]	Minimum concrete cover c_{min}		
		Without drilling aid [mm]	With drilling aid [mm]	
Hammer drilling with standard drill bit	< 25	30 mm + 0,06 $l_v \geq 2 \phi$	30 mm + 0,02 $l_v \geq 2 \phi$	
	≥ 25	40 mm + 0,06 $l_v \geq 2 \phi$	40 mm + 0,02 $l_v \geq 2 \phi$	
Compressed air drilling	< 25	50 mm + 0,08 l_v	50 mm + 0,02 l_v	
	≥ 25	60 mm + 0,08 $l_v \geq 2 \phi$	60 mm + 0,02 $l_v \geq 2 \phi$	

¹⁾ See Annex B3, figure B3.1 and Annex B4, Figure B4.1

Note: The minimum concrete cover as specified in EN 1992-1-1:2011 must be observed.

Table B5.2: Dispensers and cartridge sizes corresponding to maximum embedment depth $l_{v,max}$

reinforcing bars (rebar)	fischer rebar anchor FRA	Manual or Accu dispenser	Pneumatic dispenser					
		Cartridge size						
ϕ [mm]	thread [-]	390 ml	585 ml	390 ml	585 ml	1500 ml		
		$l_{v,max} / l_{e,ges,max}$ [mm]			$l_{v,max} / l_{e,ges,max}$ [mm]			
8	---	1000		1400	2000	2000	2500	3000
10	---							
12	FRA M12 FRA HCR M12							
14	---							
16	FRA M16 FRA HCR M16	600		1400	2000	2000	2500	3000
20	FRA M20 FRA HCR M20							
25	FRA M24 FRA HCR M24							
28	---							
32	---							
Min. concrete temperature		-15°C					-5°C	
Max. concrete temperature		+40°C					+20°C	

Table B5.3: Conditions for use static mixer without an extension tube

Nominal drill hole diameter d_0	[mm]	10	12	14	16	18	20	25	30	35	40
		Drill hole depth h_0 by FIS MR Plus using		≤ 90	≤ 120	≤ 140	≤ 150	≤ 160	≤ 210		
using FIS UMR		-	-	≤ 90	≤ 160	≤ 180	≤ 190	≤ 220	≤ 250		

Rebar connection with fischer injection system FIS SB

Intended use
Minimum concrete cover;
dispenser and cartridge sizes corresponding to maximum embedment depth

Annex B5
Appendix 12 / 20

Table B6.1: Working times t_{work} and curing times t_{cure}

Temperature in the anchorage base [°C]	Maximum working time t_{work}	Minimum curing time t_{cure}
	FIS SB	FIS SB
-15 to -10	60 min	36 h
>-10 to 5	30 min	24 h
> -5 to 0	20 min	8 h
> 0 to 5	13 min	4 h
> 5 to 10	9 min	120 min
> 10 to 20	5 min	60 min
> 20 to 30	4 min	45 min
> 30 to 40	2 min	30 min

If the temperature in the concrete falls below 0 °C the cartridge must be warmed up to +15 °C.

Table B6.2: Installation tools for drilling and cleaning the bore hole and injection of the mortar

reinforcing bars (rebar) ϕ [mm]	fischer rebar anchor FRA Designation	Drilling and cleaning				Injection	
		Nominal drill bit diameter d_o [mm]	Diameter of cutting edge d_{cut} [mm]	Steel brush diameter d_b [mm]	Diameter of compressed air nozzle [mm]	Diameter of extension tube [mm]	Injection adapter [colour]
8 ¹⁾	---	10	$\leq 10,50$	11,0	---	9	---
		12	$\leq 12,50$	12,5			white
10 ¹⁾	---	12	$\leq 12,50$	12,5	11		blue
		14	$\leq 14,50$	15			red
12 ¹⁾	FRA M12 ¹⁾ FRA HCR M12 ¹⁾	14	$\leq 14,50$	15	15	yellow	
		16	$\leq 16,50$	17		green	
14	---	18	$\leq 18,50$	19	19	black	
16	FRA M16 FRA HCR M16	20	$\leq 20,55$	25		grey	
20	FRA M20 FRA HCR M20	25	$\leq 25,55$	26,5		brown	
25 ¹⁾	FRA M24 ¹⁾ FRA HCR M24 ¹⁾	30	$\leq 30,55$	32	28	brown	
		35	$\leq 35,70$	37		nature	
28	---	35	$\leq 35,70$	37	28	---	
32	---	40	$\leq 40,70$	42		38	---

¹⁾ Both drill bit diameters can be used.

Rebar connection with fischer injection system FIS SB

Intended use
Working times and curing times;
Installation tools for drilling and cleaning the bore hole and injection of the mortar

Annex B6
Appendix 13 / 20

Safety regulations



Review the Safety Data Sheet (SDS) before use for proper and safe handling!
 Wear well-fitting protective goggles and protective gloves when working with mortar FIS SB.
 Important: Observe the instructions for use provided with each cartridge.

Installation instruction part 1; Installation with FIS SB

Hole drilling

Note: Before drilling, remove carbonized concrete; clean contact areas (see **Annex B2**)
 In case of aborted drill holes the drill hole shall be filled with mortar.

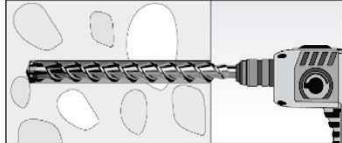
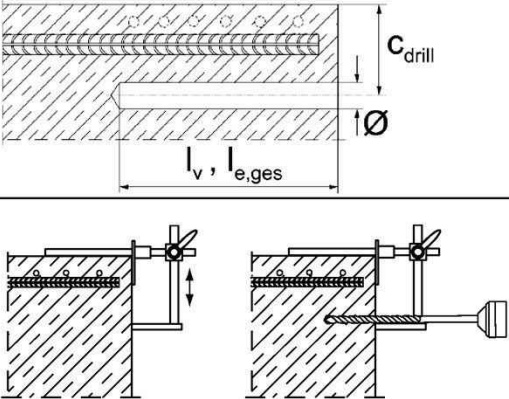
1	Hammer drilling or compressed air drilling 	Drill the hole to the required embedment depth using a hammer drill with carbide drill bit set in rotation hammer mode or a pneumatic drill. Drill bit sizes see Table B6.2 .
2		Measure and control concrete cover c $(c_{drill} = c + \varnothing / 2)$ Drill parallel to surface edge and to existing rebar. Where applicable use drilling aid. For holes $l_v > 20$ cm use drilling aid. Three different options can be considered: A) drilling aid B) Slat or spirit level C) Visual check Minimum concrete cover c_{min} see Table B5.1 .

Rebar connection with fischer injection system FIS SB

Intended use
 Safety regulations; Installation instruction part 1, hole drilling

Installation instruction part 2; Installation with FIS SB

Drill hole cleaning

Hammer or compressed air drilling

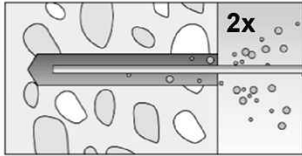

Clean the drill hole:
For $d_0 \leq 18$ mm and
depths l_v resp.
 $l_{e,ges} \leq 160$ mm
blow out the hole two
times by hand.

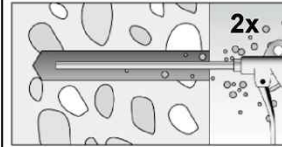

For $d_0 > 18$ mm and
depths l_v resp.
 $l_{e,ges} > 160$ mm blow out
the hole two times with
oil-free compressed air
($p \geq 6$ bar). Use suitable
compressed-air nozzle
(see **Table B6.2**).

3

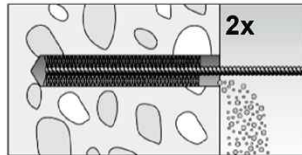

Brush drill hole two times; for drill hole diameters $d_0 \geq 30$ mm attach brush to a power tool and brush hole with a speed of max. 550 revolutions per minute. For deep holes a brush extension is mandatory. Use suitable brushes (see **Table B6.2**).

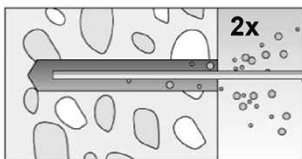

Clean the drill hole:
For $d_0 \leq 18$ mm and
depths l_v resp.
 $l_{e,ges} \leq 160$ mm
blow out the hole two
times by hand.

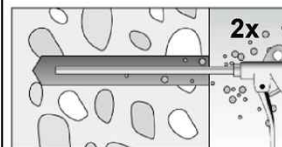

For $d_0 > 18$ mm and
depths l_v resp.
 $l_{e,ges} > 160$ mm blow out
the hole two times with
oil-free compressed air
($p \geq 6$ bar) Use suitable
compressed-air nozzle
(see **Table B6.2**).

Rebar connection with fischer injection system FIS SB

Intended use

Installation instruction part 2, drill hole cleaning

Annex B8

Appendix 15 / 20

Installation instruction part 3; Installation with FIS SB

reinforcing bars (rebar) / fischer rebar anchor FRA and cartridge preparation

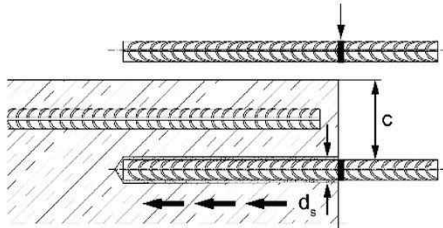
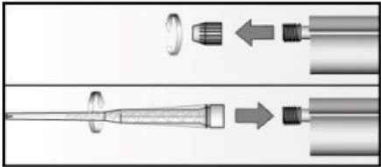
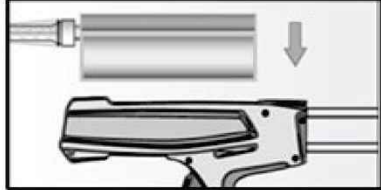
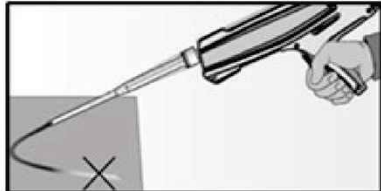
4		<p>Before use, make asure that the rebar or the fischer rebar anchor FRA is dry and free of oil or other residue. Mark the embedment depth l_v (e.g. with tape) Insert rebar in borehole, to verify drill hole depth and setting depth l_v resp. $l_{e,ges}$.</p>
5		<p>Twist off the sealing cap Twist on the static mixer (the spiral in the static mixer must be clearly visible).</p>
6		<p>Place the cartridge into a suitable dispenser.</p>
7		<p>Press out approximately 10 cm of mortar until the resin is permanently grey in colour. Mortar which is not grey in colour will not cure and must be disposed.</p>

Rebar connection with fischer injection system FIS SB

Intended use

Installation instruction part 3,
reinforcing bars (rebar) / fischer rebar anchor FRA and cartridge preparation

Annex B9

Appendix 16 / 20

Installation instruction part 4; Installation with FIS SB

Injection of the mortar without extension tube (see Table 5.3)

8a

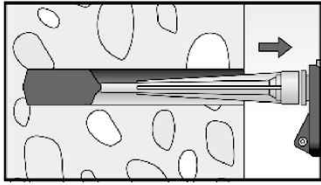

Inject the mortar from the back of the hole towards the front and slowly withdraw the static mixer step by step with each trigger pull. Avoid bubbles. Fill holes approximately 2/3 full, to ensure that the annular gap between the rebar and the concrete will be completely filled with adhesive over the entire embedment length. The conditions for mortar injection without extension tube can be found in **Table B5.3**.

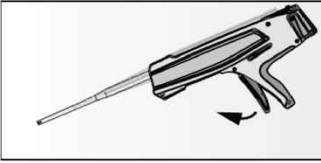

After injecting, release the dispenser. This will prevent further mortar discharge from the static mixer.

Injection of the mortar with extension tube (see Table 5.3)

8b

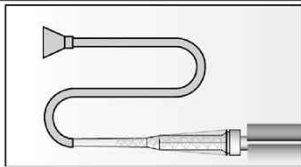

Assemble static mixer, extension tube and appropriate injection adapter (see **Table B6.2**).

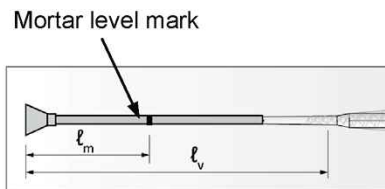

Mark the required mortar level l_m and embedment depth l_v resp. $l_{e,ges}$ with tape or marker on the injection extension tube.

a) Estimation:

$$l_m = \frac{1}{3} \cdot l_v \text{ resp. } l_m = \frac{1}{3} \cdot l_{e,ges} \text{ [mm]}$$

b) Precise equation for optimum mortar volume:

$$l_m = l_v \text{ resp. } l_{e,ges} \left(\left(1,2 \cdot \frac{d_s^2}{d_0^2} - 0,2 \right) \right) \text{ [mm]}$$

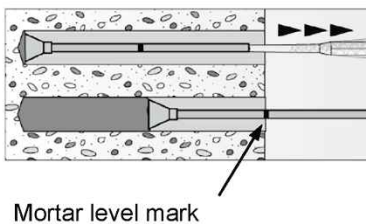

Insert injection adapter to back of the hole. Begin injection allowing the pressure of the injected adhesive mortar to push the injection adapter towards the front of the hole. Do not actively pull out!

Fill holes approximately 2/3 full, to ensure that the annular gap between the rebar and the concrete will be completely filled with adhesive over the embedment length.

When using an injection adapter continue injection until the mortar level mark l_m becomes visible.

Maximum embedment depth see **Table B5.2**.

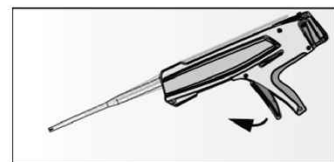

After injecting, release the dispenser. This will prevent further mortar discharge from static mixer.

Rebar connection with fischer injection system FIS SB

Intended use



Installation instruction part 4, mortar injection

Annex B10

Appendix 17 / 20

Installation instruction part 5; Installation with FIS SB

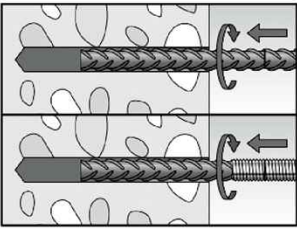
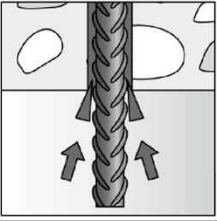
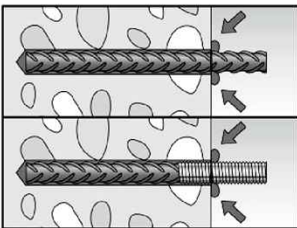
Insert rebar / fischer rebar anchor FRA

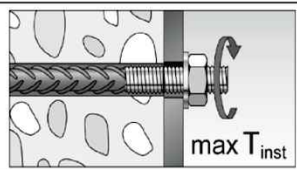
9		<p>Insert the rebar / fischer rebar anchor FRA slowly twisted into the borehole until the embedment mark is reached.</p> <p>Recommendation: Rotation back and forth of the reinforcement bar or the fischer rebar anchor FRA makes pushing easy.</p>
10		<p>For overhead installation, support the rebar / fischer rebar anchor FRA and secure it from falling till mortar started to harden, e.g. using wedges.</p>
11		<p>After installing the rebar or fischer rebar anchor FRA the annular gap must be completely filled with mortar.</p> <p>Proper installation</p> <ul style="list-style-type: none"> • Desired embedment depth is reached l_v, resp. $l_{e,ges}$: embedment mark at concrete surface • Excess mortar flows out of the borehole after the rebar has been fully inserted up to the embedment mark.
12		<p>Observe the working time "t_{work}" (see Table B6.1), which varies according to temperature of base material. Minor adjustments to the rebar / fischer rebar anchor FRA position may be performed during the working time</p> <p>Full load may be applied only after the curing time "t_{cure}" has elapsed (see Table B6.1).</p>
13		<p>Mounting the fixture for fischer rebar anchor FRA, max T_{inst} see Table A6.1.</p>

Rebar connection with fischer injection system FIS SB

Intended use

Installation instruction part 5, insert rebar / fischer rebar anchor FRA

Annex B11

Appendix 18 / 20

Minimum anchorage length and minimum lap length

The minimum anchorage length $l_{b,min}$ and the minimum lap length $l_{o,min}$ according to EN 1992-1-1:2011 shall be multiplied by the relevant amplification factor α_{lb} according to **Table C1.1**.

Table C1.1: Amplification factor α_{lb} related to concrete strength class and drilling method

Hammer drilling, hollow drilling and compressed air drilling									
Rebar / fischer rebar anchor FRA	Amplification factor α_{lb}								
	Concrete strength class								
ϕ [mm]	C12/15	C16/20	C20/25	C25/30	C30/37	C35/45	C40/50	C45/55	C50/60
8 to 32	1,0								

Table C1.2: Bond efficiency factor k_b related to concrete strength class and drilling method

Hammer drilling, hollow drilling and compressed air drilling									
Rebar / fischer rebar anchor FRA	Bond efficiency factor k_b								
	Concrete strength class								
ϕ [mm]	C12/15	C16/20	C20/25	C25/30	C30/37	C35/45	C40/50	C45/55	C50/60
8 to 32	1,0								

Table C1.3: Design values of the bond strength $f_{bd,PIR}$ in N/mm² related to concrete strength class and drilling method for good bond conditions

$$f_{bd,PIR} = k_b \cdot f_{bd}$$

f_{bd} : Design value of the bond strength in N/mm² considering the concrete strength classes and the rebar diameter for good bond condition (for all other bond conditions multiply the values by $\eta_1 = 0,7$) and recommended partial factor $\gamma_c = 1,5$ according to EN 1992-1-1: 2011

k_b : Bond efficiency factor according to **Table C1.2**

Hammer drilling, hollow drilling and compressed air drilling

Rebar / fischer rebar anchor FRA	Bond strength $f_{bd,PIR}$ [N/mm ²]								
	Concrete strength class								
ϕ [mm]	C12/15	C16/20	C20/25	C25/30	C30/37	C35/45	C40/50	C45/55	C50/60
8 to 32	1,6	2,0	2,3	2,7	3,0	3,4	3,7	4,0	4,3

Rebar connection with fischer injection system FIS SB

Performance

Amplification factor α_{lb} , bond efficiency factor k_b , design values of the bond strength $f_{bd,PIR}$

Annex C1

Appendix 19 / 20

Table C2.1: Characteristic tensile yield strength for rebar part of fischer rebar anchors FRA

fischer rebar anchor FRA / FRA HCR			M12	M16	M20	M24
Characteristic tensile yield strength for rebar part						
Rebar diameter	ϕ	[mm]	12	16	20	25
Characteristic tensile yield strength for rebar	f_{yk}	[N/mm ²]	500	500	500	500
Partial factor for rebar part	$\gamma_{Ms,N}^{1)}$	[-]	1,15			

¹⁾ In absence of national regulations

Table C2.2: Characteristic resistance to steel failure under tension loading of fischer rebar anchors FRA

fischer rebar anchor FRA / FRA HCR			M12	M16	M20	M24
Characteristic resistance to steel failure under tension loading						
Characteristic resistance	$N_{Rk,s}$	[kN]	62	111	173	236,5
Partial factor						
Partial factor	$\gamma_{Ms,N}^{1)}$	[-]	1,4			

¹⁾ In absence of national regulations

Rebar connection with fischer injection system FIS SB		Annex C2 Appendix 20 / 20
Performance Characteristic tensile yield strength for rebar part of FRA; Characteristic resistance to steel failure of fischer rebar anchor FRA		