

## PROHLÁŠENÍ O VLASTNOSTECH

### DoP 0395

pro injektážní systém fischer FIS EM Plus (malta pro dodatečné vlepování výztuže)

CS

1. Jedinečný identifikační kód typu výrobku: **DoP 0395**
2. Zamýšlené/zamýšlená použití: **Systém pro dodatečné vlepování výztuže do betonu, Viz. dodatek, obzvláště Přílohy B1-B11.**
3. Výrobce: **fischerwerke GmbH & Co. KG, Otto-Hahn-Straße 15, 79211 Denzlingen, Německo**
4. Zplnomocněný zástupce: **-**
5. Systém/systémy POSV: **1**
6. Evropský dokument pro posuzování: **EAD 330087-01-0601**  
Evropské technické posouzení: **ETA-17/1056; 2026-01-22**  
Subjekt pro technické posuzování: **DIBt- Deutsches Institut für Bautechnik**  
Oznámený subjekt/oznámené subjekty: **2873 TU Darmstadt**
7. Deklarovaná vlastnost/Deklarované vlastnosti:  
**Mechanická odolnost a stabilita (BWR 1)**  
**Charakteristická odolnost při statickém a kvazistatickém zatížení:**  
Pevnost spoje dodatečně vlepované výztuže: Příloha C2  
Redukční faktor: Příloha C1  
Zvětšující faktor pro minimální kotevní délku: Příloha C1  
Charakteristická odolnost proti selhání oceli pro tažené roxorové kotvy: Příloha C1  
  
**Charakteristická odolnost při seismickém zatížení:**  
Pevnost spoje při seismickém zatížení, Faktor účinnosti seismického spoje: Příloha C3  
Minimální krytí betonem při seismickém zatížení: Příloha B5  
  
**Bezpečnost v případě požáru (BWR 2)**  
Odolnost proti ohni: Třídy (A1)  
  
**Požární odolnost:**  
Pevnost spoje při zvýšené teplotě pro dodatečně vlepovanou výztuž hodnocená po dobu 50 let: Příloha C5  
Pevnost spoje při zvýšené teplotě pro dodatečně vlepovanou výztuž hodnocená po dobu 100 let: Příloha C5  
Charakteristická odolnost proti selhání oceli pro tažené roxorové kotvy při vystavení ohni: Příloha C4
8. Příslušná technická dokumentace a/nebo specifická technická dokumentace: **-**

Vlastnosti výše uvedeného výrobku jsou ve shodě se souborem deklarováných vlastností. Toto prohlášení o vlastnostech se v souladu s nařízením (EU) č. 305/2011 vydává na výhradní odpovědnost výrobce uvedeného výše.

Podepsáno za výrobce a jeho jménem:



Alexander Zanocco, Generální ředitel pro prodej a Generální ředitel pro výzkum a vývoj  
Tumlingen, 2026-04-14



Dieter Pfaff, Vedoucí Mezinárodní produkční federace a řízení kvality

Toto PoV bylo připraveno v různých jazykových mutacích. V případě rozporu vždy rozhoduje interpretace verze v anglickém jazyce.

Příloha obsahuje nepovinné a doplňkové informace v anglickém jazyce nad rámec zákonných požadavků.

Translation guidance Essential Characteristics and Performance Parameters for Annexes

**Pokyny pro překlad Základní charakteristiky a výkonnostní parametry příloh**

Mechanical resistance and stability (BWR 1)	
Mechanická odolnost a stabilita (BWR 1)	
Characteristic resistance under static and quasi-static loading: <b>Charakteristická odolnost při statickém a kvazistatickém zatížení:</b>	
1 Bond strength of post-installed rebar: <b>Pevnost spoje dodatečně vlepané výztuže:</b>	$f_{bd,PIR}$ [N/mm <sup>2</sup> ], $f_{bd,PIR,100y}$ [N/mm <sup>2</sup> ]
2 Bond efficiency factor: <b>Redukční faktor:</b>	$k_b$ [-], $k_{b,100y}$ [-]
3 Amplification factor for minimum anchorage length: <b>Zvětšující faktor pro minimální kotevní délku:</b>	$\alpha_{lb}$ [-], $\alpha_{lb,100y}$ [-]
4 Characteristic resistance to steel failure for rebar tension anchors: <b>Charakteristická odolnost proti selhání oceli pro tažené roxorové kotvy:</b>	$N_{Rk,s}$ [kN]
Characteristic resistance under seismic loading: <b>Charakteristická odolnost při seismickém zatížení:</b>	
5 Bond strength under seismic loading, Seismic bond efficiency factor: <b>Pevnost spoje při seismickém zatížení, Faktor účinnosti seismického spoje:</b>	$f_{bd,PIR,seis}$ [N/mm <sup>2</sup> ], $k_{b,seis}$ [-], $f_{bd,PIR,seis,100y}$ [N/mm <sup>2</sup> ], $k_{b,seis,100y}$ [-]
6 Minimum concrete cover under seismic loading: <b>Minimální krytí betonem při seismickém zatížení:</b>	$c_{min,seis}$ [mm]
Safety in case of fire (BWR 2)	
Bezpečnost v případě požáru (BWR 2)	
7 Reaction to fire: <b>Odolnost proti ohni:</b>	Class
Resistance to fire: <b>Požární odolnost:</b>	
8 Bond strength at increased temperature for post-installed rebar assessed for 50 years: <b>Pevnost spoje při zvýšené teplotě pro dodatečně vlepanou výztuž hodnocená po dobu 50 let:</b>	$f_{bd,fi}(\theta)$ [N/mm <sup>2</sup> ], $k_{fi}(\theta)$ [-], $\theta_{max}$ [°C]
9 Bond strength at increased temperature for post-installed rebar assessed for 100 years: <b>Pevnost spoje při zvýšené teplotě pro dodatečně vlepanou výztuž hodnocená po dobu 100 let:</b>	$f_{bd,fi,100y}(\theta)$ [N/mm <sup>2</sup> ], $k_{fi,100y}(\theta)$ [-], $\theta_{max}$ [°C]
10 Characteristic resistance to steel failure for rebar tension anchors under fire exposure: <b>Charakteristická odolnost proti selhání oceli pro tažené roxorové kotvy při vystavení ohni:</b>	$N_{Rk,s,fi}$ [kN]

## Specific Part

### 1 Technical description of the product

The subject of this European Technical Assessment is the post-installed connection, by anchoring or overlap connection joint, of reinforcing bars (rebars) in existing structures made of normal weight concrete, using the "Rebar connection with fischer injection mortar FIS EM Plus" in accordance with the regulations for reinforced concrete construction.

Reinforcing bars with a diameter  $\phi$  from 8 to 40 mm or the fischer rebar anchor FRA of sizes M12 to M24 according to Annex A and the fischer injection mortar FIS EM Plus are used for the post-installed rebar connection. The steel element is placed into a drilled hole filled with injection mortar and is anchored via the bond between embedded reinforcing bar, injection mortar and concrete. The product description is given in Annex A.

### 2 Specification of the intended use in accordance with the applicable European assessment Document

The performances given in Section 3 are only valid if the rebar connection is used in compliance with the specifications and conditions given in Annex B.

The verifications and assessment methods on which this European Technical Assessment is based lead to the assumption of a working life of the rebar connections of at least 50 and/or 100 years. The indications given on the working life cannot be interpreted as a guarantee given by the producer, but are to be regarded only as a means for choosing the right products in relation to the expected economically reasonable working life of the works.

### 3 Performance of the product and references to the methods used for its assessment

#### 3.1 Mechanical resistance and stability (BWR 1)

Essential characteristic	Performance
Characteristic resistance under static and quasi-static loading	See Annex C1 and C2
Characteristic resistance under seismic loading	See Annex B5 and C3

#### 3.2 Safety in case of fire (BWR 2)

Essential characteristic	Performance
Reaction to fire	Class A1
Resistance to fire	See Annex C4 and C5

### 4 Assessment and verification of constancy of performance (AVCP) system applied, with reference to its legal base

In accordance with European Assessment Document EAD No. 330087-01-0601, the applicable European legal act is: [96/582/EC].

The system to be applied is: 1

# Installation conditions and application examples reinforcing bars, part 1

**Figure A1.1:**

Overlap joint with existing reinforcement for rebar connections of slabs and beams

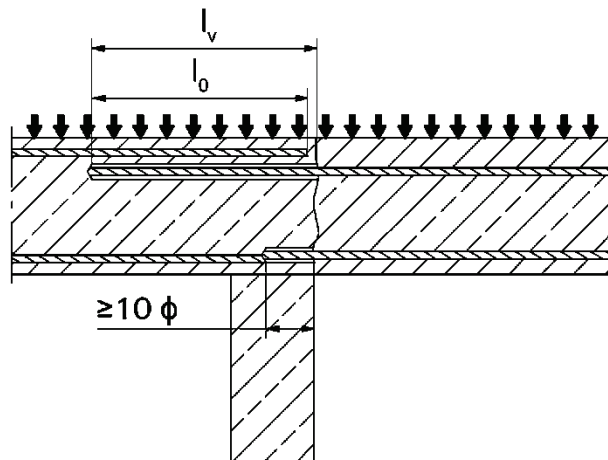

**Figure A1.2:**

Overlap joint with existing reinforcement at a foundation of a column or wall where the rebar is stressed

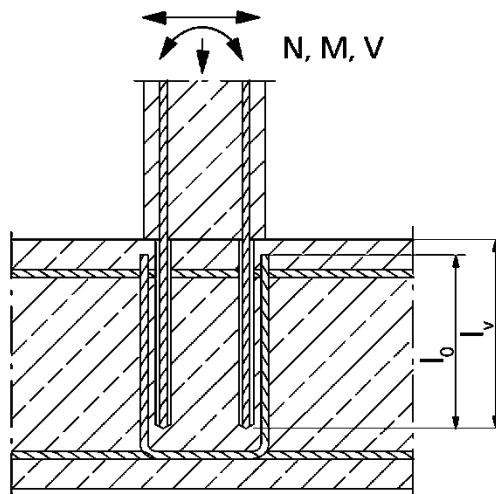

**Figure A1.3:**

End anchoring of slabs or beams (e.g. designed as simply supported)

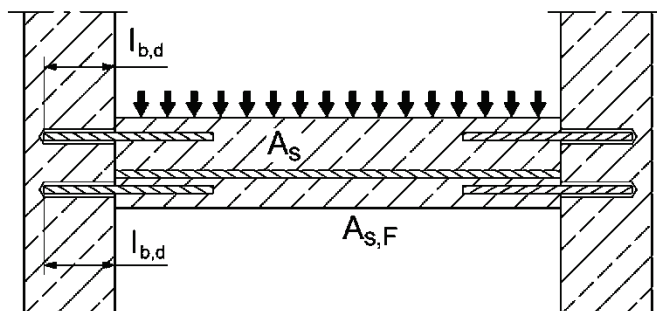

Figures not to scale

Rebar connection with fischer injection mortar FIS EM Plus

**Product description**

Installation conditions and application examples reinforcing bars, part 1

**Annex A1**

Appendix 2 / 24

## Installation conditions and application examples reinforcing bars, part 2

**Figure A2.1:**

Rebar connection for stressed primarily in compression

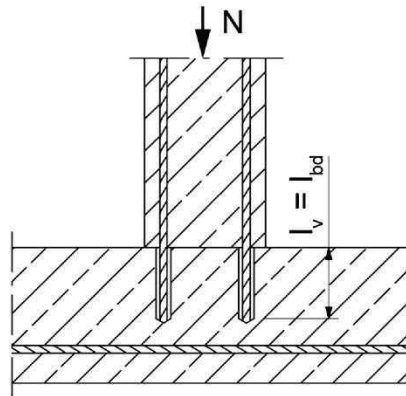

**Figure A2.2:**

Anchoring of reinforcement to cover the enveloped line of acting tensile force in the bending member

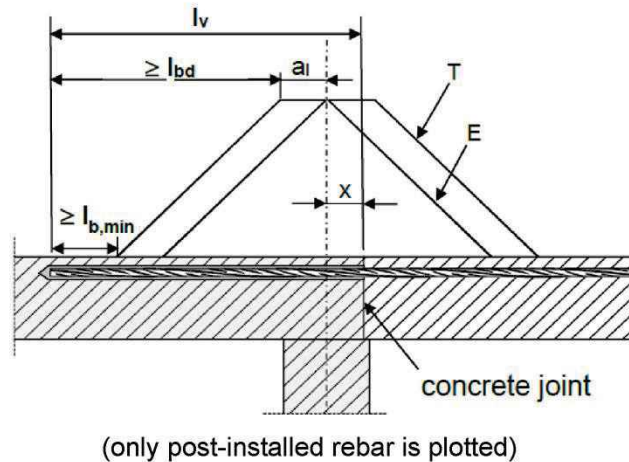

**Key to Figure**

- T Acting tensile force
- E Envelope of  $M_{ed} / z + N_{ed}$  (see EN 1992-1-1:2011)
- x Distance between the theoretical point of support and concrete joint

**Note to figure A1.1 to A1.3 and figure A2.1 to A2.2**

In the figures no traverse reinforcement is plotted, the transverse reinforcement as required by EN 1992-1-1:2011 shall be present.

The shear transfer between old and new concrete shall be designed according to EN 1992-1-1:2011. Preparation of joints according to **Annex B3** of this document.

Figures not to scale

Rebar connection with fischer injection mortar FIS EM Plus

**Product description**

Installation conditions and application examples reinforcing bars, part 2

**Annex A2**

Appendix 3 / 24

# Installation conditions and application examples fischer rebar anchor FRA

**Figure A3.1:**

Lap to a foundation of a column under bending.

1. Shear lug (or fastener loaded in shear)
2. fischer rebar anchor FRA (tension only)
3. Existing stirrup / reinforcement for overlap (lap splice)
4. Slotted hole

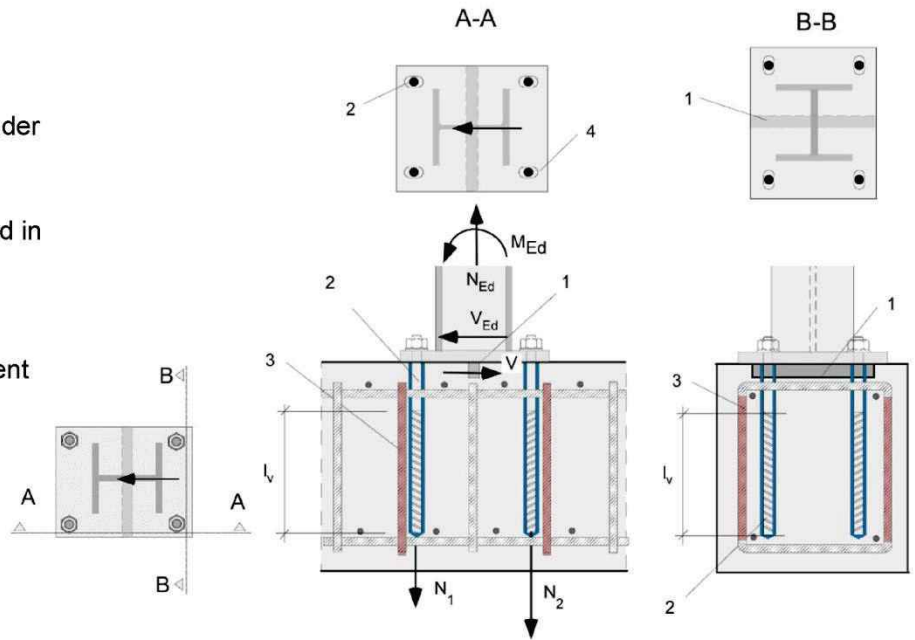
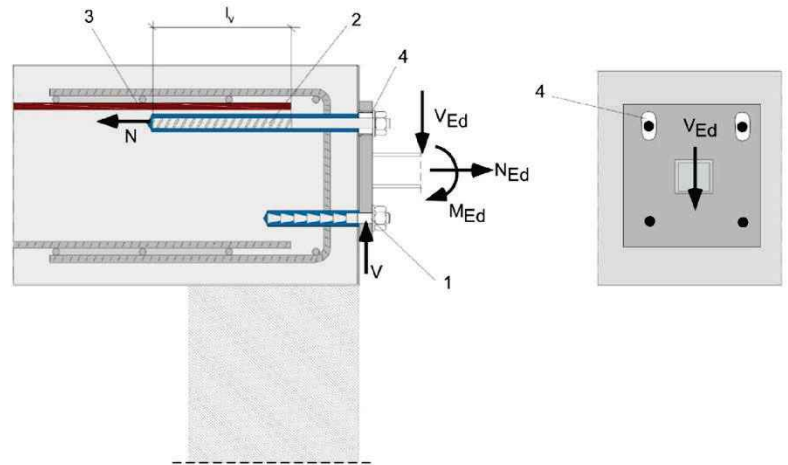

**Figure A3.2:**

Lap of the anchoring of guardrail posts or anchoring of cantilevered building components.

In the anchor plate, the drill holes for the fischer rebar anchors FRA have to be designed as slotted holes with axial direction to the shear force.

1. Fastener for shear load transfer
2. fischer rebar anchor FRA (tension only)
3. Existing stirrup / reinforcement for overlap (lap splice)
4. Slotted hole



The required transverse reinforcement acc. to EN 1992-1-1:2011 is not shown in the figures. **The fischer rebar anchor FRA may be only used for axial tensile force.** The tensile force must transferred by lap to the existing reinforcement of the building. The transfer of the shear force has to be ensured by suitable measure, e.g. by means of shear force or anchors with European Technical Assessment (ETA).

Figures not to scale

Rebar connection with fischer injection mortar FIS EM Plus

**Product description**

Installation conditions and application examples fischer rebar anchors FRA

**Annex A3**

Appendix 4 / 24

## Overview system components Part 1

### Injection cartridge (shuttle cartridge) FIS EM Plus with sealing cap

Sizes: 390 ml, 585 ml, 1500 ml (the 390 ml hard cartridge is shown as an example)

Size foil bag: 500 ml

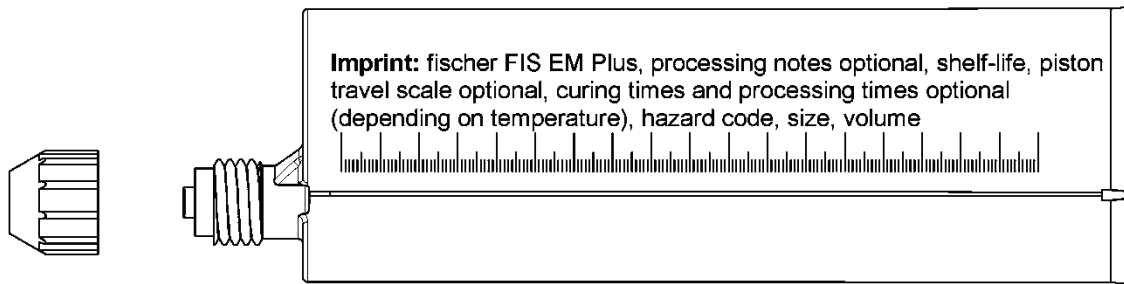

### Injection cartridge (coaxial cartridge) FIS EM Plus with sealing cap

Sizes: 300 ml

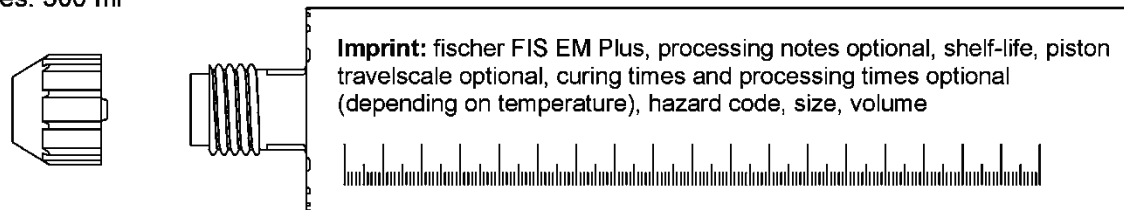

### Static mixer FIS MR Plus for injection cartridges $\leq 500$ ml

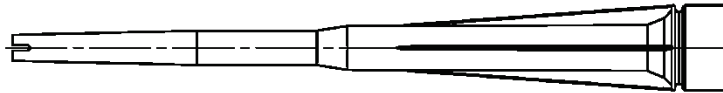

### Static mixer FIS UMR for injection cartridges $\geq 500$ ml

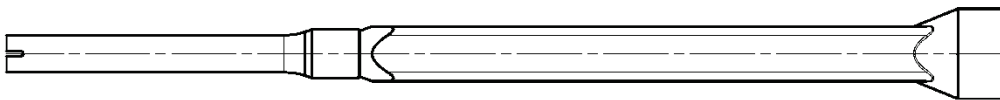

### Injection adapter and extension tube $\varnothing 9$ for static mixer FIS MR Plus; Injection adapter and extension tube $\varnothing 9$ or $\varnothing 15$ for static mixer FIS UMR

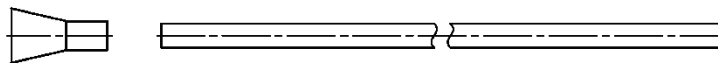

### Compressed-air cleaning tool ABP with fischer compressed-air nozzle

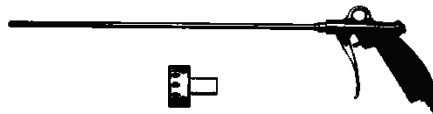

Figures not to scale

Rebar connection with fischer injection mortar FIS EM Plus

#### Product description

Overview system components Part 1;  
Injection mortar, Blow out pump

**Annex A4**

Appendix 5 / 24

## Overview system components Part 2

### Reinforcing bar (rebar)

Sizes:  $\phi 8$ ,  $\phi 10$ ,  $\phi 12$ ,  $\phi 14$ ,  $\phi 16$ ,  $\phi 20$ ,  $\phi 22$ ,  $\phi 24$ ,  $\phi 25$ ,  $\phi 26$ ,  $\phi 28$ ,  $\phi 30$ ,  $\phi 32$ ,  $\phi 34$ ,  $\phi 36$ ,  $\phi 40$



### fischer rebar anchor FRA, FRA HCR

Sizes: M12, M16, M20, M24



Figures not to scale

Rebar connection with fischer injection mortar FIS EM Plus

### Product description

Overview system components Part 2;  
Reinforcing bar, fischer rebar anchor

**Annex A5**  
Appendix 6 / 24

## Properties of reinforcing bars (rebar)

Figure A6.1:



- The minimum value of related rip area  $f_{R,min}$  according to EN 1992-1-1:2011
- The maximum outer rebar diameter over the ribs shall be:
  - The nominal diameter of the rip  $\phi + 2 \cdot h$  ( $h \leq 0,07 \cdot \phi$ )
  - ( $\phi$ : Nominal diameter of the bar;  $h_{rip}$  = rip height of the bar)

**Table A6.1: Installation conditions for rebars**

Nominal diameter of the bar		$\phi$	8 <sup>1)</sup>		10 <sup>1)</sup>		12 <sup>1)</sup>		14	16	20	22	24
Nominal drill hole diameter	$d_0$	[mm]	10	12	12	14	14	16	18	20	25	30	30
Drill hole depth	$h_0$		$h_0 = l_v$										
Effective embedment depth	$l_v$		acc. to static calculation										
Minimum thickness of concrete member	$h_{min}$		$l_v + 30$ ( $\geq 100$ )					$l_v + 2d_0$					

Nominal diameter of the bar		$\phi$	25 <sup>1)</sup>		26	28	30	32	34	36	40	
Nominal drill hole diameter	$d_0$	[mm]	30	35	35	35	40	40	40	45	55	
Drill hole depth	$h_0$		$h_0 = l_v$									
Effective embedment depth	$l_v$		acc. to static calculation									
Minimum thickness of concrete member	$h_{min}$		$l_v + 2d_0$									

<sup>1)</sup> Both drill hole diameters can be used

**Table A6.2: Materials of rebars**

Designation	Reinforcing bar (rebar)
Reinforcing bar EN 1992-1-1:2011, Annex C	Bars and de-coiled rods class B or C with $f_{yk}$ and $k$ according to NDP or NCI of EN 1992-1-1/NA $f_{uk} = f_{tk} = k \cdot f_{yk}$

Figures not to scale

Rebar connection with fischer injection mortar FIS EM Plus

**Product description**  
Properties and materials of reinforcing bars (rebar)

**Annex A6**  
Appendix 7 / 24

## Properties of fischer rebar anchor FRA

Figure A7.1:

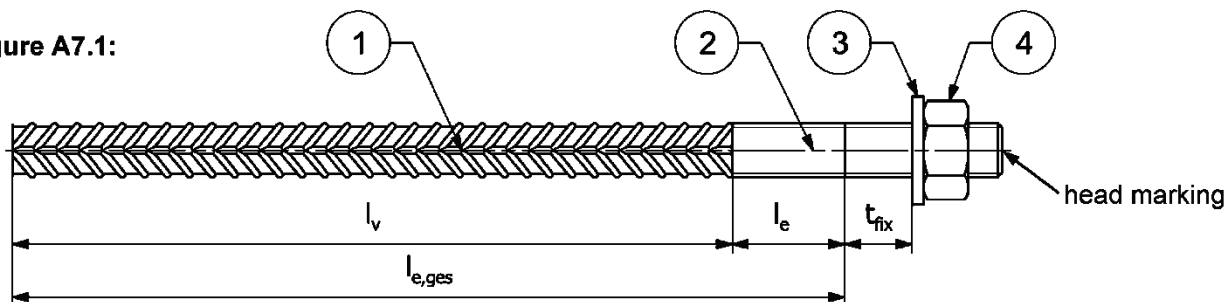

Head marking e.g.:  FRA (for stainless steel)

 FRA HCR (for high corrosion-resistant steel)

Table A7.1: Installation conditions for fischer rebar anchors FRA

Threaded diameter		M12 <sup>2)</sup>	M16	M20	M24 <sup>2)</sup>
Nominal diameter	$\phi$ [mm]	12	16	20	25
Nominal drill bit diameter	$d_0$ [mm]	14   16	20	25	30   35
Drill hole depth ( $h_0 = l_{ges}$ )	$l_{e,ges}$ [mm]	$l_v + l_e$			
Effective embedment depth	$l_v$ [mm]	acc. to static calculation			
Distance concrete surface to welded joint	$l_e$ [mm]	100			
Diameter of clearance hole in the fixture <sup>1)</sup>	Pre-positioned $d_f$ [mm]	14	18	22	26
	Push through $d_f$ [mm]	16   18	22	26	32   40
Minimum thickness of concrete member	$h_{min}$ [mm]	$h_0+30$ ( $\geq 100$ )	$h_0 + 2d_0$		
Maximum torque moment for attachment of the fixture	$\max T_{inst}$ [Nm]	50	100	150	150

<sup>1)</sup> For bigger clearance holes in the fixture see EN 1992-4:2018

<sup>2)</sup> Both drill bit diameters can be used

Table A7.2: Materials of fischer rebar anchors FRA

Part	Description	Materials	
		FRA Corrosion resistance class CRC III acc. to EN 1993-1-4:2006+A1:2015	FRA HCR Corrosion resistance class CRC V acc. to EN 1993-1-4: 2006+A1:2015
1	Reinforcing bar	Bars and de-coiled rods class B or C with $f_{yk}$ and $k$ according to NDP or NCI of EN 1992-1-1:NA; $f_{uk} = f_{tk} = k \cdot f_{yk}$ ( $f_{yk} = 500 \text{ N/mm}^2$ )	
2	Round bar with partial or full thread	Stainless steel, strength class 80, according to EN 10088-1:2023	High corrosion-resistant steel, strength class 80, according to EN 10088-1:2023
3	Washer ISO 7089:2000	Stainless steel, according to EN 10088-1: 2023	High corrosion-resistant steel, according to EN 10088-1: 2023
4	Hexagon nut	Stainless steel, strength class 80, acc. to EN ISO 3506-2:2020, according to EN 10088-1: 2023	High corrosion-resistant steel, strength class 80, acc. to EN ISO 3506-2:2020, according to EN 10088-1: 2023

Figures not to scale





Rebar connection with fischer injection mortar FIS EM Plus

**Product description**  
Properties and materials of fischer rebar anchors

**Annex A7**  
Appendix 8 / 24

# Specifications of intended use part 1

**Table B1.1:** Overview use and performance categories

Anchorages subject to		FIS EM Plus with ...			
		Reinforcing bar 		fischer rebar anchor FRA 	
Hammer drilling or compressed air drilling with standard drill bit 		all sizes			
Hammer drilling with hollow drill bit (fischer "FHD", Heller "Duster Expert"; Bosch „Speed Clean“; Hilti "TE-CD, TE-YD") 		Nominal drill bit diameter ( $d_0$ ) 12 mm to 35 mm			
Diamond drilling 		all sizes			
Use category I1	dry or wet concrete	all sizes			
Static and quasi static load, in	uncracked concrete	all sizes	Tables: C1.1 C1.2 C1.3 C2.1	all sizes	Tables: C1.1 C1.2 C1.3 C1.4 C2.1
	cracked concrete				
Characteristic resistance under seismic loading (only hammer drilling with standard / hollow drill bits)		all sizes	Tables: C3.1 C3.2 C3.3	no performance assessed	
Installation direction	D3 (downward and horizontal and upwards (e.g. overhead))				
Installation temperature	$T_{i,min} = -5\text{ °C}$ to $T_{i,max} = +40\text{ °C}$				
Service temperature	Temperature range	-40 °C to +80 °C		(max. short term temperature +80 °C; max long term temperature +50 °C)	
Resistance to fire		all sizes	Annex C5	all sizes	Annex C4

Rebar connection with fischer injection mortar FIS EM Plus

**Intended use**  
Specifications part 1

**Annex B1**  
Appendix 9 / 24

## Specifications of intended use part 2

### Anchorage subject to:

- Static and quasi-static loading: reinforcing bar (rebar) size 8 mm to 40 mm; FRA M12 to M24
- Characteristic resistance under seismic loading: reinforcing bar (rebar) size 8 mm to 40 mm
- Resistance to fire: reinforcing bar (rebar) size 8 mm to 40 mm; FRA M12 to M24.

### Base materials:

- Compacted reinforced or unreinforced normal weight concrete without fibres according to EN 206:2013+A2:2021
- Strength classes C12/15 to C50/60 according to EN 206:2013+A2:2021
- Maximum chloride content of 0,40 % (CL 0.40) related to the cement content according to EN 206:2013+A2:2021
- Non-carbonated concrete

Note: In case of a carbonated surface of the existing concrete structure the carbonated layer shall be removed in the area of the post-installed rebar connection with a diameter of  $\phi + 60$  mm prior to the installation of the new rebar. The depth of concrete to be removed shall correspond to at least the minimum concrete cover in accordance with EN 1992-1-1:2011. The foregoing may be neglected if building components are new and not carbonated and if building components are in dry conditions

### Use conditions (Environmental conditions) for fischer rebar anchors FRA:

- For all conditions according to EN1993-1-4:2006+A1:2015 corresponding to corrosion resistance classes to **Annex A7 Table A7.2.**

### Design:

- The structural design according to EN 1992-1-1:2011, EN 1992-1-2:2011 and **Annex B3** and **B4** are conducted under responsibility of a designer experienced in the field of anchorages and concrete works.
- Verifiable calculation notes and drawings are prepared taking account of the forces to be transmitted.
- The actual position of the reinforcement in the existing structure shall be determined on the basis of the construction documentation and taken into account when designing.

### Installation:

- The installation of post-installed rebar respectively fischer rebar anchor FRA shall be done only by suitable trained installer and under Supervision on site; the conditions under which an installer may be considered as suitable trained and the conditions for Supervision on site are up to the Member States in which the installation is done.
- Check the position of the existing rebars (if the position of existing rebars is not known, it shall be determined using a rebar detector suitable for this purpose as well as on the basis of the construction documentation and then marked on the building component for the overlap joint).

Rebar connection with fischer injection mortar FIS EM Plus

Intended use  
Specifications part 2

**Annex B2**  
Appendix 10 / 24

## General construction rules for post-installed rebars

**Figure B3.1:**

- Only tension forces in the axis of the rebar may be transmitted
- The transfer of shear forces between new concrete and existing structure shall be designed additionally according to EN 1992-1-1:2011.
- The joints for concreting must be roughened to at least such an extent that aggregate protrude.

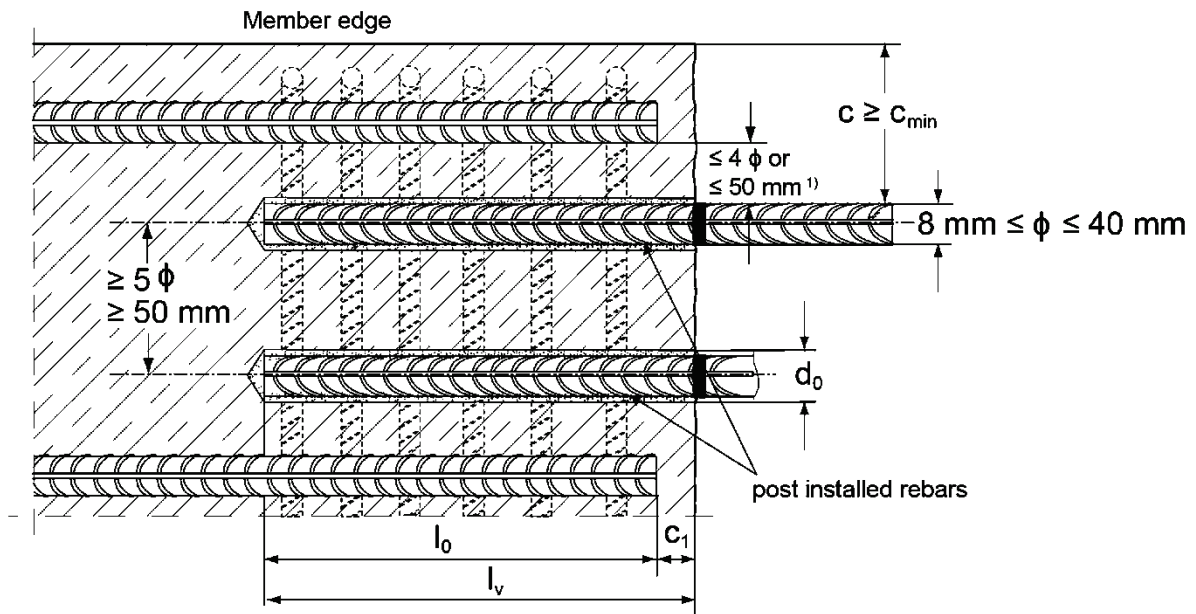

<sup>1)</sup> If the clear distance between lapped bars exceeds  $4 \phi$  or 50 mm then the lap length shall be increased by the difference between the clear bar distance and the smaller  $4 \phi$  or 50 mm.

- $c$  concrete cover of post-installed rebar  
 $c_1$  concrete cover at end-face of existing rebar  
 $c_{min}$  minimum concrete cover according to **Table B5.1** and to EN 1992-1-1:2011, Section 4.4.1.2  
 $\phi$  nominal diameter of reinforcing bar  
 $l_0$  lap length, according to EN 1992-1-1:2011 for static loading and according to EN 1998-1:2004+AC:2009, section 5.6.3 for seismic action.  
 $l_v$  effective embedment depth,  $\geq l_0 + c_1$   
 $d_0$  nominal drill bit diameter, see **Annex B6**

Figures not to scale

Rebar connection with fischer injection mortar FIS EM Plus

**Intended use**  
 General construction rules for for post-installed rebars

**Annex B3**  
 Appendix 11 / 24

## General construction rules for post-installed fischer rebar anchors FRA

**Figure B4.1:**

- Only tension forces in the axis of the fischer rebar anchor FRA may be transmitted.
- The tension force must be transferred via an overlap joint to the reinforcement in the building part.
- The transmission of the shear load shall be ensured by appropriate additional measures, e.g. by shear lugs or by anchors with a European Technical Assessment (ETA).
- In the anchor plate, the holes for the tension anchor shall be executed as slotted holes with the axis in the direction of the shear force.
- The length of the bonded-in thread may not be accounted as anchorage.

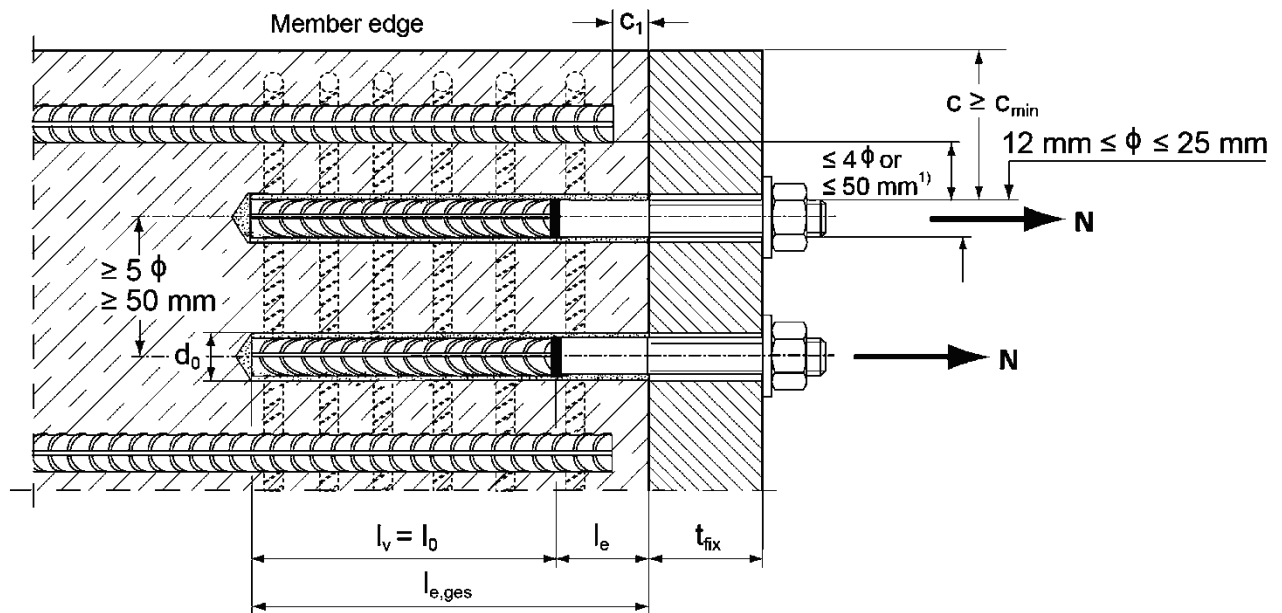

1) If the clear distance between lapped bars exceeds  $4\phi$  or  $50\text{ mm}$  then the lap length shall be increased by the difference between the clear bar distance and the smaller  $4\phi$  or  $50\text{ mm}$ .

$c$	concrete cover of post-installed fischer rebar anchor FRA
$c_1$	concrete cover at end-face of existing rebar
$c_{\min}$	minimum concrete cover according to <b>Table B5.1</b> and to EN 1992-1-1:2011, Section 4.4.1.2
$\phi$	nominal diameter of reinforcing bar
$l_0$	lap length, according to EN 1992-1-1:2011, Section 8.7.3
$l_{e,\text{ges}}$	overall embedment depth, $\geq l_0 + l_e$
$d_0$	nominal drill bit diameter, see <b>Annex B6</b>
$l_e$	length of the bonded in threaded part
$t_{\text{fix}}$	thickness of the fixture
$l_v$	effective embedment depth

Figures not to scale

Rebar connection with fischer injection mortar FIS EM Plus

**Intended use**

General construction rules for post-installed fischer rebar anchors

**Annex B4**

Appendix 12 / 24

**Table B5.1:** Minimum concrete cover  $c_{min} = c_{min,seis}$  <sup>1)</sup> depending of the drilling method and the drilling tolerance

Drilling method	nominal diameter of reinforcing bar $\phi$ [mm]	Minimum concrete cover $c_{min} = c_{min,seis}$	
		Without drilling aid [mm] <sup>2)</sup>	With drilling aid [mm] <sup>2)</sup>
Hammer drilling with standard drill bit	< 25	30 mm + 0,06 $l_v \geq 2 \phi$	30 mm + 0,02 $l_v \geq 2 \phi$
	$\geq 25$	40 mm + 0,06 $l_v \geq 2 \phi$	40 mm + 0,02 $l_v \geq 2 \phi$
Hammer drilling with hollow drill bit	< 25	30 mm + 0,06 $l_v \geq 2 \phi$	30 mm + 0,02 $l_v \geq 2 \phi$
	$\geq 25$	40 mm + 0,06 $l_v \geq 2 \phi$	40 mm + 0,02 $l_v \geq 2 \phi$
Compressed air drilling	< 25	50 mm + 0,08 $l_v$	50 mm + 0,02 $l_v$
	$\geq 25$	60 mm + 0,08 $l_v \geq 2 \phi$	60 mm + 0,02 $l_v \geq 2 \phi$
Diamond drilling	< 25	30 mm + 0,06 $l_v \geq 2 \phi$	30 mm + 0,02 $l_v \geq 2 \phi$
	$\geq 25$	40 mm + 0,06 $l_v \geq 2 \phi$	40 mm + 0,02 $l_v \geq 2 \phi$

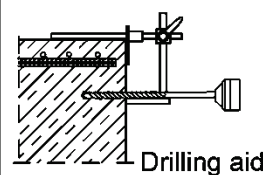

<sup>1)</sup> See Annex B3, figure B3.1 and Annex B4, figure B4.1

Note: The minimum concrete cover as specified in EN 1992-1-1:2011 must be observed. The same minimum concrete covers apply to rebar elements in case of seismic loading.  $c_{min,seis} = 2 \phi$ .

<sup>2)</sup> For FRA (HCR)  $l_{e,ges}$  instead of  $l_v$ .

**Table B5.2:** Dispensers and cartridge sizes corresponding to max. embedment depth  $l_{v,max}$

reinforcing bars (rebar)	fischer rebar anchor	Manual dispenser	Accu and pneumatic dispenser (small)	Pneumatic dispenser (large)
		Cartridge size 300 ml, 390 ml, 500 ml, 585 ml	Cartridge size 300 ml, 390 ml, 500 ml, 585 ml	Cartridge size 1500 ml
$\phi$ [mm]	[-]	$l_{v,max} / l_{e,ges,max}$ [mm]	$l_{v,max} / l_{e,ges,max}$ [mm]	$l_{v,max} / l_{e,ges,max}$ [mm]
8 / 10	---	1000	1000	1800
12	FRA M12 FRA HCR M12		1200	
14	---		1500	
16	FRA M16 FRA HCR M16	1300 <sup>1)</sup>		
20	FRA M20 FRA HCR M20	700	1000 <sup>1)</sup>	2000
22 / 24 / 25	FRA M24 FRA HCR M24		700 <sup>1)</sup>	
26 / 28	---	500	500 <sup>1)</sup>	
30 / 32 / 34 / 36 / 40	---	no performance assessed	500 <sup>1)</sup>	

<sup>1)</sup> Not possible with the 300 ml cartridge

**Table B5.3:** Conditions for use static mixer without an extension tube

Nominal drill hole diameter	$d_0$	[mm]	10	12	14	16	18	20	25	30	35	40	45	55
			Drill hole depth $h_0$ by using	FIS MR Plus	$\leq 90$	$\leq 120$	$\leq 140$	$\leq 150$	$\leq 160$	$\leq 210$				
	FIS UMR	-	-	$\leq 90$	$\leq 160$	$\leq 180$	$\leq 190$	$\leq 220$	$\leq 250$					

Rebar connection with fischer injection mortar FIS EM Plus

**Intended use**  
Minimum concrete cover;  
dispenser and cartridge sizes corresponding to maximum embedment depth

**Annex B5**  
Appendix 13 / 24

**Table B6.1: Working times  $t_{work}$ , initial curing time  $t_{cure,ini}$  and curing times  $t_{cure}$** 

Temperature in the anchorage base [°C]	Maximum working time <sup>1)</sup>	Initial curing time <sup>2)</sup>	Minimum curing time <sup>3)</sup>
	$t_{work}$ FIS EM Plus	$t_{cure,ini}$ FIS EM Plus	$t_{cure}$ FIS EM Plus
-5 to 0	240 min <sup>4)</sup>	62 h	200 h
>0 to 5	150 min <sup>4)</sup>	39 h	90 h
>5 to 10	120 min <sup>4)</sup>	25 h	40 h
>10 to 15	30 min	16 h	18 h
>15 to 20	23 min	11 h	18 h
>20 to 25	14 min	7 h	10 h
>25 to 30	10 min	5 h	10 h
>30 to 35	7 min <sup>5)</sup>	3,5 h	5 h
>35 to 40	5 min <sup>5)</sup>	2,5 h	5 h

- 1) Maximum time from the beginning of the injection to rebar / fischer rebar anchor FRA setting and positioning  
2) After the initial curing time  $t_{cure,ini}$  is reached, the initial bond strength is achieved and allows further processing.  
3) For wet concrete the curing time must be doubled.  
4) If the temperature in the concrete falls below 10°C the cartridge has to be warmed up to +15°C.  
5) If the temperature in the concrete exceeds 30 °C the cartridge has to be cooled down to +15°C up to 20°C.

**Table B6.2: Installation tools for drilling and cleaning the bore hole and injection of the mortar**

reinforcing bars (rebar)	fischer rebar anchor	Drilling and cleaning				Injection	
		Nominal drill bit diameter	Diameter of cutting edge	Steel brush diameter	Diameter of fischer compressed air nozzle	Diameter of extension tube	Injection adapter
$\phi$ [mm]	[-]	$d_0$ [mm]	$d_{cut}$ [mm]	$d_b$ [mm]	[mm]	[mm]	[colour]
8 <sup>1)</sup>	---	10	≤ 10,50	11,0	---	9	---
		12	≤ 12,50	12,5	11		nature
10 <sup>1)</sup>	---	12	≤ 12,50	12,5		15	9
		14	≤ 14,50	15	red		
12 <sup>1)</sup>	FRA M12 <sup>1)</sup>	14	≤ 14,50	15	19	9 or 15	yellow
	FRA HCR M12 <sup>1)</sup>	16	≤ 16,50	17			green
14	---	18	≤ 18,50	19	28	9 or 15	black
16	FRA M16	20	≤ 20,55	21,5			grey
20	FRA M20	25	≤ 25,55	26,5	38	9 or 15	grey
	FRA HCR M20	35	≤ 35,70	37			brown
22 / 24	---	30	≤ 30,55	32	38	9 or 15	brown
25	FRA M24 <sup>1)</sup>	30	≤ 30,55	32			red
	FRA HCR M24 <sup>1)</sup>	35	≤ 35,70	37	38	9 or 15	yellow
26 / 28	---	35	≤ 35,70	37			nature
30 / 32 / 34	---	40	≤ 40,70	42			
36	---	45	≤ 45,70	47			
40	---	55	≤ 55,70	58			

<sup>1)</sup> Both drill bit diameters can be used

Rebar connection with fischer injection mortar FIS EM Plus

**Intended use**

Working times and curing times;  
Installation tools for drilling and cleaning the bore hole and injection of the mortar

**Annex B6**  
Appendix 14 / 24

## Safety regulations



Review the Material Safety Data Sheet (SDS) before use for proper and safe handling!

Wear well-fitting protective goggles and protective gloves when working with mortar FIS EM Plus

Important: Observe the instructions for use provided with each cartridge.

## Installation instruction part 1; Installation with FIS EM Plus

### Hole drilling

Note: Before drilling, remove carbonized concrete; clean contact areas (see **Annex B2**)

In case of aborted drill holes the drill hole shall be filled with mortar.

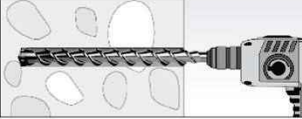
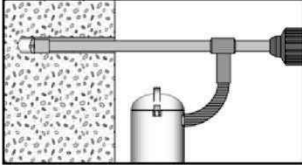
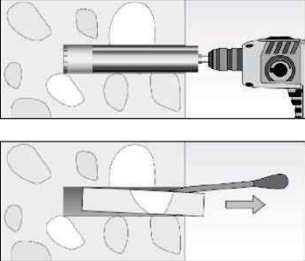
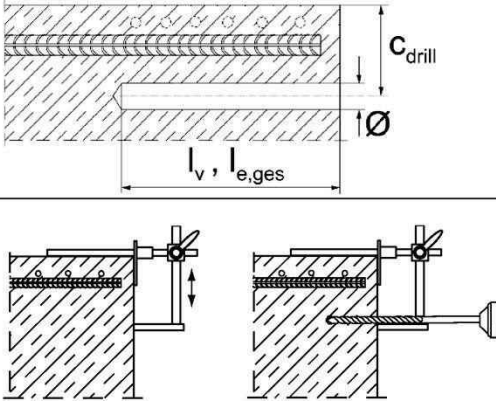
1a	<p><b>Hammer drilling or compressed air drilling</b></p> 	<p>Drill the hole to the required embedment depth using a hammer drill with carbide drill bit set in rotation hammer mode or a pneumatic drill. Drill bit sizes see <b>Table B6.2</b>.</p>
1b	<p><b>Hammer drilling with hollow drill bit</b></p> 	<p>Drill the hole to the required embedment depth using a hammer drill with hollow drill bit in rotation hammer mode. Dust extraction conditions see drill hole cleaning annex B8. Drill bit sizes see <b>Table B6.2</b>.</p>
1c	<p><b>Diamond drilling</b></p> 	<p>Drill the hole to the required embedment depth using a diamond drill in rotation mode. Drill bit sizes see <b>Table B6.2</b>.</p> <p>Break away the drill core and remove it</p>
2		<p>Measure and control concrete cover <math>c</math> (<math>c_{\text{drill}} = c + \varnothing / 2</math>) Drill parallel to surface edge and to existing rebar. Where applicable use Fischer drilling aid.</p> <p>For holes <math>l_v &gt; 20</math> cm use drilling aid. Three different options can be considered: A) Fischer drilling aid B) Slat or spirit level C) Visual check</p> <p>Minimum concrete cover <math>c_{\text{min}}</math> see <b>Table B5.1</b>.</p>

## Rebar connection with Fischer injection mortar FIS EM Plus

### Intended use







Safety regulations; Installation instruction part 1, hole drilling

## Annex B7

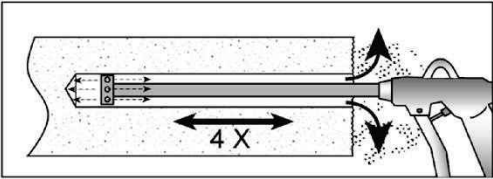
Appendix 15 / 24

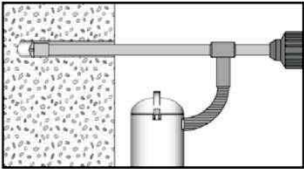
# Installation instruction part 2; Installation with FIS EM Plus

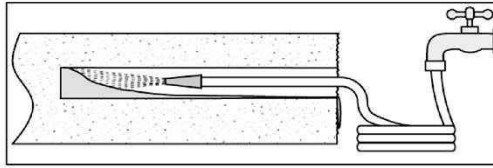
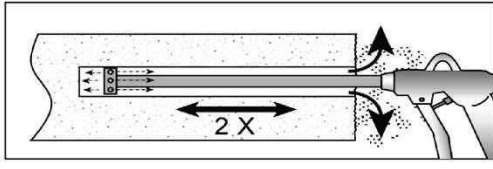
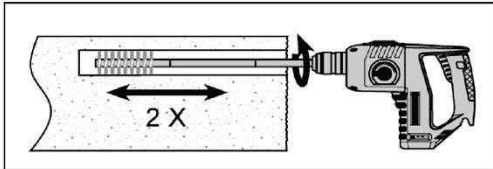
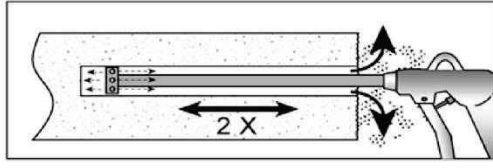
## Drill hole cleaning

<p>3a</p>	<p><b>Hammer or compressed air drilling</b></p> 	 <p>Blowing four times from the back of the hole with the appropriate nozzle (oil-free compressed air <math>\geq 6</math> bar) until return air stream is free of noticeable dust. Personal protective equipment must be used (see regulations <b>Annex B7</b>).</p>
<p>3b</p>	<p><b>Hammer drilling with hollow drill bit</b></p> 	 <p>Use a suitable dust extraction system, e. g. fischer FVC 35 M or a comparable dust extraction system with equivalent performance data. Drill the hole with hollow drill bit. The dust extraction system has to extract the drill dust nonstop during the drilling process and must be adjusted to maximum power. No further drill hole cleaning necessary.</p>
<p>3c</p>	<p><b>Diamond drilling</b></p>    	 <p>Flush the bore hole until the water comes clear.</p> <p>Blowing twice from the back of the hole with the appropriate nozzle (oil-free compressed air <math>\geq 6</math> bar) until return air stream is free of noticeable dust. Personal protective equipment must be used (see regulations <b>Annex B7</b>).</p> <p>Check steel brush with brush control template. Fix an adequate steel brush with an extension into a drilling machine and brush the bore hole twice</p> <p>Blowing twice from the back of the hole with the appropriate nozzle (oil-free compressed air <math>\geq 6</math> bar) until return air stream is free of noticeable dust. Personal protective equipment must be used (see regulations <b>Annex B7</b>).</p>

Rebar connection with fischer injection mortar FIS EM Plus

**Intended use**  
Installation instruction part 2, hole cleaning

**Annex B8**  
Appendix 16 / 24

### Installation instruction part 3; Installation with FIS EM Plus

reinforcing bars (rebar) / fischer rebar anchor FRA and cartridge preparation

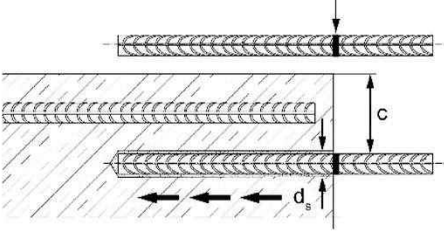
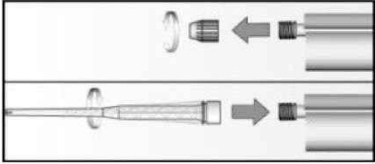
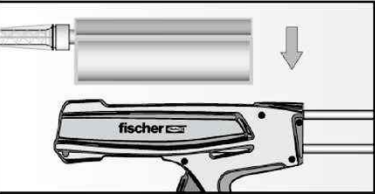
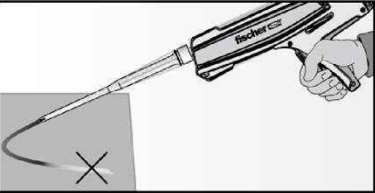
4		<p>Before use, make asure that the rebar or the fischer rebar anchor FRA is dry and free of oil or other residue. Mark the embedment depth <math>l_v</math> on the rebar (e.g. with tape) Insert rebar in borehole, to verify drill hole depth and setting depth <math>l_v</math> resp. <math>l_{e,ges}</math></p>
5		<p>Twist off the sealing cap Twist on the static mixer (the spiral in the static mixer must be clearly visible).</p>
6		<p>Place the cartridge into a suitable dispenser. When using the foilbag, the foil container holder must be used.</p>
7		<p>Press out approximately 10 cm of mortar until the resin is permanently grey in colour. Mortar which is not grey in colour will not cure and must be disposed.</p>

Rebar connection with fischer injection mortar FIS EM Plus

**Intended use**

Installation instruction part 3,  
reinforcing bars (rebar) / fischer rebar anchor and cartridge preparation

**Annex B9**  
Appendix 17 / 24

## Installation instruction part 4; Installation with FIS EM Plus

### Injection of the mortar; borehole depth ≤ 250 mm

8a

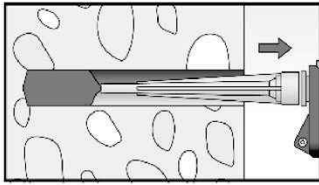

Inject the mortar from the back of the hole towards the front and slowly withdraw the mixing nozzle step by step with each trigger pull. Avoid bubbles.

Fill holes approximately 2/3 full, to ensure that the annular gap between the rebar and the concrete will be completely filled with adhesive over the entire embedment length.

The conditions for mortar injection without extension tube can be found in **Table B5.3**.

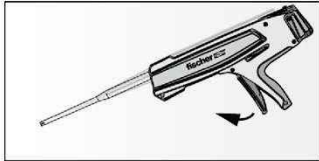

After injecting, release the dispenser. This will prevent further mortar discharge from the mixing nozzle.

### Injection of the mortar; borehole depth > 250 mm

8b

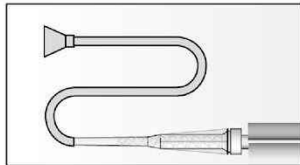

Assemble mixing nozzle FIS MR Plus or FIS UMR, extension tube and appropriate injection adapter (see **Table B 6.2**).

Mortar level mark

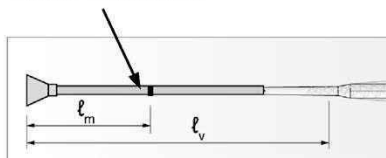

Mark the required mortar level  $l_m$  and embedment depth  $l_v$  resp.  $l_{e,ges}$  with tape or marker on the injection extension tube.

a) Estimation:

$$l_m = \frac{1}{3} * l_v \text{ resp. } l_m = \frac{1}{3} * l_{e,ges} \text{ [mm]}$$

b) Precise equation for optimum mortar volume:

$$l_m = l_v \text{ resp. } l_{e,ges} \left( (1,2 * \frac{d_s^2}{d_0^2} - 0,2) \right) \text{ [mm]}$$

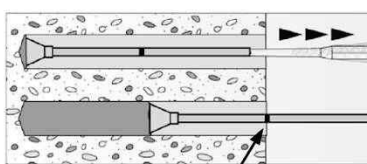

Mortar level mark

Insert injection adapter to back of the hole. Begin injection allowing the pressure of the injected adhesive mortar to push the injection adapter towards the front of the hole. Do not actively pull out!

Fill holes approximately 2/3 full, to ensure that the annular gap between the rebar and the concrete will be completely filled with adhesive over the embedment length.

When using an injection adapter continue injection until the mortar level mark  $l_m$  becomes visible.

Maximum embedment depth see **Table B5.2**.

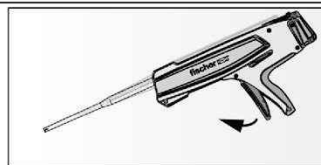

After injecting, release the dispenser. This will prevent further mortar discharge from the mixing nozzle.

Rebar connection with fischer injection mortar FIS EM Plus

**Intended use**

Installation instruction part 4, mortar injection

**Annex B10**

Appendix 18 / 24

## Installation instruction part 5; Installation with FIS EM Plus

### Insert rebar / fischer rebar anchor FRA

9		<p>Insert the rebar / fischer rebar anchor FRA slowly twisted into the borehole until the embedment mark is reached.</p> <p>Recommendation: Rotation back and forth of the reinforcement bar or the fischer rebar anchor FRA makes pushing easy.</p>
10		<p>For overhead installation, support the rebar / fischer rebar anchor FRA and secure it from falling till mortar started to harden, e.g. using wedges.</p>
11		<p>After installing the rebar or fischer rebar anchor FRA the annular gap must be completely filled with mortar.</p> <p>Proper installation</p> <ul style="list-style-type: none"> <li>• Desired embedment depth is reached <math>l_v</math>: embedment mark at concrete surface.</li> <li>• Excess mortar flows out of the borehole after the rebar has been fully inserted up to the embedment mark.</li> </ul>
12		<p>Observe the working time "<math>t_{work}</math>" (see <b>Table B6.1</b>), which varies according to temperature of base material. Minor adjustments to the rebar / fischer rebar anchor position may be performed during the working time</p> <p>After the initial curing time <math>t_{cure,ini}</math> (see <b>Table B6.1</b>) is reached, the initial bond strength is achieved and allows further processing.</p> <p>Full load may be applied only after the curing time "<math>t_{cure}</math>" has elapsed (see <b>Table B 6.1</b>)</p>
13		<p>Mounting the fixture for fischer rebar anchor FRA, max <math>T_{inst}</math> see <b>Table A7.1</b>.</p>

Rebar connection with fischer injection mortar FIS EM Plus

#### Intended use

Installation instruction part 5, insert rebar / fischer rebar anchor

**Annex B11**

Appendix 19 / 24

### Minimum anchorage length and minimum lap length

The minimum anchorage length  $l_{b,min}$  and the minimum lap length  $l_{0,min}$  according to EN 1992-1-1:2011 shall be multiply by the relevant amplification factor  $\alpha_{lb} = \alpha_{lb,100y}$  according to **Table C1.1**.

**Table C1.1:** Amplification factor  $\alpha_{lb} = \alpha_{lb,100y}$  related to concrete strength class and drilling method with a service life of 50 or 100 years

Hammer drilling, hollow drilling and compressed air drilling									
Rebar / fischer rebar anchor FRA $\phi$ [mm]	Amplification factor $\alpha_{lb} = \alpha_{lb,100y}$								
	Concrete strength class								
	C12/15	C16/20	C20/25	C25/30	C30/37	C35/45	C40/50	C45/55	C50/60
8 to 25	1,0								
26 to 40	1,0								

Diamond drilling									
Rebar / fischer rebar anchor FRA $\phi$ [mm]	Amplification factor $\alpha_{lb} = \alpha_{lb,100y}$								
	Concrete strength class								
	C12/15	C16/20	C20/25	C25/30	C30/37	C35/45	C40/50	C45/55	C50/60
8 to 12		1,0		1,04	1,08	1,13	1,17	1,21	1,25
14 to 25		1,0		1,04	1,08	1,13	1,17	1,21	1,25
26 to 40		1,0		1,08	1,17	1,25	1,33	1,42	1,50

**Table C1.2:** Bond efficiency factor  $k_b = k_{b,100y}$  for hammer drilling, hollow drilling and compressed air drilling with a service life of 50 or 100 years

Hammer drilling, hollow drilling and compressed air drilling									
Rebar / fischer rebar anchor FRA $\phi$ [mm]	Bond efficiency factor $k_b = k_{b,100y}$								
	Concrete strength class								
	C12/15	C16/20	C20/25	C25/30	C30/37	C35/45	C40/50	C45/55	C50/60
8 to 25	1,0								0,98
26 to 40	1,0								0,98

**Table C1.3:** Bond efficiency factor  $k_b = k_{b,100y}$  for diamond drilling with a service life of 50 or 100 years

Diamond drilling									
Rebar / fischer rebar anchor FRA $\phi$ [mm]	Bond efficiency factor $k_b = k_{b,100y}$								
	Concrete strength class								
	C12/15	C16/20	C20/25	C25/30	C30/37	C35/45	C40/50	C45/55	C50/60
8 to 12	1,0								0,95
14 to 25	1,0								0,95
26 to 40			1,0			0,96	0,87	0,81	0,76

**Table C1.4:** Characteristic resistance to steel failure under tension loading of fischer rebar anchors FRA

fischer rebar anchor FRA / FRA HCR	M12	M16	M20	M24
<b>Characteristic resistance to steel failure under tension loading</b>				
Characteristic resistance $N_{Rk,s}$ [kN]	62,0	111,0	173,0	236,5
<b>Partial factor</b>				
Partial factor $\gamma_{Ms,N}^{1)}$ [-]	1,4			

<sup>1)</sup> In absence of national regulations

Rebar connection with fischer injection mortar FIS EM Plus

#### Performance

Amplification factor  $\alpha_{lb} = \alpha_{lb,100y}$  bond efficiency factor  $k_b = k_{b,100y}$

**Table C2.1:** Design values of the bond strength  $f_{bd,PIR} = f_{bd,PIR,100y}$  in N/mm<sup>2</sup> related to concrete strength class and drilling method for good bond conditions; service life 50 or 100 years

$$f_{bd,PIR} = k_b \cdot f_{bd}$$

$$f_{bd,PIR,100y} = k_{b,100y} \cdot f_{bd}$$

$f_{bd}$ : Design value of the bond strength in N/mm<sup>2</sup> considering the concrete strength classes and the rebar diameter for good bond condition (for all other bond conditions multiply the values by  $\eta_1 = 0,7$ ) and recommended partial factor  $\gamma_c = 1,5$  according to EN 1992-1-1:2011

$k_b$  Bond efficiency factor according to table C1.2 and C1.3

$k_{b,100y}$  Bond efficiency factor according to table C1.2 and C1.3

**Hammer drilling, hollow drilling and compressed air drilling**

Rebar / fischer rebar anchor FRA	bond strength $f_{bd,PIR} = f_{bd,PIR,100y}$ [N/mm <sup>2</sup> ]								
	Concrete strength class								
	C12/15	C16/20	C20/25	C25/30	C30/37	C35/45	C40/50	C45/55	C50/60
$\phi$ [mm]									
8-32	1,6	2,0	2,3	2,7	3,0	3,4	3,7	4,0	4,2
34	1,6	2,0	2,3	2,6	2,9	3,3	3,6	3,9	4,1
36	1,5	1,9	2,2	2,6	2,9	3,3	3,6	3,8	4,0
40	1,5	1,8	2,1	2,5	2,8	3,1	3,4	3,7	3,9

**Diamond drilling**

Rebar / fischer rebar anchor FRA	bond strength $f_{bd,PIR} = f_{bd,PIR,100y}$ [N/mm <sup>2</sup> ]								
	Concrete strength class								
	C12/15	C16/20	C20/25	C25/30	C30/37	C35/45	C40/50	C45/55	C50/60
$\phi$ [mm]									
8-12						3,4	3,7	4,0	4,1
14-25	1,6	2,0	2,3	2,7	3,0	3,4	3,7	4,0	4,1
26-32						3,2	3,2	3,2	3,2
34	1,6	2,0	2,3	2,6	2,9	3,1	3,1	3,1	3,1
36	1,5	1,9	2,2	2,6	2,9	3,1	3,1	3,1	3,1
40	1,5	1,8	2,1	2,5	2,8	2,9	2,9	2,9	2,9

Rebar connection with fischer injection mortar FIS EM Plus

**Performance**

Design values of the bond strength  $f_{bd,PIR} = f_{bd,PIR,100y}$

**Annex C2**

Appendix 21 / 24

## Minimum anchorage length and minimum lap length under seismic conditions

The minimum anchorage length  $l_{b,min}$  and the minimum lap length  $l_{0,min}$  according to EN 1992-1-1:2011 shall be multiply by the relevant amplification factor  $\alpha_{lb,seis}$  according to **Table C3.1**.

**Table C3.1:** Amplification factor  $\alpha_{lb,seis} = \alpha_{lb,seis,100y}$  related to concrete strength class and drilling method

### Hammer drilling, hollow drilling and compressed air drilling

Rebar $\phi$ [mm]	Amplification factor $\alpha_{lb,seis} = \alpha_{lb,seis,100y}$							
	Concrete strength class							
	C16/20	C20/25	C25/30	C30/37	C35/45	C40/50	C45/55	C50/60
8 to 25	1,0							
26 to 40	1,0							

**Table C3.2:** Bond efficiency factor  $k_{b,seis} = k_{b,seis,100y}$  for hammer drilling, hollow drilling and compressed air drilling with a service life of 50 or 100 years

### Hammer drilling, hollow drilling and compressed air drilling

Rebar $\phi$ [mm]	Bond efficiency factor $k_{b,seis} = k_{b,seis,100y}$							
	Concrete strength class							
	C16/20	C20/25	C25/30	C30/37	C35/45	C40/50	C45/55	C50/60
8 to 25	1,00							0,98
26 to 40	1,00							0,98

**Table C3.3:** Design values of the bond strength  $f_{bd,PIR,seis} = f_{bd,PIR,seis,100y}$  in N/mm<sup>2</sup> for hammer drilling, hollow drilling and compressed air drilling **under seismic action** and for good bond conditions with a service life of 50 or 100 years

$$f_{bd,PIR,seis} = k_{b,seis} \cdot f_{bd}$$

$$f_{bd,PIR,seis,100y} = k_{b,seis,100y} \cdot f_{bd}$$

### Hammer drilling, hollow drilling and compressed air drilling

Rebar $\phi$ [mm]	bond strength $f_{bd,PIR,seis} = f_{bd,PIR,seis,100y}$ [N/mm <sup>2</sup> ]							
	Concrete strength class							
	C16/20	C20/25	C25/30	C30/37	C35/45	C40/50	C45/55	C50/60
8-32	2,0	2,3	2,7	3,0	3,4	3,7	4,0	4,2
34	1,6	2,0	2,3	2,6	2,9	3,3	3,6	3,9
36	1,5	1,9	2,2	2,6	2,9	3,3	3,6	3,8
40	1,5	1,8	2,1	2,5	2,8	3,1	3,4	3,7

Rebar connection with fischer injection mortar FIS EM Plus

#### Performance

Amplification factor  $\alpha_{lb,seis} = \alpha_{lb,seis,100y}$ , bond efficiency factor  $k_{b,seis} = k_{b,seis,100y}$ , Design values of the bond strength  $f_{bd,PIR,seis} = f_{bd,PIR,seis,100y}$

#### Annex C3

Appendix 22 / 24

**Table C4.1: Essential characteristics to steel failure for fischer rebar anchors FRA under fire exposure**

according to EN 1992-4:2018; for concrete strength classes C12/C15 to C50/60

fischer rebar anchor FRA / FRA HCR				M12	M16	M20	M24
Characteristic resistance to steel failure	R30	N <sub>Rk,s,fi</sub>	[kN]	2,5	4,7	7,3	10,5
	R60			2,1	3,9	6,1	8,8
	R90			1,6	3,1	4,9	7,1
	R120			1,3	2,5	3,9	5,6

Rebar connection with fischer injection mortar FIS EM Plus

**Performance**

Characteristic resistance to steel failure N<sub>Rk,s,fi</sub> under fire exposure for fischer rebar anchor

**Annex C4**

Appendix 23 / 24

## Bond strength $f_{bk,fi} = f_{bk,fi,100y}$ at increased temperature for concrete strength classes C12/15 to C50/60 (all drilling methods)

The bond strength  $f_{bk,fi} = f_{bk,fi,100y}$  at increased temperature has to be calculated by the following equation:

$$f_{bk,fi} = f_{bk,fi,100y} = k_{fi}(\theta) \cdot f_{bd,PIR} \cdot \frac{\gamma_c}{\gamma_{M,fi}}$$

If:  $\theta > 46 \text{ }^\circ\text{C}$        $k_{fi}(\theta) = \frac{862,3 \cdot \theta^{-1,166}}{f_{bd,PIR} \cdot 4,3} \leq 1,0$

If:  $\theta > \theta_{max} (284 \text{ }^\circ\text{C})$        $k_{fi}(\theta) = 0$

$f_{bk,fi}$ =	=	Bond strength at increased temperature in N/mm <sup>2</sup> for service life 50 years
$f_{bk,fi,100y}$	=	Bond strength at increased temperature in N/mm <sup>2</sup> for service life 100 years
$\theta$	=	Temperature in °C in the mortar layer
$k_{fi}(\theta)$	=	Reduction factor at increased temperature
= $k_{fi,100y}(\theta)$		
$f_{bd,PIR}$ =	=	Design value of the bond strength in N/mm <sup>2</sup> in cold condition according to table C2.1 considering the concrete classes, the rebar diameter, the drilling method and the bond conditions according to EN 1992-1-1:2011
$\gamma_c$	=	1,5 recommended partial factor according to EN 1992-1-1:2011
$\gamma_{M,fi}$	=	1,0 recommended partial factor according to EN 1992-1-2:2011

For evidence at increased temperature the anchorage length shall be calculated according to EN 1992-1-1:2011 Equation 8.3 using the temperature-dependent ultimate bond strength  $f_{bk,fi}$ .

**Figure C5.1:** Example graph of reduction factor  $k_{fi}(\theta)$  for concrete class C20/25 for good bond conditions

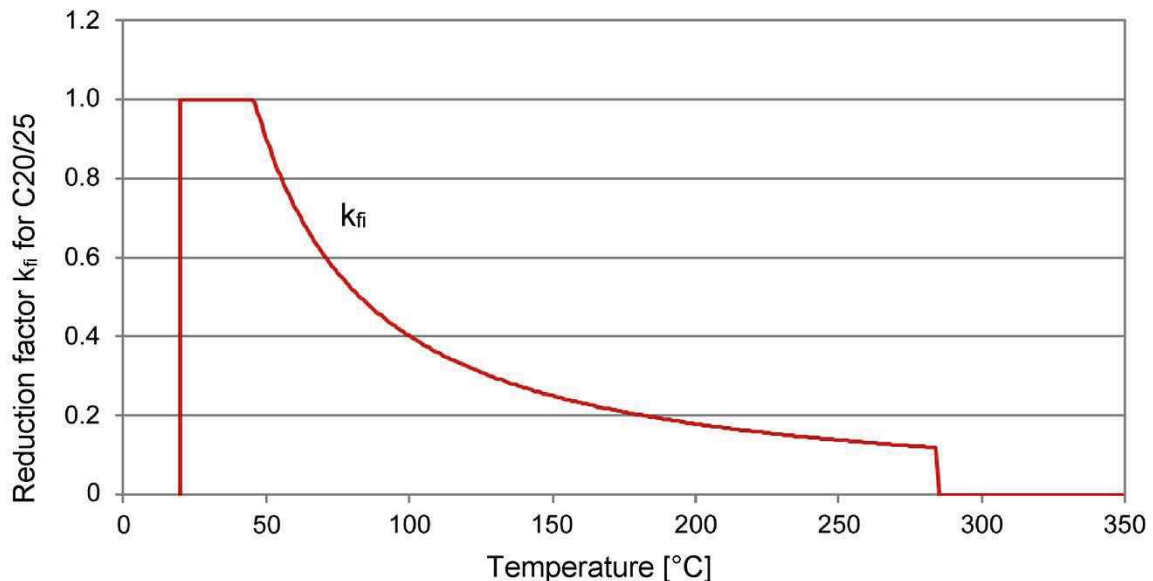

Rebar connection with fischer injection mortar FIS EM Plus

**Performance**  
Bond strength  $f_{bk,fi} = f_{bk,fi,100y}$  at increased temperature

**Annex C5**  
Appendix 24 / 24