

## PRESTANDADECLARATION

### DoP 0306

för Upat Drop-in Anchor USA (Metallankare för användning i betong)

SV

- |  |  |                                |
|--|--|--------------------------------|
| 1. <u>Produkttypens unika identifikationskod:</u>  | <b>DoP 0306</b>  |                                |
| 2. <u>Avsedd användning/avsedda användningar:</u>  | <b>Efterinstallerat fästelement för användning i betong i icke-strukturella system, se bilaga, särskilt bilagor B1-B4.</b> |                                |
| 3. <u>Tillverkare:</u>   | <b>Upat Vertriebs GmbH, Bebelstraße 11, 79108 Freiburg im Breisgau, Tyskland</b>   |                                |
| 4. <u>Tillverkarens representant:</u>  | -  |                                |
| 5. <u>System för bedömning och fortlöpande kontroll av prestanda:</u>  | <b>2+</b>  |                                |
| 6. <u>Europeiskt bedömningsdokument:</u>   | <b>EAD 330747-00-0601, Editin 06/2018</b>  |                                |
| Europeisk teknisk bedömning:   | <b>ETA-10/0168; 2022-05-11</b>   |                                |
| Tekniskt bedömningsorgan:  | <b>DIBt- Deutsches Institut für Bautechnik</b>   |                                |
| Anmält/anmälda organ:  | <b>2873 TU Darmstadt</b>   |                                |
| 7. <u>Angiven prestanda:</u>   |  |                                |
| <b>Säkerhet vid användning (BWR 4)</b>   |  |                                |
| <b>Karakteristisk bärförmåga för spänning (för statisk och kvasi-statisk belastning):</b>                    |  |                                |
| Stålets motståndskraft:  | NPD  |                                |
| Motstånd mot att skruven dras ut:  | NPD  |                                |
| Motstånd i betongkonen:  | NPD  |                                |
| Kraftighet:  | Bilagor C1, C2   |                                |
| Minsta kant- och axelavstånd:  | Bilagor B2, B3, C2   |                                |
| Kantavstånd för att slippa sprickor under last:  | NPD  |                                |
| <b>Karakteristisk bärförmåga för skjuvning (för statisk och kvasi-statisk belastning):</b>                   |  |                                |
| Motstånd i stålet (tvärlast):  | Bilagor C1, C2   | $V_{Rk,s}=NPD; k_{\gamma}=NPD$ |
| Motstånd mot fläkning:   | NPD  |                                |
| Motstånd mot skador i betong:  | NPD  |                                |
| <b>Karakteristisk motståndskraft för laster i alla riktningar och motstånd mot fel. En förenklad design:</b> |  |                                |
| Karakteristisk motståndskraft:   | Bilagor C1, C2   |                                |
| <b>Hållbarhet:</b>   |  |                                |
| Hållbarhet:  | Bilagor A3, B1   |                                |
| <b>Säkerhet vid brand (BWR 2)</b>  |  |                                |
| Reaktion vid brand:  | Klass (A1)   |                                |
| <b>Motståndskraft mot eld:</b>   |  |                                |
| Brandmotstånd i stålet (tvärlast):   | NPD  |                                |
| Brandmotstånd mot utdrag (draglast):   | NPD  |                                |
| Brandmotstånd i stålet (tvärlast):   | Bilaga C3  |                                |
| Brandmotstånd för alla belastningsriktningar och felformer:  | Bilaga C3  |                                |
| 8. <u>Lämplig teknisk dokumentation och/eller särskild teknisk dokumentation:</u>                            | -  |                                |

Prestandan för ovanstående produkt överensstämmer med den angivna prestandan. Denna prestandadeklaration har utfärdats i enlighet med förordning (EU) nr 305/2011 på eget ansvar av den tillverkare som anges ovan.

Undertecknad på tillverkarens vägnar av:



Dr.-Ing. Oliver Geibig, Managing Director Business Units & Engineering  
Tumlingen, 2022-05-25



Jürgen Grün, Managing Director Chemistry & Quality

Denna DoP har förberetts på olika språk. I händelse av tvist om tolkningen ska den engelska versionen alltid råda.

Bilagan innehåller frivilliga och kompletterande information på engelska som överskrider (det specifika språkets) lagkrav.

## Specific Part

### 1 Technical description of the product

The Upat drop-in anchor USA is an anchor made of galvanised or stainless steel which is placed into a drilled hole and anchored by deformation-controlled expansion.

The fixture shall be anchored with a fastening screw or threaded rod according to Annex B 5.

The product description is given in Annex A.

### 2 Specification of the intended use in accordance with the applicable European Assessment Document

The performances given in Section 3 are only valid if the anchor is used in compliance with the specifications and conditions given in Annex B.

The verifications and assessment methods on which this European Technical Assessment is based lead to the assumption of a working life of the anchor of at least 50 years. The indications given on the working life cannot be interpreted as a guarantee given by the producer, but are to be regarded only as a means for choosing the right products in relation to the expected economically reasonable working life of the works.

### 3 Performance of the product and references to the methods used for its assessment

#### 3.1 Safety in case of fire (BWR 2)

Essential characteristic	Performance
Reaction to fire	Class A1
Resistance to fire	See Annex C 3

#### 3.2 Safety and accessibility in use (BWR 4)

Essential characteristic	Performance
Characteristic resistance for all load directions and modes of failure for simplified design	See Annex C 1 and C 2
Durability	See Annex B 1

### 4 Assessment and verification of constancy of performance (AVCP) system applied, with reference to its legal base

In accordance with European Assessment Document EAD No. 330747-00-0601, the applicable European legal act is: [97/161/EC].

The system to be applied is: 2+

**Only for use for redundant non-structural systems according to EN 1992-4:2018**

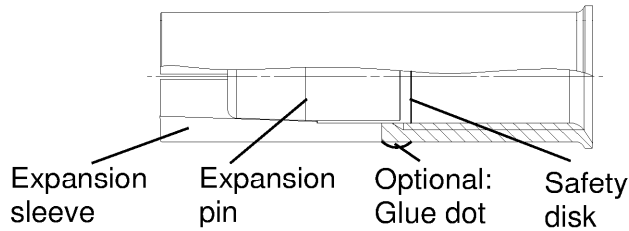
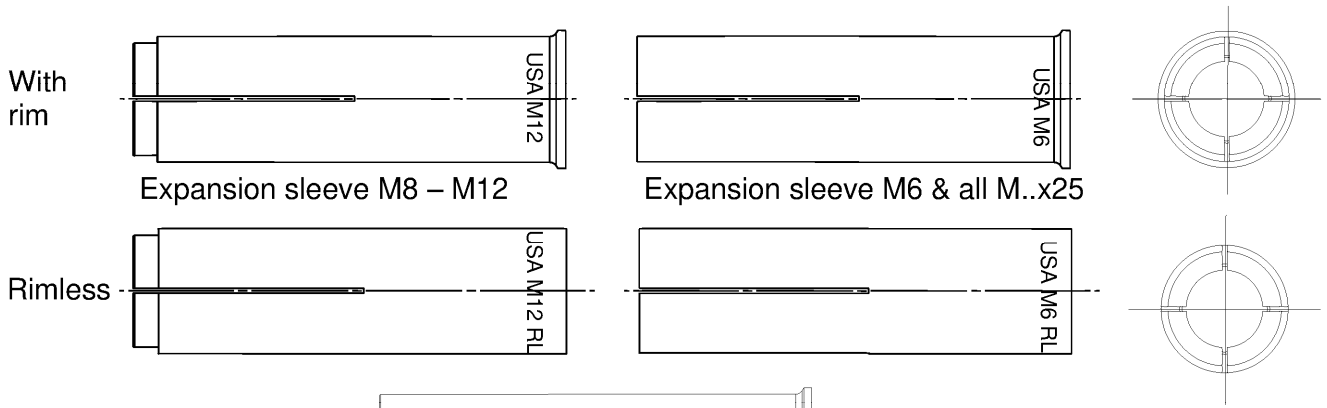

**Intended use in concrete**

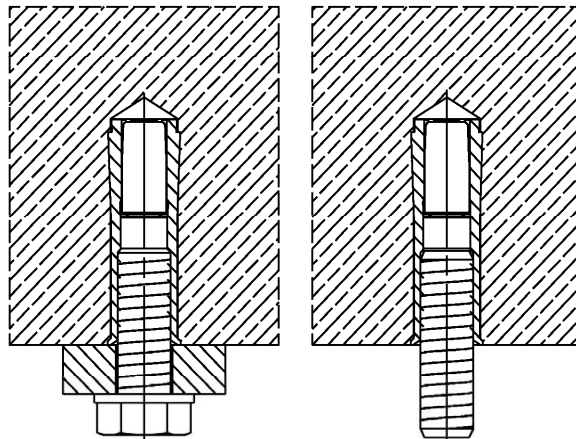

**Intended use in precast pre-stressed hollow concrete slabs ( $w/e \leq 4,2$ ) with a flange thickness  $d_b \geq 35$  mm (or 30 mm → see Annex C2) and only for  $h_{ef} = 25$  mm**

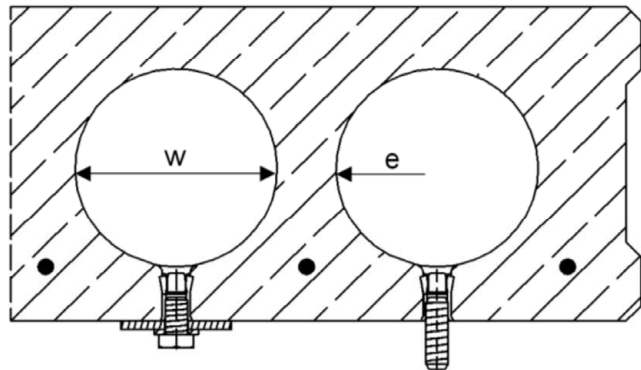

*(Fig. not to scale)*

Upat drop-in anchor USA

**Product description**  
 Installed condition  
 Anchor types

**Annex A 1**

Appendix 2 / 12

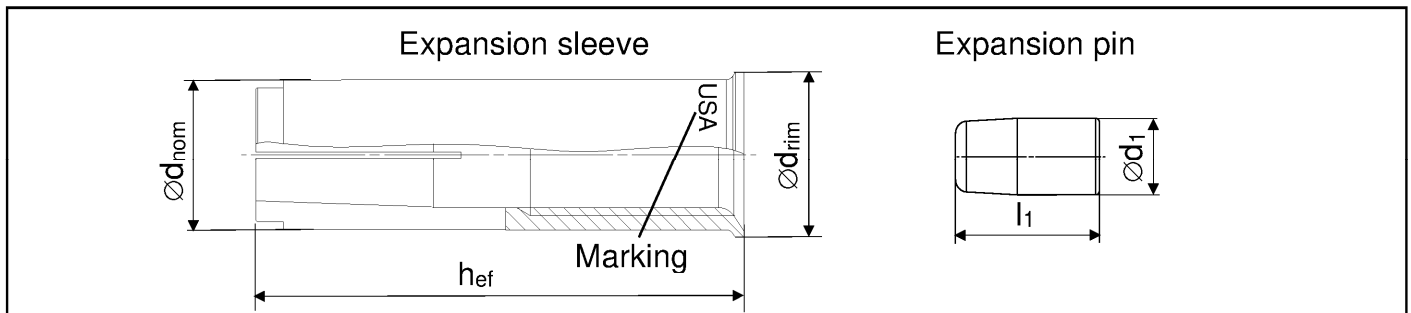

**Table A2.1:** Anchor size

Anchor size USA [mm]	M6x25	M6x30	M8x25	M8x30	M8x40	M10x25	M10x30	M10x40	M12x25	M12x50	M12 D
$h_{ef}$	25	30	25	30	40	25	30	40	25	50	50
$\varnothing d_{nom}$	8		10			12			15		16
$\varnothing d_{rim}$ (not applicable for USA RL)	9,5		11,5			13,5			16,5		17,5
$\varnothing d_1$	5		6,5			8,5	8		10		
$l_1$	9	14	8	13,5		9	13,5	18,5	10,5	18,5	

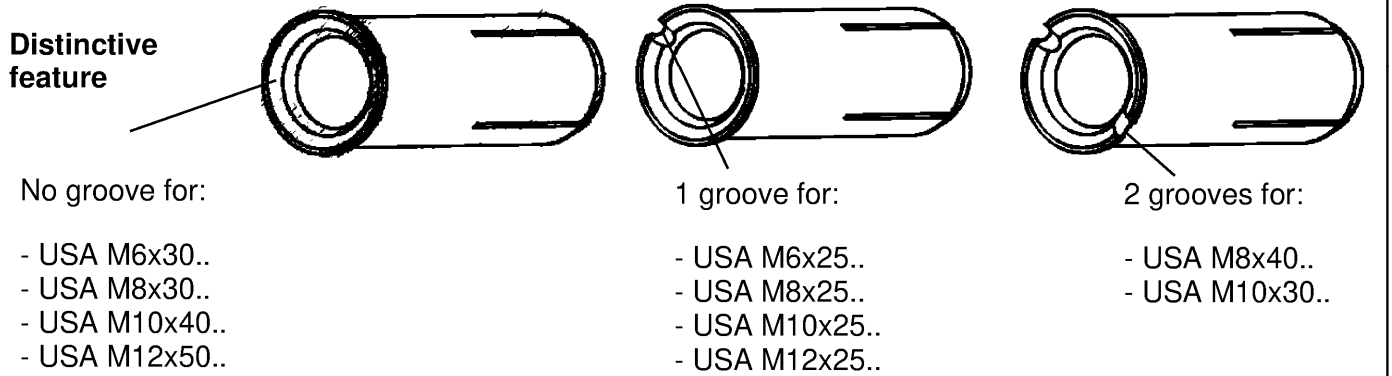

**Table A2.2:** Marking on anchor body

galvanised steel (gvz)		stainless steel (R)	
<i>with rim</i>	<i>rimless</i>	<i>with rim</i>	<i>rimless</i>
USA M6x25	USA M6x25 RL	USA M6x30 R	USA M6x30 RL R
USA M6x30	USA M6x30 RL	USA M8x30 R	USA M8x30 RL R
USA M8x25	USA M8x25 RL	USA M8x40 R	USA M8x40 RL R
USA M8x30	USA M8x30 RL	USA M10x30 R	USA M10x30 RL R
USA M8x40	USA M8x40 RL	USA M10x40 R	USA M10x40 RL R
USA M10x25	USA M10x25 RL	USA M12x50 R	USA M12x50 RL R
USA M10x30	USA M10x30 RL	USA M12x50 D R	USA M12x50 RL D R
USA M10x40	USA M10x40 RL		
USA M12x25	USA M12x25 RL		
USA M12x50	USA M12x50 RL		
USA M12x50 D	USA M12x50 RL D		

(Fig. not to scale)

Upat drop-in anchor USA

**Product description**  
Anchor types

**Annex A 2**

Expansion sleeve

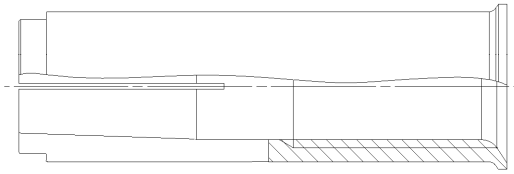

Expansion pin

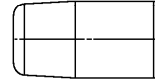
**Table A3.1: Materials**

Designation	Material	
	galvanised steel ( $\geq 5 \mu\text{m}$ )	stainless steel (R)
Expansion sleeve	EN 10277:2018 or EN 10084:2008 or EN 10111:2008 or EN 10263:2018 or EN 10087:1999 or ASTM A29/A29M	EN 10088:2014
Expansion pin		
Fastening screw or threaded rod	steel, property class 4.6, 5.6, 5.8 or 8.8 according to EN ISO 898-1:2013	property class 50, 70 or 80 according EN ISO 3506:2020



Upat drop-in anchor USA

**Product description**  
Materials

**Annex A 3**

Appendix 4 / 12

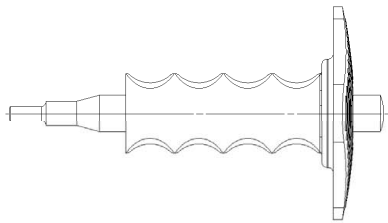
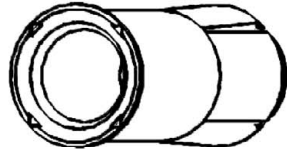
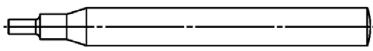
## Setting & drilling tools

Setting tools	Marking	Description	Marking on USA with rim and rimless
	EHS Plus M...x hef	Manual setting tool with hand guard	
	EHS M...x hef	Manual setting tool basic format	
	EMS M...x hef	Machine setting tool with SDS Plus	No marking

### Drilling tools

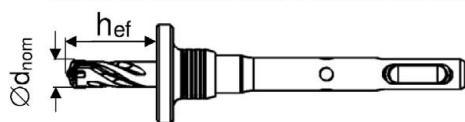

EBB  
 $\varnothing d_{nom} \times h_{ef}$

Stop drill

Or other usual drillers

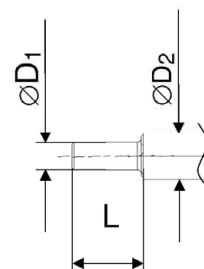

**Table A4.1:** Corresponding drill bits and parameters of setting tools

Manual setting tool	Machine setting tool	Stop drill	For anchor size	$\varnothing D1$ [mm]	$\varnothing D2$ [mm]	L [mm]
EHS (Plus) M6x25/30	EMS M6x25/30	EBB 8x25 EBB 8x30	USA M6x25 USA M6x30	4,8	9,0	17,0
EHS (Plus) M8x25/30	EMS M8x25/30	EBB 10x25 EBB 10x30	USA M8x25 USA M8x30	6,4	11,0	18,0
EHS (Plus) M8x40	EMS M8x40	EBB 10x40	USA M8x40			28,0
EHS (Plus) M10x25/30	EMS M10x25/30	EBB 12x25 EBB 12x30	USA M10x25 USA M10x30	7,9	13,0	18,0
EHS (Plus) M10x40	EMS M10x40	EBB 12x40	USA M10x40			24,0
EHS (Plus) M12x25	EMS M12x25	EBB 15x25	USA M12x25	10,2	16,5	15,2
EHS (Plus) M12x50	EMS M12x50	EBB 15x50	USA M12x50	10,2	16,5	30,0
EHS (Plus) M12x50	EMS M12x50	EBB 16x50	USA M12x50 D			

(Fig. not to scale)

Upat drop-in anchor USA



**Intended Use**  
Setting & Drilling tools

**Annex A 4**

Appendix 5 / 12

## Specifications of intended use

### Anchorage subject to:

Upat drop-in anchor USA (all versions)	M6	M8	M10	M12
Hammer drilling with standard drill bit 	All types			
Hammer drilling with hollow drill bit with automatic cleaning 				
Material	Steel	Zinc plated		
	Stainless steel	R		
Static and quasi-static loads	✓			
Cracked and uncracked concrete				
Fire exposure in concrete C12/15 to C50/60				
Fire exposure in prestressed hollow concrete slabs	No performance assessed			

#### Base materials:

- Compacted reinforced and unreinforced normal weight concrete without fibres (cracked and uncracked) according to EN 206:2013+A1:2016
- Strength classes C12/15 to C50/60 according to EN 206:2013+A1:2016
- Precast prestressed hollow concrete slabs with  $w/e \leq 4,2$  and strength classes C30/37 to C50/60: M6x25, M8x25, M10x25 and M12x25

#### Use conditions (Environmental conditions):

- Structures subject to dry internal conditions: **USA, USA R**
- For all other conditions according to EN 1993-1-4:2006 + A1:2015 corresponding to corrosion resistance class CRC III **USA R with  $h_{ef} \geq 30$  mm**

#### Design:

- Anchorages are designed under the responsibility of an engineer experienced in anchorages and concrete work
- Verifiable calculation notes and drawings are prepared taking account of the loads to be anchored. The position of the anchor is indicated on the design drawings (e. g. position of the anchor relative to reinforcement or to supports, etc.)
- Only for use for redundant non-structural system according to EN 1992-4:2018, Chapter 7.3. Design Method B according to EN 1992-4:2018.
- Anchorages under fire exposure are designed according to EN 1992-4:2018 Annex D

#### Installation:

- Anchor installation carried out by appropriately qualified personnel and under the supervision of the person responsible for technical matters of the site
- Create drill hole with hammer drill or with hollow drill and vacuum cleaner
- The anchor may only be used once
- In case of aborted hole: New hole must be drilled at a minimum distance of twice the depth of the aborted hole or closer, if the hole is filled with a high strength mortar (e.g. UPM 66, UPM 55 or UPM 44) and only if the hole is not in the direction of the oblique tensile or shear load
- Anchor expansion by impact using the setting tools given in Annex A 4. The anchor is properly set, if the stop of the setting tool reaches the expansion sleeve. The manual setting tool with installation control leaves a visible mark on the sleeve, as illustrated in Annex A 4 and B 4

Upat drop-in anchor USA

**Intended Use**  
Specifications

**Annex B 1**

Appendix 6 / 12

**Table B2.1:** Installation parameters for concrete C12/15 to C50/60

Anchor size (all versions)			M6		M8			M10			M12		M12D
Nominal drill hole diameter	$d_0$	[mm]	8		10			12			15		16
Effective anchorage depth	$h_{ef}$	[mm]	25	30	25	30	40	25	30	40	25	50	50
Maximum installation torque	$T_{inst,max}$	[Nm]	4		8			15			35		
Minimum drill hole depth	$h_1$	[mm]	27	32	27	33	43	27	33	43	27	54	54
Minimum screw-in depth	$l_{s,min}$	[mm]	6		8			10			12		
Maximum screw-in depth	$l_{s,max}$	[mm]	14		14			14	15	17	14	22	
Clearance hole diameter	$\varnothing d_f \leq$	[mm]	7		9			12			14		
<b><math>h_{min} = 80</math> mm</b>													
Minimum spacing	$s_{min}$	[mm]	30	70	70	110	200	80	200		100	-	-
Minimum edge distance	$c_{min}$	[mm]	60	150	100	150		120	150		130	-	-
<b><math>h_{min} = 100</math> mm</b>													
Minimum spacing	$s_{min}$	[mm]	30	65	50	70	60	90	150	100	200		
Minimum edge distance	$c_{min}$	[mm]	60	115	100	115	100	160	180	110			
<b><math>h_{min} = 120</math> mm</b>													
Minimum spacing	$s_{min}$	[mm]	30	65	50	70	60	85	95	100	145		
Minimum edge distance	$c_{min}$	[mm]	60	115	100	115	100	140	150	110	200		

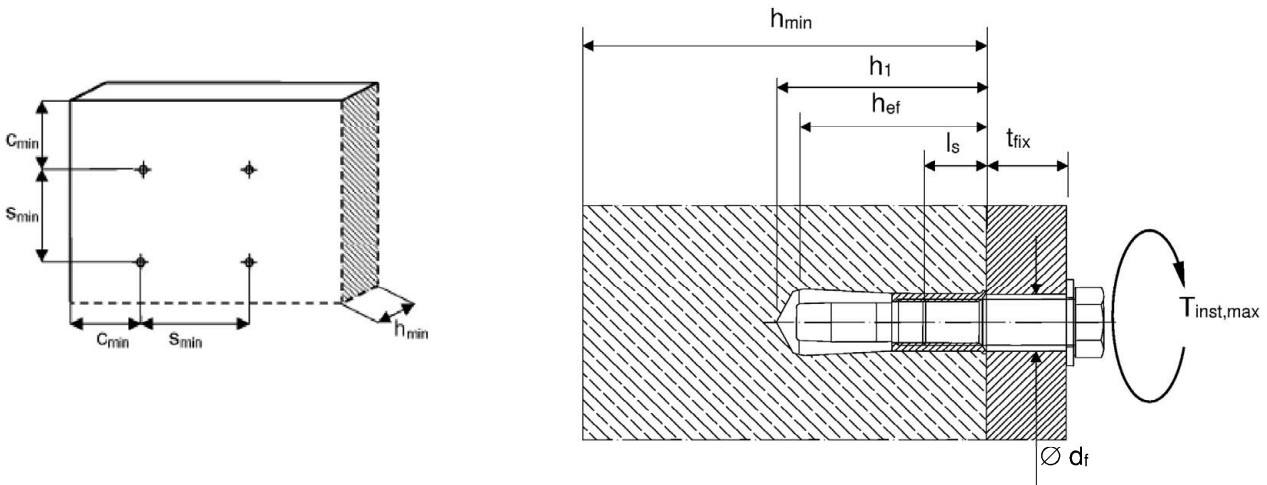

Fastening screw or threaded rod:

- Minimum property class and materials according to table A3.1
- The length of the fastening screw or threaded rod shall be determined depending on thickness of fixture  $t_{fix}$ , admissible tolerances and maximum screw-in depth  $l_{s,max}$  as well as minimum screw-in depth  $l_{s,min}$ .

(Fig. not to scale)

Upat drop-in anchor USA

**Intended Use**  
Installation parameters

**Annex B 2**

Appendix 7 / 12



**Table B3.1:** Installation parameters for precast pre-stressed hollow concrete slabs

Anchor size (all versions)			M6	M8	M10	M12
Nominal drill hole diameter	$d_0$	[mm]	8	10	12	15
Effective anchorage depth	$h_{ef}$	[mm]	25			
Maximum installation torque	$T_{inst,max}$	[Nm]	4	8	15	35
Minimum drill hole depth	$h_1$	[mm]	27			
Minimum screw-in depth	$l_{s,min}$	[mm]	6	8	10	12
Maximum screw-in depth	$l_{s,max}$	[mm]	14			
Clearance hole diameter	$\varnothing d_f$	[mm]	7	9	12	14
Minimum spacing	$s_{min} = s_{cr}$	[mm]	200			
Minimum edge distance	$c_{min} = c_{cr}$	[mm]	150			

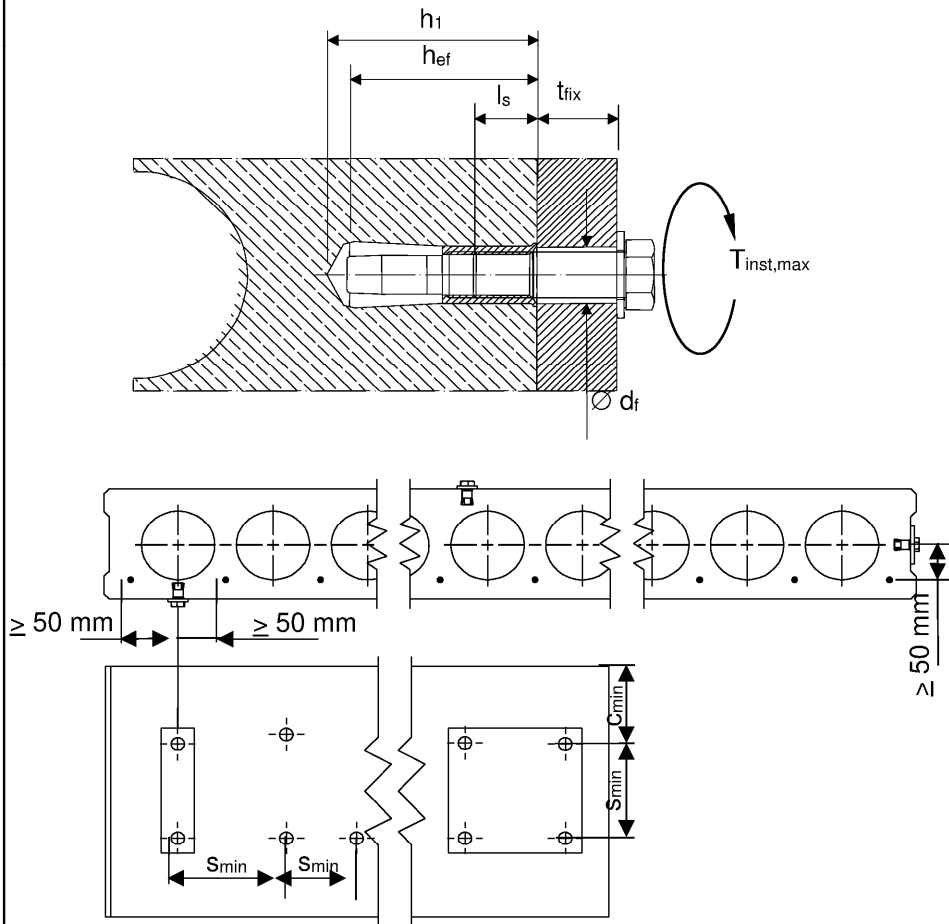

Fastening screw or threaded rod:

- Minimum property class and materials according to table A3.1
- The length of the fastening screw or threaded rod shall be determined depending on thickness of fixture  $t_{fix}$ , admissible tolerances and maximum screw-in depth  $l_{s,max}$  as well as minimum screw-in depth  $l_{s,min}$ .

(Fig. not to scale)

Upat drop-in anchor USA

**Intended Use**  
Installation parameters

**Annex B 3**

Appendix 8 / 12

# Installation instructions

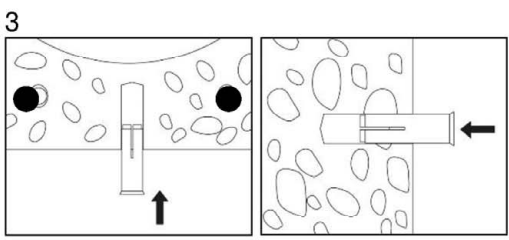
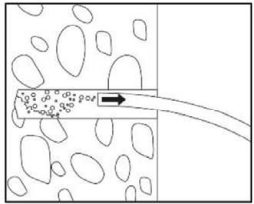
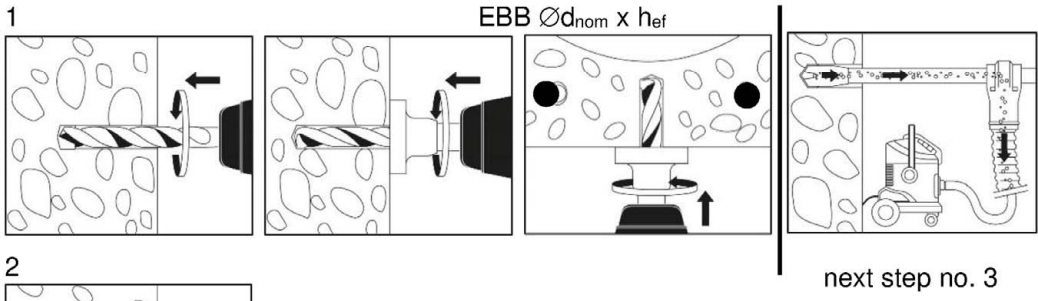

**Fixing is not allowed for  $h_{ef} = 25 \text{ mm}$  and  $d_b < 35 \text{ mm}$  when a cavity is cut!**

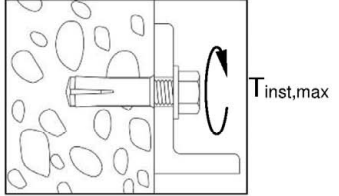
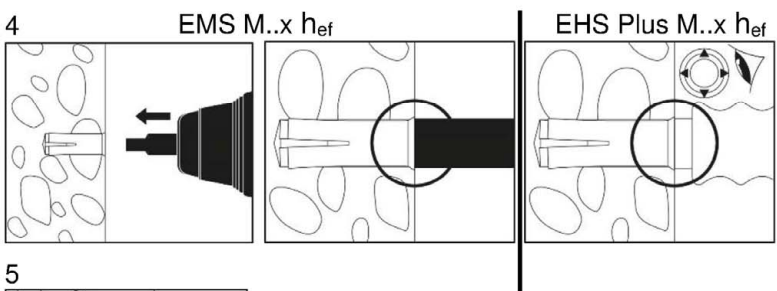
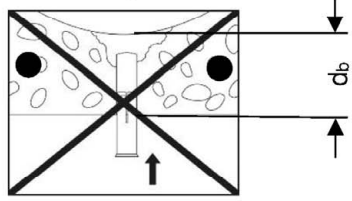

No.	Description
1	Create drill hole with hammer drill or stop drill or with hollow drill and vacuum cleaner
2	Clean from drill-dust
3	Set anchor till anchor is flush with surface of concrete
4	Expand the sleeve by driving the pin with the corresponding setting tool into the sleeve and control the correct setting
5	Fixation of fixture. Maximum installation torque $T_{inst,max}$ must not be exceeded

(Fig. not to scale)

<b>Upat drop-in anchor USA</b>	<b>Annex B 4</b> Appendix 9 / 12
<b>Intended Use</b> Installation instructions	

**Table C1.1:** Characteristic resistance of a fixing point<sup>1)</sup> for all load directions

Anchor size		property class of the fastening screw or threaded rod	M6		M8			M10			M12/M12D	
Effective anchorage depth	$h_{ef}$ [mm]		25	30	25	30	40	25	30	40	25	50
<b>All load directions</b>												
Characteristic resistance C12/15	$F_{0RK}$ [kN]	$\geq$ A4-50	<sup>-2)</sup>	2	<sup>-2)</sup>	3	<sup>-2)</sup>	3	5	<sup>-2)</sup>	6	
		$\geq$ steel 4.6	1,5	2	3	3	5	3	6			
Characteristic resistance C20/25 to C50/60	$F_{0RK}$ [kN]	$\geq$ A4-50	<sup>-2)</sup>	3	<sup>-2)</sup>	5	<sup>-2)</sup>	5	7,5	<sup>-2)</sup>	9	
		$\geq$ steel 4.6	2	3	5	4	7,5	4	9			
Installation factor	$\gamma_{inst}$ [-]		1,0	1,2	1,0	1,2	1,0	1,2	1,0	1,0		
Characteristic spacing	$s_{cr}$ [mm]		75	90	75	90	120	75	90	200	75	300
Characteristic edge distance	$c_{cr}$ [mm]		38	45	38	45	60	38	45	100	38	150
<b>Steel failure with lever arm</b>												
Characteristic resistance	$M_{0RK,s}^0$ [Nm]	A4-50	<sup>-2)</sup>	8	<sup>-2)</sup>	19	<sup>-2)</sup>	37	<sup>-2)</sup>	66		
Partial factor	$\gamma_{Ms^{(3)}}$ [-]		2,38									
Characteristic resistance	$M_{0RK,s}^0$ [Nm]	A4-70	<sup>-2)</sup>	11	<sup>-2)</sup>	26	<sup>-2)</sup>	52	<sup>-2)</sup>	92		
Partial factor	$\gamma_{Ms^{(3)}}$ [-]		1,56									
Characteristic resistance	$M_{0RK,s}^0$ [Nm]	A4-80	<sup>-2)</sup>	12	<sup>-2)</sup>	30	<sup>-2)</sup>	60	<sup>-2)</sup>	105		
Partial factor	$\gamma_{Ms^{(3)}}$ [-]		1,33									
Characteristic resistance	$M_{0RK,s}^0$ [Nm]	steel 4.6	6,1		15			30		52		
Partial factor	$\gamma_{Ms^{(3)}}$ [-]		1,67									
Characteristic resistance	$M_{0RK,s}^0$ [Nm]	steel 5.6	7,6		19			37		66		
Partial factor	$\gamma_{Ms^{(3)}}$ [-]		1,67									
Characteristic resistance	$M_{0RK,s}^0$ [Nm]	steel 5.8	7,6		19			37		66		
Partial factor	$\gamma_{Ms^{(3)}}$ [-]		1,25									
Characteristic resistance	$M_{0RK,s}^0$ [Nm]	steel 8.8	12		30			60		105		
Partial factor	$\gamma_{Ms^{(3)}}$ [-]		1,25									

1) For definition see EN 1992-4:2018, Picture 3.4

2) No performance assessed

3) In absence of other national regulations

## Upat drop-in anchor USA

### Performances

Characteristic values for tension loads in concrete according to design method B

## Annex C 1

Appendix 10 / 12

**Table C2.1:** Characteristic values for  $h_{ef} = 25$  mm in precast pre-stressed hollow concrete slabs according to design method C with C30/37 to C50/60

Anchor size		property class of the fastening screw or threaded rod	M6	M8	M10	M12
Effective anchorage depth	$h_{ef}$ [mm]			25		
<b>All Load directions</b>			galvanised steel; with rim			
Flange thickness	$d_b$ [mm]		$\geq 35$ (or $30^{1)}$ )			
Characteristic resistance C30/37 to C50/60	$F^{0}_{RK}$ [kN]		2	3	4	
Installation factor	$\gamma_{inst}$ [-]		1,0			
Characteristic spacing	$S_{cr} = S_{min}$ [mm]		200			
Characteristic edge distance	$C_{cr} = C_{min}$ [mm]		150			
<b>Steel failure with lever arm</b>						
Characteristic resistance	$M^{0}_{RK,s}$ [Nm]	steel 4.6	6,1	15	30	52
Partial factor	$\gamma_{Ms^{2)}$ [-]		1,67			
Characteristic resistance	$M^{0}_{RK,s}$ [Nm]	steel 5.6	7,6	19	37	66
Partial factor	$\gamma_{Ms^{2)}$ [-]		1,67			
Characteristic resistance	$M^{0}_{RK,s}$ [Nm]	steel 5.8	7,6	19	37	66
Partial factor	$\gamma_{Ms^{2)}$ [-]		1,25			
Characteristic resistance	$M^{0}_{RK,s}$ [Nm]	steel 8.8	12	30	60	105
Partial factor	$\gamma_{Ms^{2)}$ [-]		1,25			

<sup>1)</sup> The anchor may be used in a flange thickness  $d_b$  of minimum 30 mm with the same characteristic resistance, but the drill hole is not allowed to cut a cavity (see Annex B 4 Point 3). The use of the fischer stop drill EBB is recommended

<sup>2)</sup> In absence of other national regulations

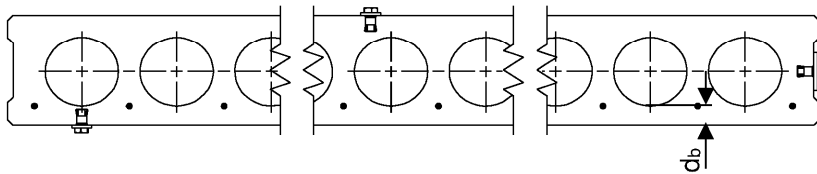

(Fig. not to scale)

Upat drop-in anchor USA

**Performances**

Characteristic values for tension loads in hollow core slabs according to design method C with C30/37 to C50/60

**Annex C 2**

Appendix 11 / 12

**Table C3.1:** Characteristic resistance under fire exposure<sup>3)</sup> in concrete C20/25 to C50/60

fire resistance class	USA	property class of the fastening screw or threaded rod	M6x25	M6x30	M8x25	M8x30	M8x40	M10x25	M10x30	M10x40	M12x25	M12x50/ M12x50D
R 30	Characteristic resistance C20/25 to C50/60	F <sup>0</sup> <sub>Rk,fi</sub> <sup>1)</sup> [kN]	steel ≥ 4.6 or ≥ A4-50 <sup>2)</sup>	0,5	0,6	0,9	1,3	0,6	0,9	1,8	0,6	2,3
R 60				0,5	0,6	0,9	1,5					
R 90				0,4	0,6			0,9		2,0		
R 120				0,3	0,5			0,6	0,5	1,3		
R 30 – R 120	Characteristic spacing	S <sub>cr,fi</sub> [mm]	100	120	100	120	160	100	120	160	100	200
	Characteristic edge distance	C <sub>cr,fi</sub> [mm]	50	115	50	140	140	50	140	160	50	

<sup>1)</sup> In absence of other national regulations, a partial factor for the resistance of  $\gamma_{m,fi} = 1,0$  under fire impact is recommended.

<sup>2)</sup> Not for M..x25

<sup>3)</sup> Not valid for precast pre-stressed hollow core slabs

**Table C3.2:** Characteristic resistance under fire exposure<sup>3)</sup> for shear load with level arm in concrete C20/25 to C50/60

fire resistance class	USA	property class of the fastening screw or threaded rod	M6x25	M6x30	M8x25	M8x30	M8x40	M10x25	M10x30	M10x40	M12x25	M12x50/ M12x50D
R 60	0,50	0,4	0,95	1,3	1,3	1,7	3,2	3,2	5,0	6,7		
R 90	0,35	0,3	0,60	0,8	0,8	1,0	1,9	1,9	2,9	3,9		
R 120	0,30	0,2	0,45	0,6	0,6	0,7	1,3	1,3	1,8	2,4		

<sup>1)</sup> In absence of other national regulations, a partial factor for the resistance of  $\gamma_{m,fi} = 1,0$  under fire impact is recommended.

<sup>2)</sup> Not for M..x25

<sup>3)</sup> Not valid for precast pre-stressed hollow core slabs

In case of fire attack from more than one side, the edge distance shall be  $c_{fi,min} \geq 300$  mm

**Upat drop-in anchor USA**

**Performances**

Characteristic loads for fire resistances

**Annex C 3**