



PRESTANDEDEKLARATION

DoP 0241

för Upats fasadplugg URD (Plastankare för användning i betong och murverk)

SV

1. Produkttypens unika identifikationskod: DoP 0241
2. Avsedd användning/avsedda användningar: **Plastankare för flera användningsområden i icke-strukturell betong och murverk (användningskategori a, b, c, d);, se bilaga, särskilt bilagor B1 - B4.**
3. Tillverkare: **Upat Vertriebs GmbH, Bebelstraße 11, 79108 Freiburg im Breisgau, Tyskland**
4. Tillverkarens representant: -
5. System för bedömning och fortlöpande kontroll av prestanda: **2+**
6. Europeiskt bedömningsdokument: **ETAG020, 2012-03, används som EAD**
Europeisk teknisk bedömning: **ETA-17/0811; 2021-05-25**
Tekniskt bedömningsorgan: **DIBt- Deutsches Institut für Bautechnik**
Anmält/anmälda organ: **2873 TU Darmstadt**
7. Angiven prestanda:
Mekanisk hållfasthet och stabilitet (BWR 1)
Motstånd mot skador i stålet under draglast: Bilaga C1
Motstånd mot skador i stål eller polymer under tvärlast: Bilaga C1
Motstånd mot att det dras ut eller betongen skadas under draglast (basmaterialgrupp a): Bilaga C1

Motstånd i alla lastriktningar utan hävarm (basmaterialgrupp b, c och d): Bilagor C3 - C14
Kant- och inbördes avstånd (basmaterialgrupp a): Bilaga B2
Kant- och inbördes avstånd (basmaterialgrupp b, c och d): Bilaga B3
Förflyttningar under kort- och långvarig belastning: Bilaga C2
Hållbarhet: Bilagor A3, B1

Säkerhet vid brand (BWR 2)
Reaktion vid brand: Klass A1
Motståndskraft mot eld: Bilaga C2
8. Lämplig teknisk dokumentation och/eller särskild teknisk dokumentation: -

Prestandan för ovanstående produkt överensstämmer med den angivna prestandan. Denna prestandadeklaration har utfärdats i enlighet med förordning (EU) nr 305/2011 på eget ansvar av den tillverkare som anges ovan.

Undertecknad på tillverkarens vägnar av:

Dr.-Ing. Oliver Geibig, Verkställande direktör affärsenheter och teknik
Tumlingen, 2021-06-01

Jürgen Grün, Verkställande direktör kemi och kvalitet

Denna DoP har förberetts på olika språk. I händelse av tvist om tolkningen ska den engelska versionen alltid råda.

Bilagan innehåller frivilliga och kompletterande information på engelska som överskrider (det specifika språkets) lagkrav.

Specific Part

1 Technical description of the product

The frame fixing in the range URD 8 and URD 10 is a plastic anchor consisting of a plastic sleeve made of polyamide and an accompanying specific screw of galvanised steel, of galvanised steel with an additional organic layer or of stainless steel.

The plastic sleeve is expanded by screwing in the specific screw which presses the sleeve against the wall of the drilled hole.

The product description is given in Annex A.

2 Specification of the intended use in accordance with the applicable European Assessment Document

The performances given in Section 3 are only valid if the anchor is used in compliance with the specifications and conditions given in Annex B.

The verifications and assessment methods on which this European Technical Assessment is based lead to the assumption of a working life of the anchors of at least 50 years. The indications given on the working life cannot be interpreted as a guarantee given by the producer, but are to be regarded only as a means for choosing the right products in relation to the expected economically reasonable working life of the works.

3 Performance of the product and references to the methods used for its assessment

3.1 Safety in case of fire (BWR 2)

Essential characteristic	Performance
Reaction to fire	Class A 1
Resistance to fire	See Annex C 2

3.2 Safety and accessibility (BWR 4)

Essential characteristic	Performance
Characteristic resistance for tension and shear loads	See Annexes C 1, C 3 – C 14
Edge distance and spacing	See Annex B 2, B 3
Displacements	See Annex C 2
Durability	See Annex B 1

4 Assessment and verification of constancy of performance (AVCP) system applied, with reference to its legal base

In accordance with guideline for European technical approval ETAG 020, March 2012 used as European Assessment Document (EAD) according to Article 66 Paragraph 3 of Regulation (EU) No 305/2011 the applicable European legal act is: 97/463/EC.

The system to be applied is: 2+

URD

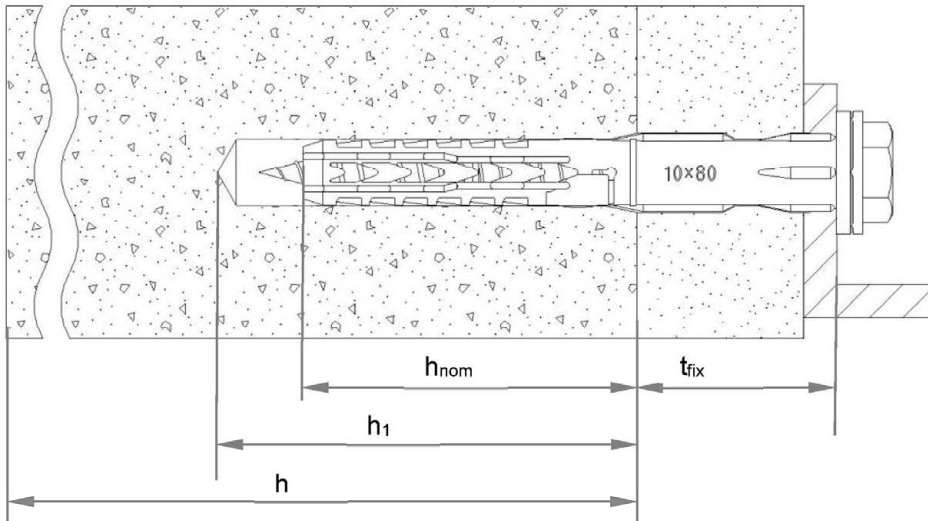

Legend

- h_{nom} = overall plastic anchor embedment depth in the base material
- h_1 = depth of drill hole to deepest point
- h = thickness of member (wall)
- t_{fix} = thickness of fixture and / or non-load bearing layer

frame fixing URD

Product description
Installed anchor

Annex A 1

Appendix 2 / 22

Anchor sleeves – flat collar version of URD

URD-version

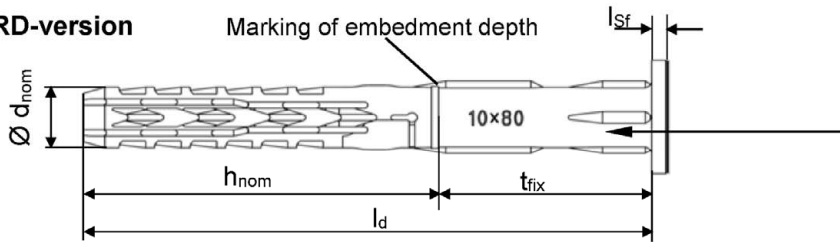

Marking:
Brand
Anchor type
Size
e.g. URD 10x80

Countersunk sleeve version also available



Countersunk screws

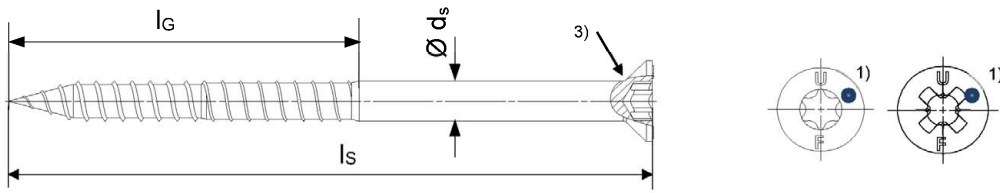

Hexagonal screw with washer

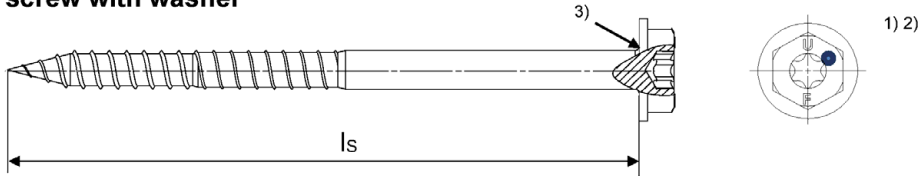

Hexagonal screw

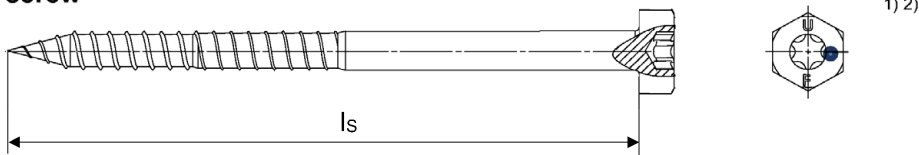

Stud screw

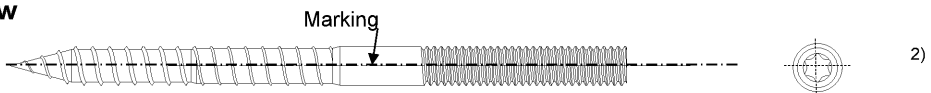

- 1) Additional marking for the special screw, stainless steel version: „A4“ or “R”
- 2) Internal driving feature for Torx bit is optional for hexagonal head and for stud screw
- 3) Optional additional version with underhead ribs

frame fixing URD

Product description
Anchor types / special screws

Annex A 2

Table A3.1: Dimensions [mm]

Anchor type	Anchor sleeve							Special screw		
	h_{nom} [mm]	$\varnothing d_{nom}$ [mm]	t_{fix} [mm]	min. l_d [mm]	max. l_d [mm]	$l_{sf}^{1)}$ [mm]	$\varnothing d_{sf}$ [mm]	$\varnothing d_s$ [mm]	l_G [mm]	l_s [mm]
URD 8	50	8	≥ 1	51	360	1,8	> 15,0	6,0	≥ 55	$\geq l_d + 6$
URD 10	50	10	≥ 1	51	360	2,2	> 18,5	7,0	≥ 57	$\geq l_d + 7$

¹⁾ Only valid for flat collar version

Table A3.2: Materials

Name	Material
Anchor sleeve	Polyamide, PA6, colours: grey, off-white
Special screw	<ul style="list-style-type: none"> - Galvanized steel gvz with Zn5/Ag or Zn5/An in accordance with EN ISO 4042:2018 <li style="text-align: center;">or - Galvanized steel gvz with Zn5/Ag or Zn5/An in accordance with EN ISO 4042:2018 with additional organic layer (Zn5/Ag/T7 or Zn5/An/T7, resp.) in three layers (total layer thickness $\geq 6 \mu\text{m}$) <li style="text-align: center;">or - Stainless steel of corrosion resistance class CRC III in accordance with EN 1993-1-4:2006 + A1:2015

frame fixing URD

Product description
Dimensions and materials

Annex A 3

Appendix 4 / 22

Specifications of intended use

Anchorage subject to:

- Static and quasi-static loads.
- Multiple fixing of non-structural applications.

Base materials:

- Reinforced or unreinforced normal weight concrete with strength classes \geq C12/15 (use category “a”), according to EN 206-1:2000, Annex C 1, C 2.
- Solid brick masonry (use category “b”), according to Annex C 3 – C 5.
Note: The characteristic resistance is also valid for larger brick sizes and higher compressive strength of the masonry unit.
- Hollow brick masonry (use category “c”), according to Annex C 6 – C 13.
- Autoclaved aerated concrete (use category “d”), according to Annex C 14.
- Mortar strength class of the masonry \geq M2,5 according to EN 998-2:2010.
- For other base materials of the use categories “a”, “b”, “c” and “d” the characteristic resistance of the anchor may be determined by job site tests according to ETAG 020, Annex B, Edition March 2012.

Temperature Range:

URD 8 and 10

- c: - 40 °C to 50 °C (max. short term temperature + 50 °C and max long term temperature + 30 °C)
- b: - 40 °C to 80 °C (max. short term temperature + 80 °C and max long term temperature + 50 °C)

Use conditions (Environmental conditions):

- Structures subject to dry internal conditions (zinc coated steel, stainless steel).
- The specific screw made of galvanised steel or galvanised steel with an additional organic layer may also be used in structures subject to external atmospheric exposure, if the area of the head of the screw is protected against moisture and driving rain after mounting of the fixing unit in this way, that intrusion of moisture into the anchor shaft is prevented. Therefore there shall be an external cladding or a ventilated rainscreen mounted in front of the head of the screw and the head of the screw itself shall be coated with a soft plastic, permanently elastic bitumen-oil-combination coating (e.g. undercoating or body cavity protection for cars).
- Structures subject to external atmospheric exposure (including industrial and marine environment) and to permanently damp internal condition, if no particular aggressive conditions exist (stainless steel).
Note: Particular aggressive conditions are e.g. permanent, alternating immersion in seawater or the splash zone of seawater, chloride atmosphere of indoor swimming pools or atmosphere with extreme chemical pollution (e.g. in desulphurization plants or road tunnels where de-icing materials are used).

Design:

- The anchorages are to be designed in accordance with the ETAG 020, Annex C under the responsibility of an engineer experienced in anchorages and masonry work.
- Verifiable calculation notes and drawings shall be prepared taking account of the loads to be anchored, the nature and strength of the base materials and the dimensions of the anchorage members as well as of the relevant tolerances. The position of the anchor is indicated on the design drawings.
- Fasteners are only to be used for multiple use for non-structural application, according to ETAG 020, Edition March 2012.

Installation:

- Hole drilling by the drilling method according to Annex C 1, C 3 – C 14 for use categories “b”, “c” and “d”.
- Anchor installation carried out by appropriately qualified personnel and under the supervision of the person responsible for technical matters of the site.
- Installation temperature from URD 8 and URD 10: - 5 °C to + 40 °C
- Exposure to UV due to solar radiation of the not protected anchor \leq 6 weeks.

frame fixing URD

Intended use
Specifications

Annex B 1

Appendix 5 / 22

Table B2.1: Installation parameters

Anchor type		URD 8	URD 10
Drill hole diameter	$d_0 =$ [mm]	8	10
Cutting diameter of drill bit	$d_{cut} \leq$ [mm]	8,45	10,45
Overall plastic anchor embedment depth in the base material ¹⁾	$h_{nom} \geq$ [mm]	50	50
Depth of drill hole to deepest point ¹⁾	$h_1 \geq$ [mm]	60	60
Diameter of clearance hole in the fixture	$d_f \leq$ [mm]	8,5	10,5/12,5 ²⁾

¹⁾ For hollow and perforated masonry: If the embedment depth is higher than h_{nom} given in the Table B2.1, job site tests have to be carried out according to ETAG 020, Annex B.

²⁾ See Table C2.1.

Table B2.2: Assignment of h_{nom} , l_d and t_{fix} for use in thin concrete slabs (e.g. weather resistant shells of external wall panels)

Anchor type	URD 10		
Use category "a" 	$h_{nom} \geq 50$ mm		
	l_d	$t_{fix, min}$	$t_{fix, max}$
	52	1	2
	60	1	10
	80	21	30
	100	41	50
	120	61	70
	140	81	90
	160	101	110
	180	121	130
	200	141	150
	230	171	180
	260	201	210
		[mm]	

Table B2.3: Minimum thickness of member, edge distance and spacing in concrete

Anchor Type	$h_{nom} \geq$ [mm]	Strength class	Min. thickness of member h_{min} [mm]	Characteristic edge distance $c_{cr,N}$ [mm]	Characteristic spacing $s_{cr,N}$ [mm]	Min. spacing and edge distances ¹⁾ [mm]
URD 8	50	\geq C16/20	100	60	70	$s_{min} = 70$ for $c \geq 60$ $c_{min} = 60$ for $s \geq 70$
		C12/15		85	100	$s_{min} = 100$ for $c \geq 85$ $c_{min} = 85$ for $s \geq 100$
URD 10	50	\geq C16/20	100 ²⁾	100	90	$s_{min} = 50$ for $c \geq 150$ $c_{min} = 60$ for $s \geq 70$
		C12/15		140	100	$s_{min} = 70$ for $c \geq 210$ $c_{min} = 85$ for $s \geq 100$

¹⁾ Intermediate values by linear interpolation.

²⁾ Also valid for thin concrete slabs $h \geq 40$ mm, $h_{nom} = 50$ mm to 59 mm

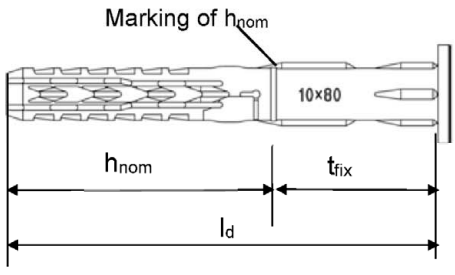
Fixing points with a spacing $a \leq s_{cr,N}$ are considered as a group with a max. characteristic resistance $N_{RK,p}$ acc. to Table C1.3. For a spacing $a > s_{cr,N}$ the anchors are considered as single anchors, each with a characteristic resistance $N_{RK,p}$ acc. to Table C1.3.

frame fixing URD	Annex B 2 Appendix 6 / 22
Intended use Installation parameters, parameters for use in thin e.g. weather resistant concrete skins Member thickness, distance and spacing in concrete	

Table B3.1: Minimum thickness of member, edge distance and spacing in masonry

Anchor type		URD 8	URD 10
Minimum thickness of member	h_{min} [mm]	100	100
Single anchor			
Minimum spacing	a_{min} [mm]	250	250
Minimum edge distance	c_{min} [mm]	100	100
Anchor group			
Minimum spacing perpendicular to free edge	$s_{1,min}$ [mm]	100	100
Minimum spacing parallel to free edge	$s_{2,min}$ [mm]	100	100
Minimum edge distance	c_{min} [mm]	100	100
Distance between anchor groups and / or single anchors	a [mm]	250	

Table B3.2: Minimum thickness of member, edge distance, spacing in autoclaved aerated concrete

Anchor type		URD 10
Compressive strength	f_{ck} [N/mm ²]	≥ 2
Nominal embedment depth	$h_{nom} \geq$ [mm]	50
Minimum thickness of member	h_{min} [mm]	100
Single anchor		
Minimum spacing	a_{min} [mm]	250
Minimum edge distance	c_{min} [mm]	100
Anchor group		
Minimum spacing perpendicular to free edge	$s_{1,min}$ [mm]	200
Minimum spacing parallel to free edge	$s_{2,min}$ [mm]	400
Minimum edge distance	c_{min} [mm]	100
Distance between anchor groups and / or single anchors	a [mm]	400

Scheme of distance and spacing in concrete

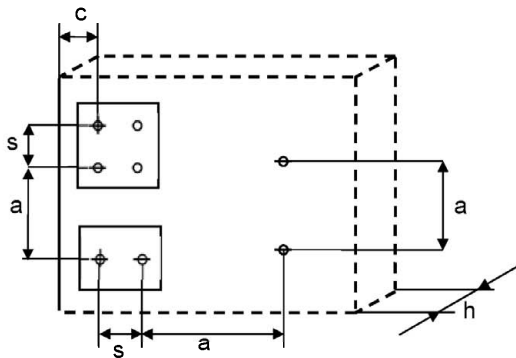

Scheme of distance and spacing in masonry and autoclaved aerated concrete

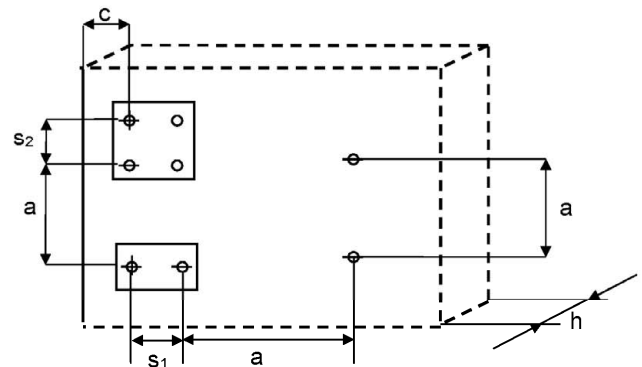

frame fixing URD

Intended use

Member thickness, distance and spacing in masonry and autoclaved aerated concrete, schemes of distance and spacing in concrete, masonry and autoclaved aerated concrete

Annex B 3

Installation instructions (the following pictures show fixing through timber)

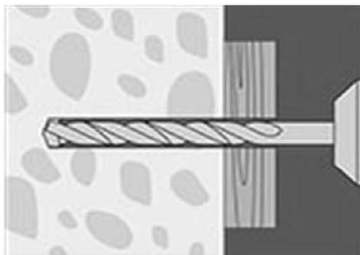

1. Drill the bore hole acc. to Table B2.1 using the drill method described in the corresponding Annex C.



2. Use category „a“ concrete, „b“ solid masonry, „d“ autoclaved aerated concrete: Remove dust from borehole.

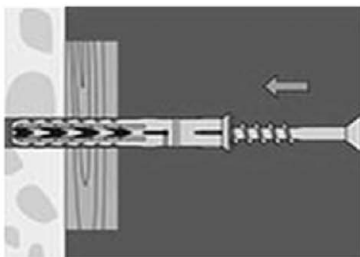

3. Insert anchor (screw and plug) by using a hammer until the collar of the plastic sleeve is flush with the surface of the fixture.

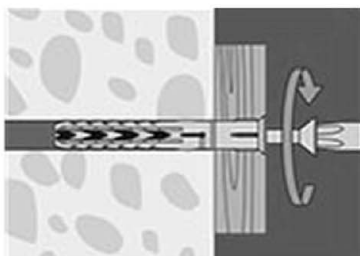

4. The screw is screwed-in until the head of the screw touches the sleeve. The anchor is correctly mounted, when the head of the screw fits tight on the surface and cannot be screwed-in any further.

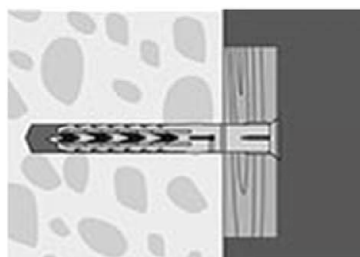

5. Correctly installed anchor in e.g. concrete.

frame fixing URD

Intended use
Installation instructions

Annex B 4

Appendix 8 / 22

Table C1.1: Characteristic bending resistance of the screw

Anchor type	URD 8		URD 10	
	galvanised steel	stainless steel	galvanised steel	stainless steel
Material	galvanised steel	stainless steel	galvanised steel	stainless steel
Characteristic bending resistance $M_{Rk,s}$ [Nm]	12,4	12,0	20,6	20,6
Partial safety factor γ_{Ms} ¹⁾	1,25	1,29	1,29	1,29

¹⁾ In absence of other national regulations.

Table C1.2: Characteristic resistance of the screw

Failure of expansion element (special screw)	URD 8		URD 10	
	galvanised steel	stainless steel	galvanised steel	stainless steel
Characteristic tension resistance $N_{Rk,s}$ [kN]	14,8	14,3	21,7	21,7
Partial safety factor γ_{Ms} ¹⁾	1,50	1,45	1,55	1,55
Characteristic shear resistance $V_{Rk,s}$ [kN]	7,4	7,1	10,8	10,8
Partial safety factor γ_{Ms} ¹⁾	1,25	1,29	1,29	1,29

¹⁾ In absence of other national regulations.

Table C1.3: Characteristic resistance for use in concrete (use category “a”)

Drill method in concrete: Hammerdrilling

Pull-out failure (plastic sleeve)	URD 8	URD 10
Embedment depth h_{nom} [mm]	50	50
Concrete \geq C12/15		
Characteristic resistance 30/50 °C $N_{Rk,p}$ [kN]	3,0	5,0
Characteristic resistance 50/80 °C $N_{Rk,p}$ [kN]	2,5 3,0 ²⁾	4,5
Concrete \geq C12/15 (e.g. weather resistant shells of external wall panels)		
Characteristic resistance 30/50 °C N_{Rk} [kN] $h \geq 40$ mm	⁷⁾	3,5
Characteristic resistance 50/80 °C N_{Rk} [kN] $h \geq 40$ mm	⁷⁾	3,0
Partial safety factor γ_{Mc} ¹⁾	1,8	

¹⁾ In absence of other national regulations.

²⁾ Value corresponds to concrete class \geq C16/20.

⁷⁾ No performance assessed

frame fixing URD

Performances

Characteristic resistance and characteristic bending resistance of the screw
Characteristic resistance for use in concrete

Annex C 1

Appendix 9 / 22

Table C2.1: Displacements¹⁾ under tension and shear loading in concrete and masonry

Anchor type	h _{nom} [mm]	F [kN]	Tension load ²⁾		Shear load ²⁾	
			δ _{NO} [mm]	δ _{N∞} [mm]	δ _{VO} [mm]	δ _{V∞} [mm]
URD 8	50	1,2	0,65	1,30	1,02	1,53
URD 10	50	2,0	1,29	2,58	1,15/3,05 ³⁾	1,74/4,58 ³⁾

1) Valid for all ranges of temperatures.

2) Intermediate values by linear interpolation.

3) Valid for diameter in the clearance hole ≤ 12,5 mm (see Table B2.1).

Table C2.2: Displacements¹⁾ under tension and shear loading in autoclaved aerated concrete

Anchor type	f _{ck} [N/mm ²]	h _{nom} [mm]	F [kN]	Tension load ²⁾		Shear load ²⁾	
				δ _{NO} [mm]	δ _{N∞} [mm]	δ _{VO} [mm]	δ _{V∞} [mm]
URD 10	≥ 2	50	0,32	0,03	0,06	0,21	0,31

1) Valid for all ranges of temperatures.

2) Intermediate values by linear interpolation.

Table C2.3: Values under fire exposure in concrete C20/25 to C50/60 in any load direction, no permanent centric tension load and without lever arm, fastening of façade systems

Anchor type	Fire resistance class	F _{Rk,fi}
URD 10	R 90	≤ 0,8 kN

frame fixing URD

Performances

Displacements under tension and shear loading in concrete, masonry and autoclaved aerated concrete, Characteristic values under fire exposure in concrete

Annex C 2

Appendix 10 / 22

Table C3.1: Characteristic resistance F_{Rk} in [kN] in solid masonry (use category “b”)

Base material [Supplier Title]	Geometry, DF or nom. size (L x W x H) [mm] and drilling method	Min. com- pressive strength f_b [N/mm ²] / bulk density ρ [kg/dm ³]	Characteristic resistance F_{Rk} [kN] 50/80°C	
			URD 8	URD 10
			$h_{nom} \geq 50$ mm	
Clay brick Mz as per EN 771-1:2011 <i>e.g. Schlagmann</i>	3 DF (240x175x113) by hammer drilling	20/1,8	3,0	2,0 4,0⁴⁾ 4,5⁶⁾
		10/1,8	2,0	1,5 3,0⁴⁾
Clay brick Mz as per EN 771-1:2011 <i>e.g. Schlagmann</i> <i>e.g. Ebersdobler</i>	NF (240x115x71) by hammer drilling	36/1,8	2,5	5,0
		20/1,8	2,5	3,0 3,5²⁾
		12/1,8	2,0	2,0
		10/1,8	2,0	2,0
Clay brick Mz as per EN 771-1:2011 <i>e.g. Wienerberger, DK</i>	DF (240x115x52) by hammer drilling	28/1,8	3,0	3,0
		20/1,8	2,0	2,0
		16/1,8	1,5	1,5
		12/1,8	1,5	1,2
		10/1,8	1,5	1,2
Partial safety factor		γ_{Mm} ¹⁾	2,5	

1) In absence of other national regulations.

2) Only valid for temperature range 30/50° C.

4) Only valid for edge distance $c \geq 200$ mm; intermediate values by linear interpolation.

6) Only valid for edge distance $c \geq 200$ mm for temperature range 30/50° C; intermediate values by linear interpolation.

frame fixing URD

Performances

Characteristic resistance for use in solid masonry

Annex C 3

Appendix 11 / 22

Table C4.1: Characteristic resistance F_{Rk} in [kN] in solid masonry (use category “b”)

Base material [Supplier Title]	Geometry, DF or nom. size (L x W x H) [mm] and drilling method	Min. compressive strength f_b [N/mm ²] / bulk density ρ [kg/dm ³]	Characteristic resistance F_{Rk} [kN] 50/80°C	
			URD 8	URD 10
			$h_{nom} \geq 50$ mm	
Calcium silicate solid brick KS as per EN 771-2:2011 <i>e.g. KS Wemding</i>	NF (240x115x71) by hammer drilling	36/2,0	7)	5,0
		20/2,0	7)	3,0 3,5²⁾
		20/1,8	2,5	2,5 4,0⁴⁾
		10/2,0	7)	2,0
		10/1,8	2,0	1,5
Calcium silicate solid brick KS as per EN 771-2:2011 <i>e.g. KS Wemding</i>	12 DF (495x175x240) by hammer drilling	28/2,0	3,0	5,0
		20/2,0	3,0	4,5
		10/2,0	2,5	3,0
Lightweight solid brick Vbl as per EN 771-3:2011 <i>e.g. KLB</i>	2 DF (240x115x113) by hammer drilling	4/1,4	7)	0,75
		2/1,4	7)	0,4
		2/1,2	0,9	0,75 0,9³⁾
Lightweight solid brick Vbl as per EN 771-3:2011 <i>e.g. KLB</i>	8 DF (490x240x115) by hammer drilling	12/1,8	2,5	7)
		10/1,8	2,5	7)
		8/1,8	2,5	7)
		8/1,6	7)	3,0
		6/1,8	2,0	7)
		6/1,6	7)	2,0
		4/1,8	1,2	7)
		2/1,2	7)	1,2
		2/1,0	1,2	7)
Partial safety factor		γ_{Mm} ¹⁾	2,5	

1) In absence of other national regulations.

2) Only valid for temperature range 30/50° C.

3) Only valid for edge distance $c \geq 150$ mm; intermediate values by linear interpolation.

4) Only valid for edge distance $c \geq 200$ mm; intermediate values by linear interpolation.

7) No performance assessed

frame fixing URD

Performances

Characteristic resistance for use in solid masonry

Annex C 4

Appendix 12 / 22

Table C5.1: Characteristic resistance F_{Rk} in [kN] in solid masonry (use category “b”)

Base material [Supplier Title]	Geometry, DF or nom. size (L x W x H) [mm] and drilling method	Min. compressive strength f_b [N/mm ²] / bulk density ρ [kg/dm ³]	Characteristic resistance F_{Rk} [kN] 50/80°C	
			URD 8	URD 10
			$h_{nom} \geq 50$ mm	
Lightweight solid brick Vbl as per EN 771-3:2011 <i>e.g. KLB</i>	8 DF (245x240x240) by hammer drilling	10/1,6	7)	2,5
		8/1,6	7)	2,5
		6/1,6	7)	2,5
		6/1,4	0,9	7)
		4/1,6	7)	0,9
		4/1,4	0,6 0,75²⁾	7)
		2/1,6	7)	0,5
Lightweight solid brick Vbl as per EN 771-3:2011 <i>e.g. Tarmac</i>	(440x100x215) by hammer drilling	6/1,4	7)	2,0 2,5⁴⁾
		4/1,4	7)	1,2 1,5⁴⁾
Solid brick normal concrete Vbn as per EN 771-3:2011 <i>e.g. Adolf Blatt</i>	(240x245x240) by hammer drilling	20/1,8	2,5	4,5
		16/1,8	2,5	3,5
		12/1,8	2,5	3,0
		10/1,8	1,5	3,0
		8/1,8	1,5	7)
		4/1,8	0,75	7)
Solid brick normal concrete Vbn as per EN 771-3:2011 <i>e.g. Tarmac GB</i>	(440x100x215) by hammer drilling	16/1,8	7)	4,0 4,5²⁾
		10/1,8	7)	2,5 3,0²⁾
Partial safety factor		γ_{Mm} ¹⁾	2,5	

1) In absence of other national regulations.

2) Only valid for temperature range 30/50° C.

4) Only valid for edge distance $c \geq 200$ mm; intermediate values by linear interpolation.

7) No performance assessed

frame fixing URD

Performances

Characteristic resistance for use in solid masonry

Annex C 5

Appendix 13 / 22

Table C6.1: Characteristic resistance F_{Rk} in [kN] in hollow or perforated masonry (use category “c”)

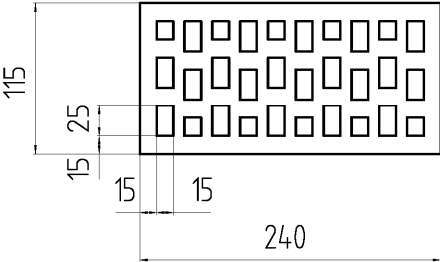
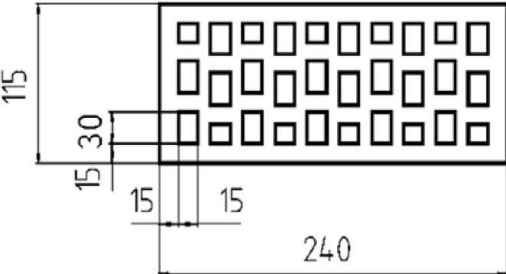
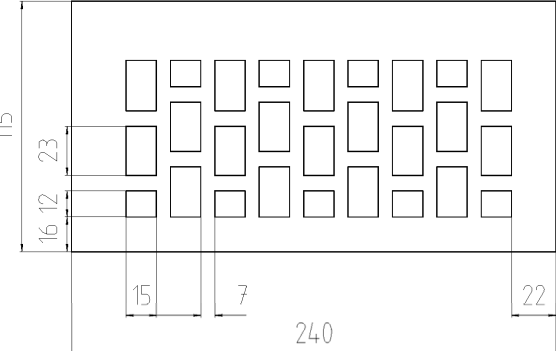
Base material [Supplier Title]	Geometry, DF or nom. size (L x W x H) [mm] and drilling method	Min. compressive strength f_b [N/mm ²] / bulk density ρ [kg/dm ³]	Characteristic resistance F_{Rk} [kN] 50/80°C	
			URD 8	URD 10
			$h_{nom} = 50 \text{ mm}$	
Perforated clay brick HLz Form B as per EN 771-1:2011 e.g. Wienerberger 	2 DF (240x115x113) by rotary drilling	20/1,2	1,2	2,5 3,0 ⁵⁾
		20/1,0	7)	2,0
		10/1,2	0,6	1,5 2,0 ²⁾
		10/1,0	7)	1,2
		8/1,2	0,5	7)
Perforated clay brick HLz as per EN 771-1:2011 e.g. Wienerberger 	2 DF (240x115x113) by rotary drilling	12/1,0	0,6	0,9
		10/1,0	7)	0,75
		8/1,0	0,4	0,6
Perforated clay brick VHLz as per EN 771-1:2011 e.g. Wienerberger 	2 DF (240x115x113) by rotary drilling	48/1,6	7)	2,5
		36/1,6	7)	2,0
		28/1,6	7)	1,5
		20/1,6	7)	0,9
		12/1,6	7)	0,6
Partial safety factor		γ_{Mm} ¹⁾	2,5	

1) In absence of other national regulations.

2) Only valid for temperature range 30/50° C.

5) Only valid for edge distance $c \geq 150 \text{ mm}$ at temperature range 30/50° C; intermediate values by linear interpolation.

7) No performance assessed

frame fixing URD

Performances

Characteristic resistance for use in hollow or perforated masonry

Annex C 6

Appendix 14 / 22

Table C7.1: Characteristic resistance F_{Rk} in [kN] in hollow or perforated masonry (use category "c")

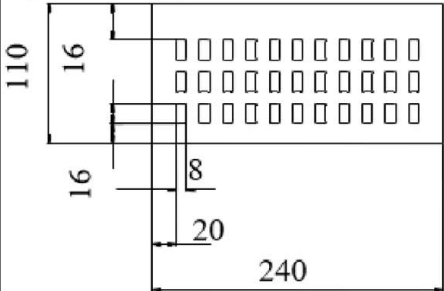
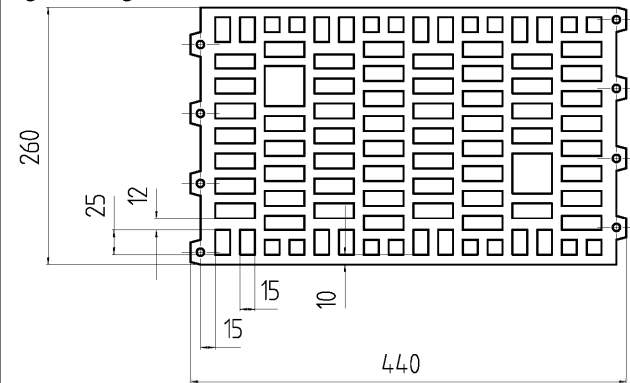
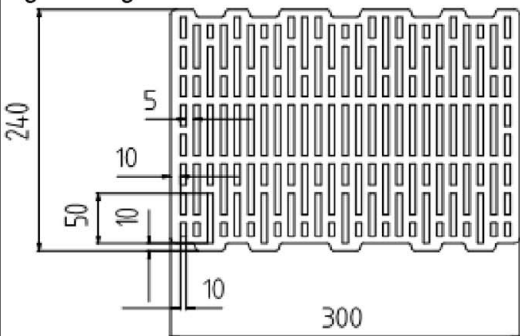
Base material [Supplier Title]	Geometry, DF or nom. size (L x W x H) [mm] and drilling method	Min. com- pressive strength f_b [N/mm ²] / bulk density ρ [kg/dm ³]	Characteristic resistance F_{Rk} [kN] 50/80°C		
			URD 8	URD 10	
			$h_{nom} = 50 \text{ mm}$		
Perforated clay brick HLz as per EN 771-1:2011 <i>e.g. Wienerberger, BS</i> 	DF (240x110x52) by hammer drilling	28/1,5	2,5	2,5	
		20/1,5	1,2 1,5²⁾	2,0	
		10/1,5	0,6 0,9²⁾	1,2	
Perforated clay brick HLz Form B as per EN 771-1:2011 <i>e.g. Schlagmann</i> 	10 DF (260x240x440) by rotary drilling	8/0,9	0,9	⁷⁾	
		6/0,9	0,6	⁷⁾	
		4/0,9	0,4	⁷⁾	
Perforated clay brick HLz as per EN 771-1:2011 <i>e.g. Schlagmann Poroton T14</i> 	10 DF (300x240x240) by rotary drilling	6/0,7	⁷⁾	0,3 0,4²⁾	
		Partial safety factor		$\gamma_{Mm}^{1)}$	2,5

- 1) In absence of other national regulations.
- 2) Only valid for temperature range 30/50° C.
- 7) No performance assessed

frame fixing URD

Performances

Characteristic resistance for use in hollow or perforated masonry

Annex C 7

Table C8.1: Characteristic resistance F_{Rk} in [kN] in hollow or perforated masonry (use category “c”)

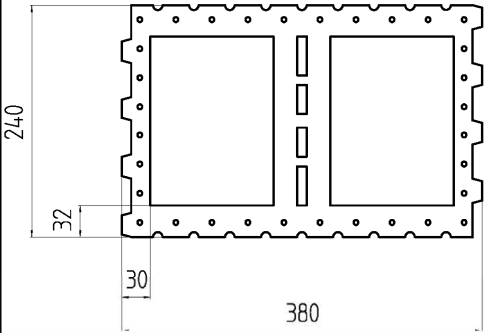
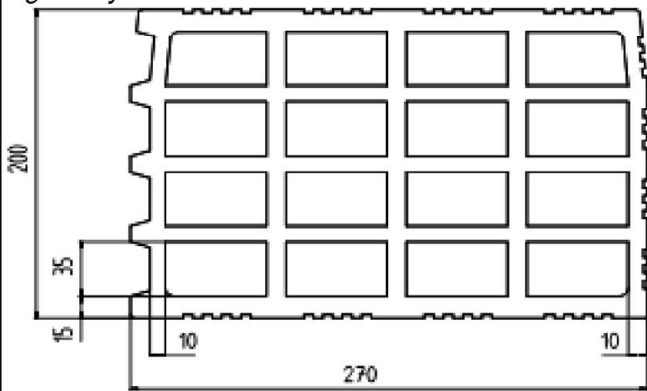
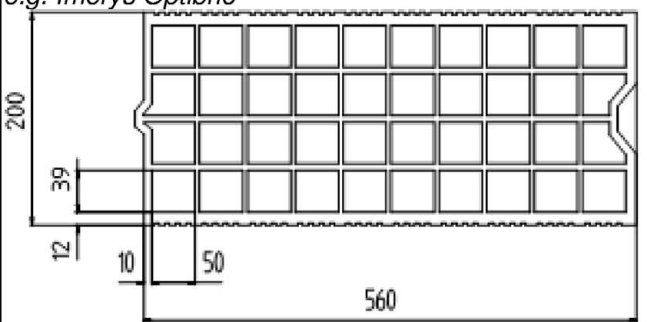
Base material [Supplier Title]	Geometry, DF or nom. size (L x W x H) [mm] and drilling method	Min. compressive strength f_b [N/mm ²] / bulk density ρ [kg/dm ³]	Characteristic resistance F_{Rk} [kN] 50/80°C	
			URD 8	URD 10
			$h_{nom} = 50 \text{ mm}$	
Perforated clay brick HLz Form B as per EN 771-1:2011 e.g. <i>Schlagmann Planfüllziegel</i> 	12 DF (380x240x240) by rotary drilling	6/0,7	1,2	2,0
		4/0,7	0,75	7)
		2/0,7	0,4	7)
Perforated clay brick HLz as per EN 771-1:2011 e.g. <i>Imerys Gelimatic</i> 	(500x200x270) by rotary drilling	6/0,6	7)	0,6 0,75⁶⁾
Perforated clay brick HLz as per EN 771-1:2011 e.g. <i>Imerys Optibric</i> 		(560x200x275) by rotary drilling	10/0,6	7)
Partial safety factor	γ_{Mm} ¹⁾		2,5	

1) In absence of other national regulations.

6) Only valid for edge distance $c \geq 200 \text{ mm}$ at temperature range 30/50° C; intermediate values by linear interpolation.

7) No performance assessed

frame fixing URD

Performances

Characteristic resistance for use in hollow or perforated masonry

Annex C 8

Appendix 16 / 22

Table C9.1: Characteristic resistance F_{Rk} in [kN] in hollow or perforated masonry (use category “c”)

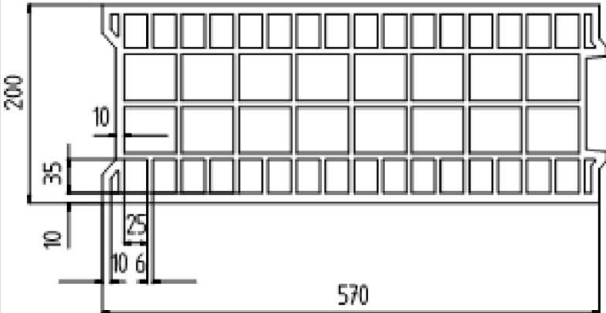
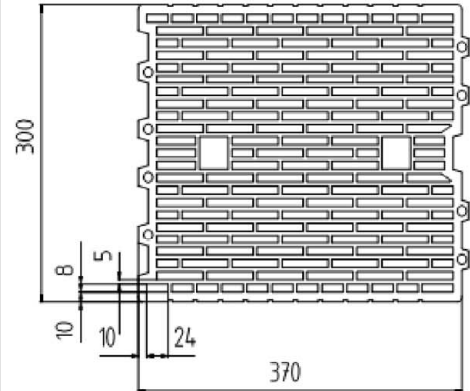
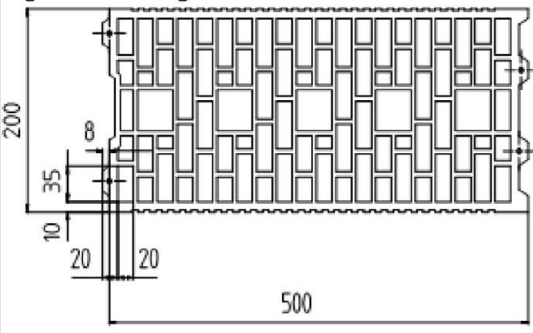
Base material [Supplier Title]	Geometry, DF or nom. size (L x W x H) [mm] and drilling method	Min. compressive strength f_b [N/mm ²] / bulk density ρ [kg/dm ³]	Characteristic resistance F_{Rk} [kN] 50/80°C	
			URD 8	URD 10
			$h_{nom} = 50$ mm	
Perforated clay brick HLz as per EN 771-1:2011 <i>e.g. Bouyer Leroux BGV</i> 	(570x200x315) by rotary drilling	6/0,6	7)	0,75 0,9³⁾ 1,2⁵⁾
Perforated clay brick HLz as per EN 771-1:2011 <i>e.g. Wienerberger Porotherm 30 R</i> 	(370x300x250) by rotary drilling	10/0,7	7)	0,5 0,6³⁾
Perforated clay brick HLz as per EN 771-1:2011 <i>e.g. Wienerberger Porotherm GF R20</i> 	(560x200x275) by rotary drilling	10/0,7	7)	0,6 0,75³⁾
Partial safety factor		$\gamma_{Mm}^{1)}$	2,5	

1) In absence of other national regulations.

3) Only valid for edge distance $c \geq 150$ mm; intermediate values by linear interpolation.

5) Only valid for edge distance $c \geq 150$ mm for temperature range 30/50° C; intermediate values by linear interpolation.

7) No performance assessed

frame fixing URD

Performances

Characteristic resistance for use in hollow or perforated masonry

Annex C 9

Appendix 17 / 22

Table C10.1: Characteristic resistance F_{Rk} in [kN] in hollow or perforated masonry (use category “c”)

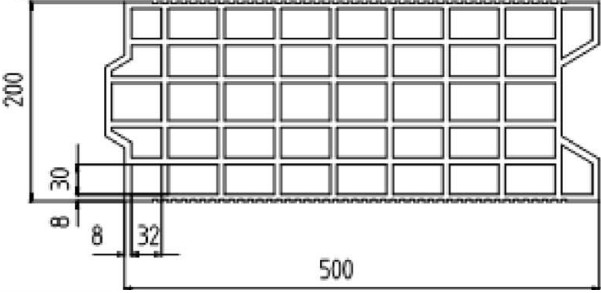
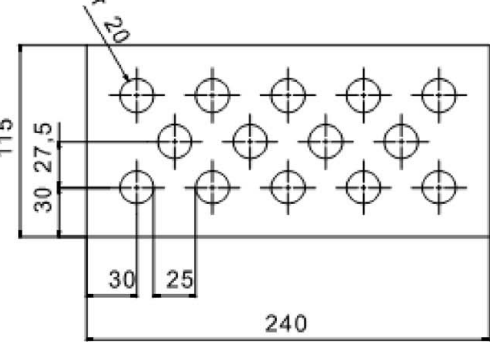
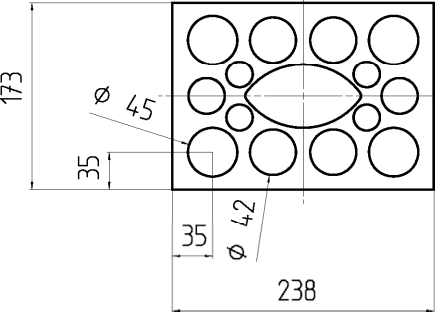
Base material [Supplier Title]	Geometry, DF or nom. size (L x W x H) [mm] and drilling method	Min. compressive strength f_b [N/mm ²] / bulk density ρ [kg/dm ³]	Characteristic resistance F_{Rk} [kN] 50/80°C	
			URD 8	URD 10
			$h_{nom} = 50 \text{ mm}$	
Perforated clay brick HLz as per EN 771-1:2011 <i>e.g. Terreal Calibric</i> 	(500x200x220) by rotary drilling	8/0,7	7)	0,6 0,75⁶⁾
Hollow calcium silicate brick KSL as per EN 771-2:2011 <i>e.g. KS Wemding</i> 	2 DF (240x115x113) by hammer drilling	12/1,4	2,0	2,0 2,5²⁾
		10/1,4	1,5	2,0
		8/1,4	1,2	1,5
		6/1,4	0,9	7)
Hollow calcium silicate brick KSL as per EN 771-2:2011 <i>e.g. KS Wemding</i> 	3 DF (240x175x113) by hammer drilling	20/1,4	1,2 1,5²⁾	7)
		16/1,4	0,9 1,2²⁾	7)
		12/1,4	0,75 0,9²⁾	7)
		10/1,4	0,6 0,75²⁾	7)
		8/1,4	0,5 0,6²⁾	7)
Partial safety factor		γ_{Mm} ¹⁾	2,5	

1) In absence of other national regulations.

2) Only valid for temperature range 30/50° C.

6) Only valid for edge distance $c \geq 200 \text{ mm}$ for temperature range 30/50° C; intermediate values by linear interpolation.

7) No performance assessed

frame fixing URD

Performances

Characteristic resistance for use in hollow or perforated masonry

Annex C 10

Appendix 18 / 22

Table C11.1: Characteristic resistance F_{Rk} in [kN] in hollow or perforated masonry (use category “c”)

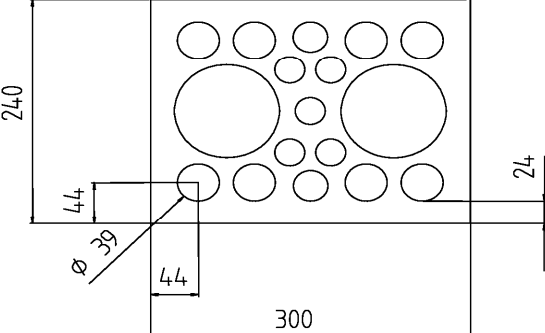
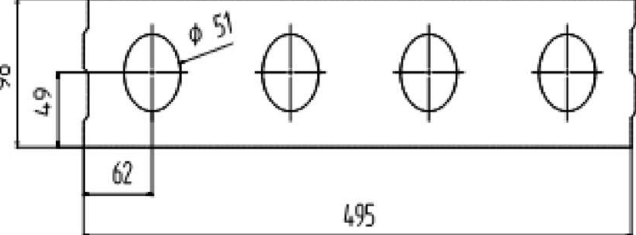
Base material [Supplier Title]	Geometry, DF or nom. size (L x W x H) [mm] and drilling method	Min. com- pressive strength f_b [N/mm ²] / bulk density ρ [kg/dm ³]	Characteristic resistance F_{Rk} [kN] 50/80°C	
			URD 8	URD 10
			$h_{nom} = 50 \text{ mm}$	
Hollow calcium silicate brick KSL as per EN 771-2:2011 e.g. <i>KS Wemding</i> 	5 DF (300x240x113) by hammer drilling	16/1,4	2,0	3,0 3,5⁵⁾
		12/1,4	1,5	7)
		10/1,4	1,2	1,5
		8/1,4	0,9	7)
		6/1,4	0,75 0,9²⁾	7)
Hollow calcium silicate brick KSL as per EN 771-2:2011 e.g. <i>KS Wemding, P10</i> 	(495x98x245) by hammer drilling	6/1,2	1,2 1,5²⁾	1,5 2,0³⁾ 2,5⁵⁾
		4/1,2	0,75 0,9²⁾	7)
		2/1,2	0,4 0,5²⁾	7)
Partial safety factor		γ_{Mm} ¹⁾	2,5	

1) In absence of other national regulations.

2) Only valid for temperature range 30/50° C.

3) Only valid for edge distance $c \geq 150 \text{ mm}$; intermediate values by linear interpolation.

5) Only valid for edge distance $c \geq 150 \text{ mm}$ for temperature range 30/50° C; intermediate values by linear interpolation.

7) No performance assessed

frame fixing URD

Performances

Characteristic resistance for use in hollow or perforated masonry

Annex C 11

Table C12.1: Characteristic resistance F_{Rk} in [kN] in hollow or perforated masonry (use category “c”)

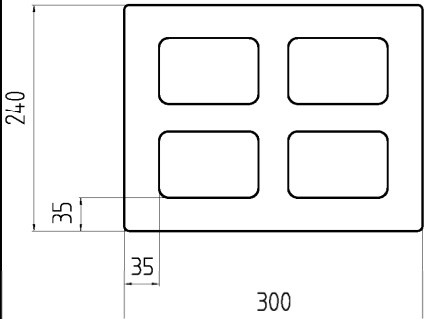
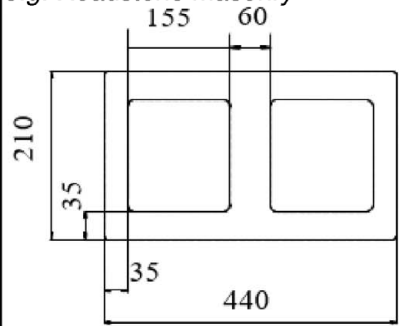
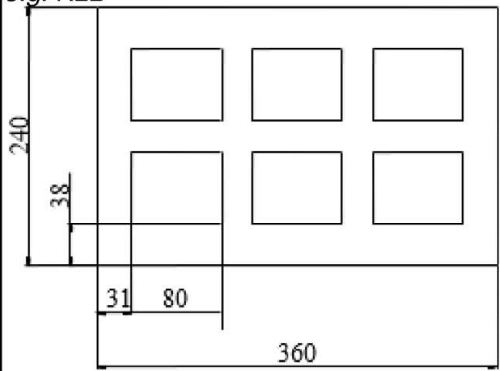
Base material [Supplier Title]	Geometry, DF or nom. size (L x W x H) [mm] and drilling method	Min. compressive strength f_b [N/mm ²] / bulk density ρ [kg/dm ³]	Characteristic resistance F_{Rk} [kN] 50/80°C	
			URD 8	URD 10
			$h_{nom} = 50 \text{ mm}$	
Hollow brick light-weight concrete Hbl as per EN 771-3:2011 e.g. <i>KLB</i> 	(300x240x240) by hammer drilling	2/1,2	7)	1,5
Hollow brick light-weight concrete Hbl as per EN 771-3:2011 e.g. <i>Roadstone masonry</i> 	(440x210x215) by hammer drilling	10/1,2	2,5	7)
		8/1,2	2,0	2,5
		6/1,2	1,5	2,0
Hollow brick light-weight concrete Hbl as per EN 771-3:2011 e.g. <i>KLB</i> 	(360x240x240) by hammer drilling	6/1,0	1,5	7)
Partial safety factor		$\gamma_{Mm}^{1)}$	2,5	

1) In absence of other national regulations.
 7) No performance assessed

frame fixing URD

Performances

Characteristic resistance for use in hollow or perforated masonry

Annex C 12

Table C13.1: Characteristic resistance F_{Rk} in [kN] in hollow or perforated masonry (use category “c”)

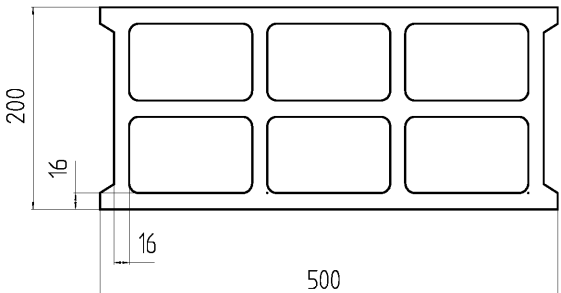
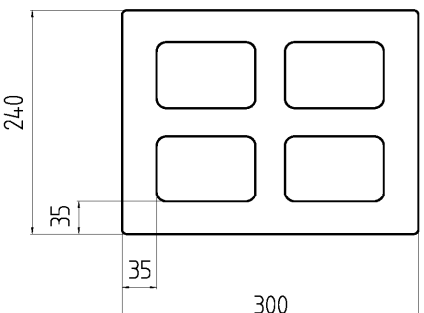
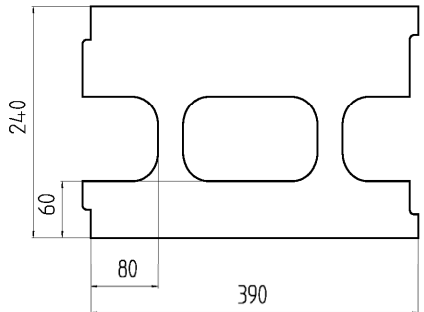
Base material [Supplier Title]	Geometry, DF or nom. size (L x W x H) [mm] and drilling method	Min. com- pressive strength f_b [N/mm ²] / bulk density ρ [kg/dm ³]	Characteristic resistance F_{Rk} [kN] 50/80°C	
			URD 8	URD 8
			$h_{nom} = 50$ mm	
Hollow brick light-weight concrete Hbl as per EN 771-3:2011 e.g. <i>Sepa Parpaing</i> 	(500x200x200) by rotary drilling	4/0,9	0,3 0,4²⁾	0,9 1,2⁴⁾ 1,5⁶⁾
Hollow brick normal concrete Hbn as per EN 771-3:2011 e.g. <i>Adolf Blatt</i> 	(300x240x240) by hammer drilling	6/1,6	⁷⁾	2,5
		4/1,6	⁷⁾	1,5
		2/1,6	⁷⁾	0,75
Heat insulation brick WDB e.g. <i>Gisoton</i> 	(390x240x240) by hammer drilling	2/0,7	⁷⁾	1,5
Partial safety factor		γ_{Mm} ¹⁾	2,5	

1) In absence of other national regulations.

2) Only valid for temperature range 30/50° C.

4) Only valid for edge distance $c \geq 200$ mm; intermediate values by linear interpolation.

6) Only valid for edge distance $c \geq 200$ mm for temperature range 30/50° C; intermediate values by linear interpolation.

7) No performance assessed

frame fixing URD

Performances

Characteristic resistance for use in hollow or perforated masonry

Annex C 13

Appendix 21 / 22

Table C14.1: Characteristic resistance F_{Rk} in [kN] in autoclaved aerated concrete (use category "d")

Base material [Supplier Title]	Geometry, DF or nom. size (L x W x H) [mm] and drilling method	Min. compressive strength f_{ck} [N/mm ²]	Characteristic resistance F_{Rk} [kN] 50/80°C	
			URD 8	URD 10
			$h_{nom} \geq 50$ mm	
Autoclaved aerated concrete as per EN 771-4:2011	e.g. (500x120x300)	≥ 6	7)	0,75 0,9⁵⁾
	e.g. (500x250x300)	≥ 4	7)	0,75 0,9²⁾
	by hammer drilling	≥ 3	7)	0,4³⁾ 0,5²⁾³⁾
		≥ 2	7)	0,4³⁾ 0,5²⁾³⁾
Partial safety factor		$\gamma_{MAAC}^{1)}$	2,0	

1) In absence of other national regulations.

2) Only valid for temperature range 30/50° C.

3) For the fixing in autoclaved aerated concrete with a nominal compressive strength $f_{ck} < 4$ N/mm² the hole is made by using the accompanying AAC hole punch according Table C14.2.

5) Nur für Randabstand $c \geq 120$ mm.

7) No performance assessed

Table C14.2: Assignment AAC hole punch type – anchor type (length) only for autoclaved aerated concrete with $f_{ck} < 4$ N/mm² URD 10

Hole punch only for URD 10 $h_{nom} = 50$ mm, $f_{ck} < 4$ N/mm ²					Anchor type (length)	
Type	a_1	a_2	b	l		
GBS 10 x 80	9	10	80	85	URD 10 x 52 URD 10 x 60 URD 10 x 80	
GBS 10 x 100				105	URD 10 x 100	
GBS 10 x 135			140	URD 10 x 120		
GBS 10 x 160			90	165	URD 10 x 140 URD 10 x 160	
GBS 10 x 185				190	URD 10 x 180	
GBS 10 x 230				235	URD 10 x 200 URD 10 x 230	

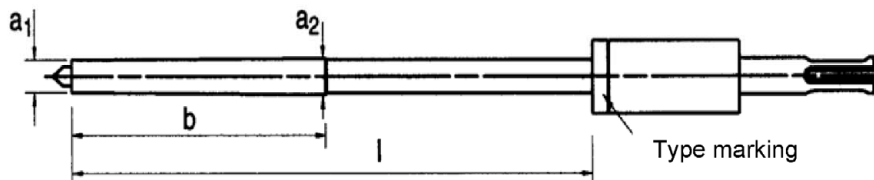

frame fixing URD

Performances

Characteristic resistance for use in autoclaved aerated concrete / Assignment hole punch

Annex C 14

Appendix 22 / 22