



DECLARATION OF PERFORMANCE

DoP 0204

for Upat injection system UPM 33 (Bonded fastener for use in concrete)

EN

1. Unique identification code of the product-type: DoP 0204
2. Intended use/es: Post-installed fastening in cracked or uncracked concrete, see appendix, especially annexes B1 - B8.
3. Manufacturer: Upat Vertriebs GmbH, Bebelstraße 11, 79108 Freiburg im Breisgau, Germany
4. Authorised representative: -
5. System/s of AVCP: 1
6. European Assessment Document: EAD 330499-01-0601, Edition 04/2020
European Technical Assessment: ETA-10/0171; 2021-04-28
Technical Assessment Body: DIBt- Deutsches Institut für Bautechnik
Notified body/ies: 2873 TU Darmstadt
7. Declared performance/s:
Mechanical resistance and stability (BWR 1)
Characteristic resistance to tension load (static and quasi-static loading):
Resistance to steel failure: Annexes C1, C2
Resistance to combined pull- out and concrete cone failure: Annexes C3 - C5
Resistance to concrete cone failure: Annex C3
Edge distance to prevent splitting under load: Annex C3
Robustness: Annexes C3 - C5
Maximum installation torque: Annexes B3, B4
Minimum edge distance and spacing: Annexes B3, B4
Characteristic resistance to shear load (static and quasi-static loading):
Resistance to steel failure: Annexes C1 - C2
Resistance to pry-out failure: Annex C3
Resistance to concrete edge failure: Annex C3
Characteristic resistance and displacements for seismic performance categories C1 and C2:
Resistance to tension load, displacements, category C1: NPD
Resistance to tension load, displacements, category C2: NPD
Resistance to shear load, displacements, category C1: NPD
Resistance to shear load, displacements, category C2: NPD
Factor annular gap: NPD
Displacements under short-term and long-term loading:
Displacements under short-term and long-term loading: Annex C6
Hygiene, health and the environment (BWR 3)
Content, emission and/or release of dangerous substances: NPD
8. Appropriate Technical Documentation and/or Specific Technical Documentation: -

$E_s = 210\,000\text{ MPa}$
 $\psi_{sus}^0 = \text{NPD}$

The performance of the product identified above is in conformity with the set of declared performance/s. This declaration of performance is issued, in accordance with Regulation (EU) No 305/2011, under the sole responsibility of the manufacturer identified above.

Signed for and on behalf of the manufacturer by:

Dr.-Ing. Oliver Geibig, Managing Director Business Units & Engineering
Tumlingen, 2021-05-12

Jürgen Grün, Managing Director Chemistry & Quality

This DoP has been prepared in different languages. In case there is a dispute on the interpretation the English version shall always prevail.

The Appendix includes voluntary and complementary information in English language exceeding the (language-neutrally specified) legal requirements.

Specific Part

1 Technical description of the product

The "Injection system UPM 33" is a bonded fastener consisting of a cartridge with injection mortar UPM 33, UPM 33 Relax or UPM 33 Express and a steel element according to Annex A4.

The steel element is placed into a drilled hole filled with injection mortar and is anchored via the bond between metal part, injection mortar and concrete.

The product description is given in Annex A.

2 Specification of the intended use in accordance with the applicable European Assessment Document

The performances given in Section 3 are only valid if the anchor is used in compliance with the specifications and conditions given in Annex B.

The verifications and assessment methods on which this European Technical Assessment is based lead to the assumption of a working life of the anchor of at least 50 years. The indications given on the working life cannot be interpreted as a guarantee given by the producer, but are to be regarded only as a means for choosing the right products in relation to the expected economically reasonable working life of the works.

3 Performance of the product and references to the methods used for its assessment

3.1 Mechanical resistance and stability (BWR 1)

Essential characteristic	Performance
Characteristic resistance to tension load (static and quasi-static loading)	See Annex B 3 and B 4, C 1 to C 5
Characteristic resistance to shear load (static and quasi-static loading)	See Annex C 1 to C 3
Displacements under short-term and long-term loading	See Annex C 6
Characteristic resistance and displacements for seismic performance categories C1 and C2	No performance assessed

3.2 Hygiene, health and the environment (BWR 3)

Essential characteristic	Performance
Content, emission and/or release of dangerous substances	No performance assessed

4 Assessment and verification of constancy of performance (AVCP) system applied, with reference to its legal base

In accordance with the European Assessment Document EAD 330499-01-0601 the applicable European legal act is: [96/582/EC].

The system to be applied is: 1

Installation conditions part 1

Upat anchor rod

Pre-positioned installation

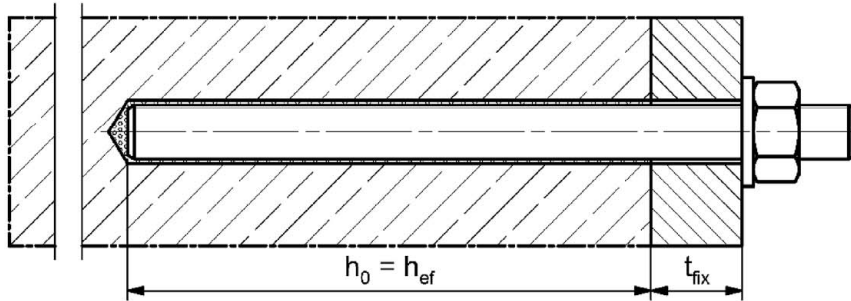

Push through installation (annular gap filled with mortar)

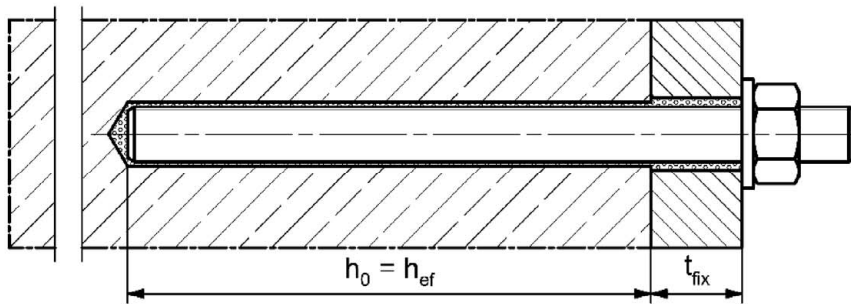

Pre-positioned or push through installation with subsequently injected filling disc (annular gap filled with mortar)

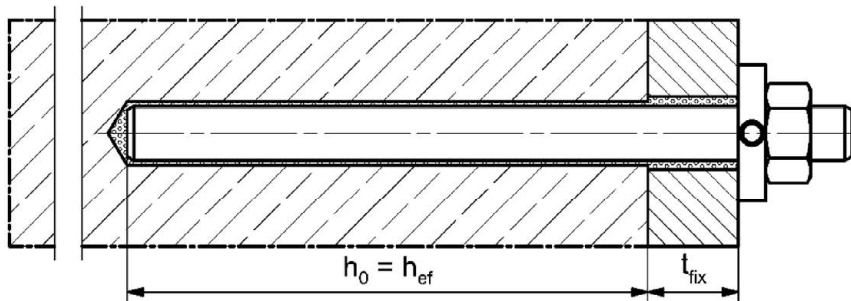

Figures not to scale

h_0 = drill hole depth

h_{ef} = effective embedment depth

t_{fix} = thickness of fixture

Injection system UPM 33

Product description
Installation conditions part 1

Annex A 1

Appendix 3 / 21

Installation conditions part 2

Upat internal threaded anchor IST

Pre-positioned installation

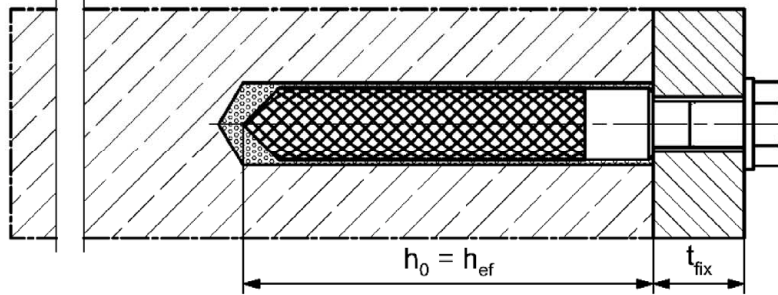

Pre-positioned installation with subsequently injected filling disc (annular gap filled with mortar)

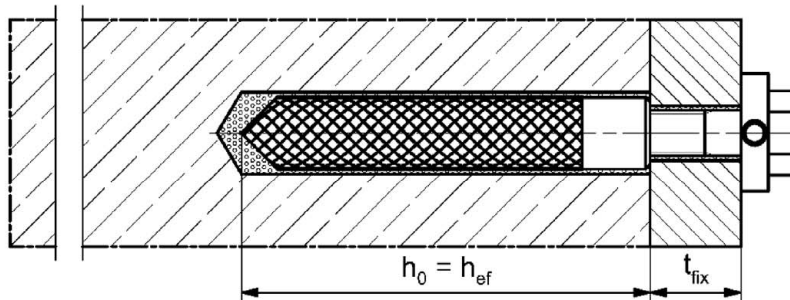

Figures not to scale

h_0 = drill hole depth

h_{ef} = effective embedment depth

t_{fix} = thickness of fixture

Injection system UPM 33

Product description
Installation conditions part 2

Annex A 2

Appendix 4 / 21

Overview system components part 1

Injection cartridge (shuttle cartridge) with sealing cap; Sizes: 350 ml, 360 ml, 390 ml, 550 ml, 1100 ml, 1500 ml

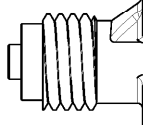
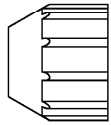

Imprint: UPM 33 or UPM 33 Relax or UPM 33 Express, processing notes, shelf-life, piston travel scale (optional), curing times and processing times (depending on temperature), hazard code, size, volume



Injection cartridge (coaxial cartridge) with sealing cap; Sizes: 100 ml, 150 ml, 300 ml, 380 ml, 400 ml, 410 ml

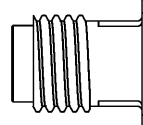
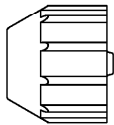

Imprint: UPM 33 or UPM 33 Relax or UPM 33 Express, processing notes, shelf-life, piston travel scale (optional), curing times and processing times (depending on temperature), hazard code, size, volume



Static mixer Upat MR Plus

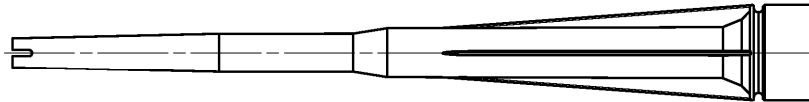

Injection adapter and Extension tube for static mixer

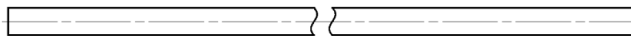
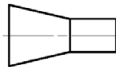

Cleaning brush UP BS



Blow-out pump UPM or ABP



Figures not to scale

Injection system UPM 33

Product description

Overview system components part 1;
cartridges / static mixer / accessories

Annex A 3

Appendix 5 / 21

Overview system components part 2

Upat anchor rod

Size: M6, M8, M10, M12, M16, M20, M24, M27, M30



Upat internal threaded anchor IST

Size: M8, M10, M12, M16, M20



Screw / threaded rod / washer / hexagon nut

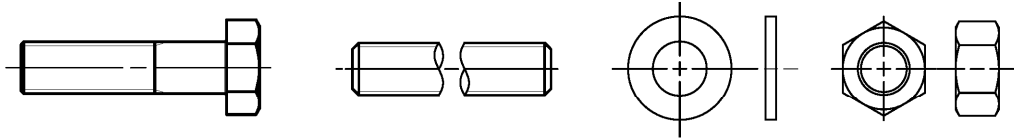

filling disc with injection adapter

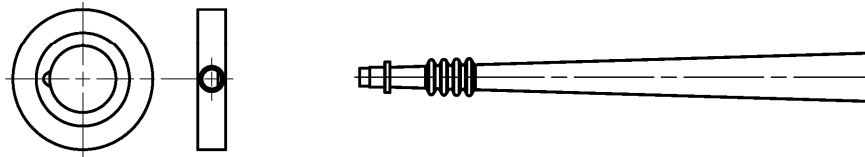

Figures not to scale

Injection system UPM 33

Product description

Overview system components part 2;
steel components

Annex A 4

Appendix 6 / 21

Table A5.1: Materials

Part	Designation	Material		
1	Injection cartridge	Mortar, hardener, filler		
	Steel grade	Steel	Stainless steel R	High corrosion resistant steel HCR
		zinc plated	acc. to EN 10088-1:2014 Corrosion resistance class CRC III acc. to EN 1993-1-4:2015	acc. to EN 10088-1:2014 Corrosion resistance class CRC V acc. to EN 1993-1-4:2015
2	Anchor rod	Property class 4.8, 5.8 or 8.8; EN ISO 898-1:2013 zinc plated $\geq 5 \mu\text{m}$, ISO 4042:2018/Zn5/An(A2K) or hot dip galvanised $\geq 40 \mu\text{m}$ EN ISO 10684:2004 $f_{uk} \leq 1000 \text{ N/mm}^2$ $A_5 > 8\%$ fracture elongation	Property class 50, 70 or 80 EN ISO 3506-1:2009 1.4401; 1.4404; 1.4578; 1.4571; 1.4439; 1.4362; 1.4062, 1.4662, 1.4462; EN 10088-1:2014 $f_{uk} \leq 1000 \text{ N/mm}^2$ $A_5 > 8\%$ fracture elongation	Property class 50 or 80 EN ISO 3506-1:2009 or property class 70 with $f_{yk} = 560 \text{ N/mm}^2$ 1.4565; 1.4529; EN 10088-1:2014 $f_{uk} \leq 1000 \text{ N/mm}^2$ $A_5 > 8\%$ fracture elongation
3	Washer ISO 7089:2000	zinc plated $\geq 5 \mu\text{m}$, ISO 4042:2018/Zn5/An(A2K) or hotdip galvanised $\geq 40 \mu\text{m}$ EN ISO 10684:2004	1.4401; 1.4404; 1.4578; 1.4571; 1.4439; 1.4362; EN 10088-1:2014	1.4565; 1.4529; EN 10088-1:2014
4	Hexagon nut	Property class 4, 5 or 8; EN ISO 898-2:2012 zinc plated $\geq 5 \mu\text{m}$, ISO 4042:2018/Zn5/An(A2K) or hot dip galvanised $\geq 40 \mu\text{m}$ EN ISO 10684:2004	Property class 50, 70 or 80 EN ISO 3506-1:2009 1.4401; 1.4404; 1.4578; 1.4571; 1.4439; 1.4362; EN 10088-1:2014	Property class 50, 70 or 80 EN ISO 3506-1:2009 1.4565; 1.4529 EN 10088-1:2014
5	Upat internal threaded anchor IST	Property class 5.8 ISO 898-1:2013 zinc plated $\geq 5 \mu\text{m}$, ISO 4042:2018/Zn5/An(A2K)	Property class 70 EN ISO 3506-1:2009 1.4401; 1.4404; 1.4578; 1.4571; 1.4439; 1.4362; EN 10088-1:2014	Property class 70 EN ISO 3506-1:2009 1.4565; 1.4529; EN 10088-1:2014
6	Commercial standard screw or threaded rod for Upat internal threaded anchor IST	Property class 5.8 or 8.8; EN ISO 898-1:2013 zinc plated $\geq 5 \mu\text{m}$, ISO 4042:2018/Zn5/An(A2K) $A_5 > 8\%$ fracture elongation	Property class 70 EN ISO 3506-1:2009 1.4401; 1.4404; 1.4578; 1.4571; 1.4439; 1.4362; EN 10088-1:2014 $A_5 > 8\%$ fracture elongation	Property class 70 EN ISO 3506-1:2009 1.4565; 1.4529; EN 10088-1:2014 $A_5 > 8\%$ fracture elongation
7	filling disc similar to DIN 6319-G	zinc plated $\geq 5 \mu\text{m}$, ISO 4042:2018/Zn5/An(A2K) or hot dip galvanised $\geq 40 \mu\text{m}$ EN ISO 10684:2004	1.4401; 1.4404; 1.4578; 1.4571; 1.4439; 1.4362; EN 10088-1:2014	1.4565; 1.4529; EN 10088-1:2014

Injection system UPM 33





Product description
Materials

Annex A 5

Appendix 7 / 21

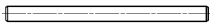
Specifications of intended use (part 1)

Table B1.1: Overview use and performance categories

Anchorages subject to		UPM 33 with ...			
		Anchor rod 		Upat internal threaded anchor IST 	
Hammer drilling with standard drill bit 		all sizes			
Hammer drilling with hollow drill bit (fischer FHD, Heller "Duster Expert"; Bosch „Speed Clean“; Hilti "TE-CD, TE-YD", DreBo „D-Plus“, DreBo „D-Max“) 		Nominal drill bit diameter (d_0) 12 mm to 35 mm			
Static and quasi static load, in	uncracked concrete	all sizes	Tables: C1.1 C3.1 C4.1 C6.1	all sizes	Tables: C2.1 C3.1 C5.1 C6.2
	cracked concrete	M10 bis M20		_2)	
Use category	I1 dry or wet concrete	all sizes			
	I2 water filled hole ¹⁾	M 12 to M 30	M 8 bis M 20		
Installation direction		D3 (downward and horizontal and upwards (e.g. overhead) installation)			
Installation temperature		$T_{i,min} = -10\text{ °C}$ to $T_{i,max} = +40\text{ °C}$ for the standard variation of temperature after installation			
In-service temperature	Temperature range I	-40 °C to +80 °C	(max. short term temperature +80 °C; max. long term temperature +50 °C)		
	Temperature range II	-40 °C to +120 °C	(max. short term temperature +120 °C; max. long term temperature +72 °C)		

¹⁾ Only with coaxial cartridges: 380ml, 400 ml, 410 ml

²⁾ No performance assessed

Injection system UPM 33

Intended use
Specifications (part 1)

Annex B 1

Appendix 8 / 21

Specifications of intended use (part 2)

Base materials:

- Compacted reinforced or unreinforced normal weight concrete without fibres of strength classes C20/25 to C50/60 according to EN 206:2013+A1:2016

Use conditions (Environmental conditions):

- Structures subject to dry internal conditions (zinc coated steel, stainless steel or high corrosion resistant steel).
- For all other conditions according to EN1993-1-4:2015 corresponding to corrosion resistance classes to Annex A 5 table A5.1.

Design:

- Anchorages have to be designed by a responsible engineer with experience of concrete anchor design.
- Verifiable calculation notes and drawings are to be prepared taking account of the loads to be anchored. The position of the anchor is indicated on the design drawings (e. g. position of the anchor relative to reinforcement or to supports, etc.).
- Anchorages are designed in accordance with: EN 1992-4:2018 and EOTA Technical Report TR 055, Edition February 2018.

Installation:

- Anchor installation is to be carried out by appropriately qualified personnel and under the supervision of the person responsible for technical matters of the site
- In case of aborted hole: The hole shall be filled with mortar
- Anchorage depth should be marked and adhered to on installation
- Overhead installation is allowed

Injection system UPM 33

Intended use
Specifications (part 2)

Annex B 2

Appendix 9 / 21

Table B3.1: Installation parameters for **anchor rods**

Anchor rods		Thread	M6	M8	M10	M12	M16	M20	M24	M27	M30	
Width across flats	SW	[mm]	10	13	17	19	24	30	36	41	46	
Nominal drill hole diameter	d_0		8	10	12	14	18	24	28	30	35	
Drill hole depth	h_0		$h_0 = h_{ef}$									
Effective embedment depth	$h_{ef, min}$		50	60	60	70	80	90	96	108	120	
	$h_{ef, max}$		72	160	200	240	320	400	480	540	600	
Minimum spacing and minimum edge distance	$s_{min} = c_{min}$		40	40	45	55	65	85	105	125	140	
Diameter of the clearance hole of the fixture	pre-positioned installation		d_f	7	9	12	14	18	22	26	30	33
	push through installation		d_f	9	12	14	16	20	26	30	33	40
Minimum thickness of concrete member	h_{min}		$h_{ef} + 30 (\geq 100)$					$h_{ef} + 2d_0$				
Maximum installation torque	$\max T_{inst}$		[Nm]	5	10	20	40	60	120	150	200	300

Upat anchor rod

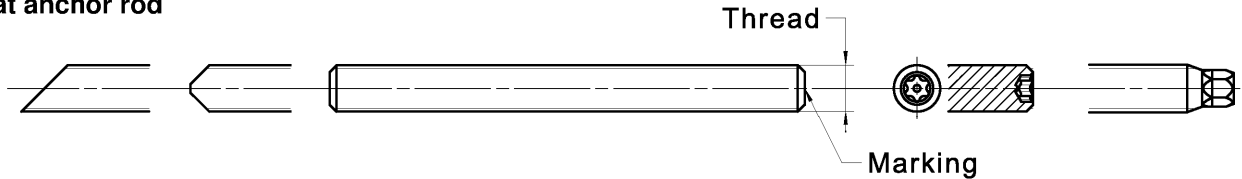

Marking (on random place) Upat anchor rod:

Steel zinc plated PC ¹⁾ 8.8	• or +	Steel hot-dip PC ¹⁾ 8.8	•
High corrosion resistant steel HCR PC ¹⁾ 50	•	High corrosion resistant steel HCR PC ¹⁾ 70	-
High corrosion resistant steel HCR PC ¹⁾ 80	(Stainless steel R property class 50	~
Stainless steel R property class 80	*		
Alternatively: Colour coding according to DIN 976-1:2016		1) PC = property class	

Installation conditions:

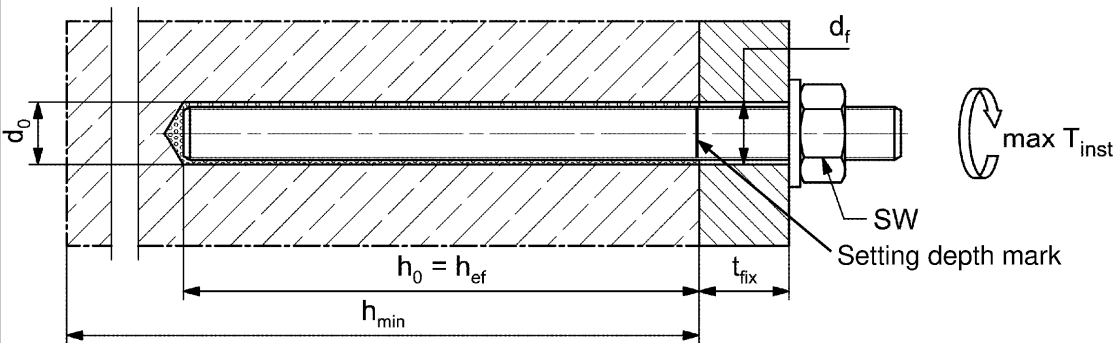

Commercial standard threaded rods, washers and hexagon nuts may also be used if the following requirements are fulfilled

- Materials, dimensions and mechanical properties according to Annex A 5, Table A5.1
- Inspection certificate 3.1 according to EN 10204:2004, the documents have to be stored
- Setting depth is marked

Figures not to scale

Injection system UPM 33

Intended use
Installation parameters anchor rods

Annex B 3

Appendix 10 / 21

Table B4.1: Installation parameters for **Upat internal threaded anchors IST**

Internal threaded anchors IST		Thread	M8	M10	M12	M16	M20
Diameter of anchor	$d_{nom} = d_H$	[mm]	12	16	18	22	28
Nominal drill hole diameter	d_0		14	18	20	24	32
Drill hole depth	h_0		$h_0 = h_{ef} = L_H$				
Effective embedment depth ($h_{ef} = L_H$)	h_{ef}		90	90	125	160	200
Minimum spacing and minimum edge distance	$s_{min} = c_{min}$		55	65	75	95	125
Diameter of clearance hole in the fixture	d_f		9	12	14	18	22
Minimum thickness of concrete member	h_{min}		120	125	165	205	260
Maximum screw-in depth	$l_{E,max}$		18	23	26	35	45
Minimum screw-in depth	$l_{E,min}$		8	10	12	16	20
Maximum installation torque	$\max T_{inst}$	[Nm]	10	20	40	80	120

Upat internal threaded anchor IST

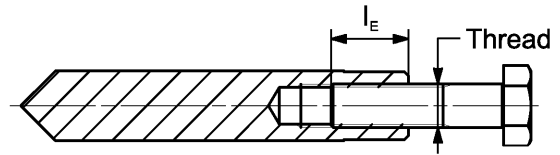
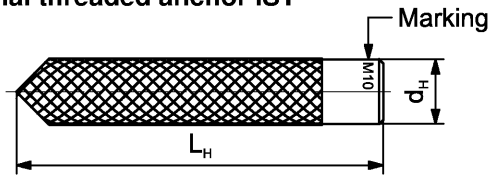

Marking: Anchor size e. g.: **M10**
 Stainless steel → additional **R**; e.g.: **M10 R**
 High corrosion resistant steel → additional **HCR**; e.g.: **M10 HCR**

Retaining bolt or threaded rods (including nut and washer) must comply with the appropriate material and strength class of Annex A 5, Table A5.1

Installation conditions:

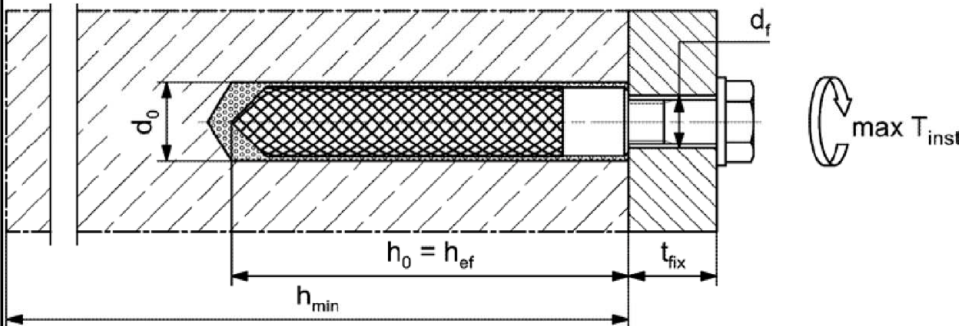

Figures not to scale

Injection system UPM 33

Intended use
 Installation parameters Upat internal threaded anchors IST

Annex B 4
 Appendix 11 / 21

Table B5.1: Parameters of the **cleaning brush UP BS** (steel brush with steel bristles)

The size of the cleaning brush refers to the drill hole diameter

Nominal drill hole diameter	d_0	[mm]	8	10	12	14	16	18	20	24	25	28	30	35
Steel brush diameter BS	d_b		9	11	14	16	20		25	26	27	30	40	

**Table B5.2** **Maximum processing time** of the mortar and **minimum curing time** (During the curing time of the mortar the concrete temperature may not fall below the listed minimum temperature)

Temperature at anchoring base [°C]	Maximum processing time t_{work}			Minimum curing time ¹⁾ t_{cure}		
	UPM 33 Express	UPM 33	UPM 33 Relax	UPM 33 Express	UPM 33	UPM 33 Relax
-10 to -5 ²⁾	-	-	-	12 h	-	-
> -5 to 0 ²⁾	5 min	-	-	3 h	24 h	-
> 0 to 5 ²⁾	5 min	13 min	-	3 h	3 h	6 h
> 5 to 10	3 min	9 min	20 min	50 min	90 min	3 h
> 10 to 20	1 min	5 min	10 min	30 min	60 min	2 h
> 20 to 30	-	4 min	6 min	-	45 min	60 min
> 30 to 40	-	2 min	4 min	-	35 min	30 min

¹⁾ In wet concrete or water filled holes the curing times must be doubled²⁾ Minimal cartridge temperature +5°C

Injection system UPM 33

Intended useCleaning brush (steel brush)
Processing time and curing time**Annex B 5**

Appendix 12 / 21

Installation instructions part 1

Drilling and cleaning the hole (hammer drilling with standard drill bit)

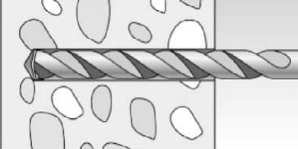
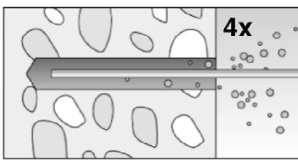
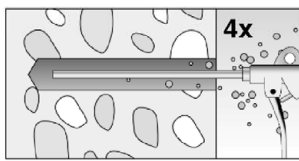
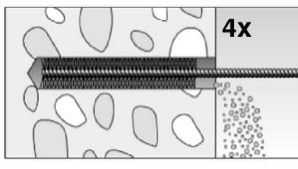
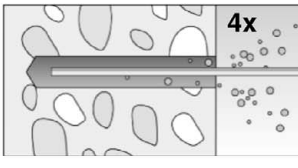
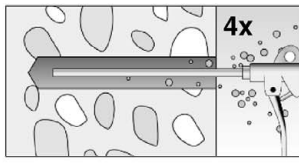
1		<p>Drill the hole. Nominal drill hole diameter d_0 and drill hole depth h_0 see tables B3.1, B4.1</p>
2		 <p>Clean the drill hole: For $h_{ef} \leq 12d$ and $d_0 < 18$ mm blow out the hole four times by hand</p> <p>For $h_{ef} > 12d$ and / or $d_0 \geq 18$ mm blow out the hole four times with oil-free compressed air ($p \geq 6$ bar)</p>
3		<p>Brush the drill hole four times. For deep holes use an extension. Corresponding brushes see table B5.1</p>
4		 <p>Clean the drill hole: For $h_{ef} \leq 12d$ and $d_0 < 18$ mm blow out the hole four times by hand</p> <p>For $h_{ef} > 12d$ and / or $d_0 \geq 18$ mm blow out the hole four times with oil-free compressed air ($p \geq 6$ bar)</p>

Go to step 5

Drilling and cleaning the hole (hammer drilling with hollow drill bit)

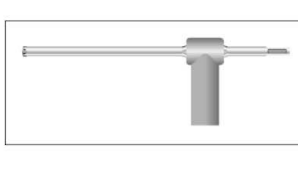
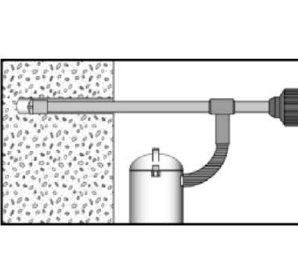
1		<p>Check a suitable hollow drill (see table B1.1) for correct operation of the dust extraction</p>
2		<p>Use a suitable dust extraction system, e. g. fischer FVC 35 M or a comparable dust extraction system with equivalent performance data</p> <p>Drill the hole with hollow drill bit. The dust extraction system has to extract the drill dust nonstop during the drilling process and must be adjusted to maximum power. Nominal drill hole diameter d_0 and drill hole depth h_0 see tables B3.1, B4.1</p>

Go to step 5

Injection system UPM 33

Intended use
Installation instructions part 1

Annex B 6

Appendix 13 / 21

Installation instructions part 2

Preparing the cartridge

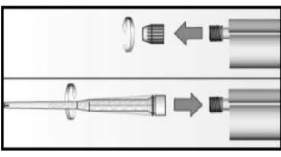
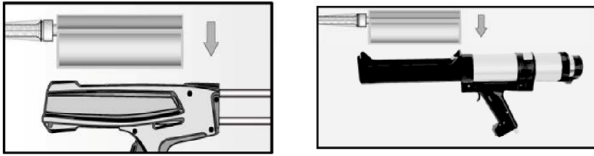
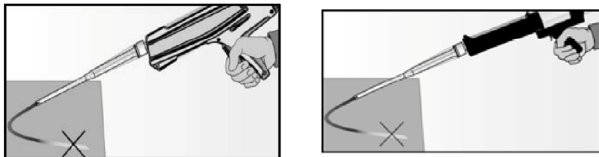
5		Remove the sealing cap Screw on the static mixer (the spiral in the static mixer must be clearly visible)
6		Place the cartridge into the dispenser
7		Extrude approximately 10 cm of material out until the resin is evenly grey in colour. Do not use mortar that is not uniformly grey

Go to step 8

Injection of the mortar

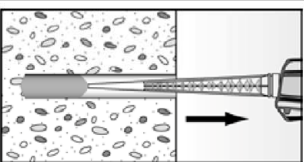
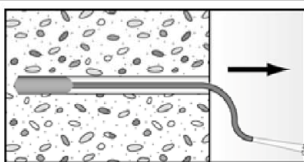
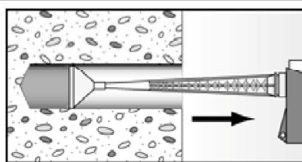
8			
Fill approximately 2/3 of the drill hole with mortar. Always begin from the bottom of the hole and avoid bubbles	For drill hole depth ≥ 150 mm use an extension tube	For overhead installation, deep holes ($h_0 > 250$ mm) or drill hole diameter ($d_0 \geq 40$ mm) use an injection adapter	

Go to step 9

Injection system UPM 33

Intended use
Installation instructions part 2

Annex B 7

Appendix 14 / 21

Installation instructions part 3

Installation of anchor rods or Upat internal threaded anchors IST

9		<p>Only use clean and oil-free metal parts. Mark the setting depth of the metal part. Push the anchor rod or Upat internal threaded IST anchor down to the bottom of the hole, turning it slightly while doing so. After inserting the metal parts, excess mortar must be emerged around the anchor element.</p>
	<p>For overhead installations support the metal part with wedges (e. g. centering wedges) or overhead clips.</p>	<p>For push through installation fill the annular gap with mortar</p>
10	<p>Wait for the specified curing time t_{cure} see table B5.2</p>	<p>11 Mounting the fixture max T_{inst} see tables B3.1 and B4.1</p>
Option		<p>After the minimum curing time is reached, the gap between metal part and fixture (annular clearance) may be filled with mortar via the filling disc. Compressive strength $\geq 50 \text{ N/mm}^2$ (e.g. Upat injection mortars UPM 33, UPM 44, UPM 55.). ATTENTION: Using filling disc reduces t_{fix} (usable length of the anchor)</p>

Injection system UPM 33

Intended use
Installation instructions part 3

Annex B 8

Appendix 15 / 21

Table C1.1: Characteristic values for under tension / shear load of Upat anchor rods and standard threaded rods

Anchor rod / standard threaded rod		M6	M8	M10	M12	M16	M20	M24	M27	M30			
Bearing capacity under tension load, steel failure ³⁾													
Characteristic resistance $N_{Rk,s}$	Steel zinc plated	Property class	4.8	[kN]	8	15(13)	23(21)	33	63	98	141	184	224
			5.8		10	19(17)	29(27)	43	79	123	177	230	281
			8.8		16	29(27)	47(43)	68	126	196	282	368	449
	Stainless steel R and high corrosion resistant steel HCR		50		10	19	29	43	79	123	177	230	281
			70		14	26	41	59	110	172	247	322	393
			80		16	30	47	68	126	196	282	368	449
Partial factors ¹⁾													
Partial factor $\gamma_{Ms,N}$	Steel zinc plated	Property class	4.8	[-]	1,50								
			5.8		1,50								
			8.8		1,50								
	Stainless steel R and high corrosion resistant steel HCR		50		2,86								
			70		1,50 ²⁾ / 1,87								
			80		1,60								
Bearing capacity under shear load, steel failure ³⁾													
without lever arm													
Characteristic resistance $V_{Rk,s}^0$	Steel zinc plated	Property class	4.8	[kN]	4	9(8)	14(13)	20	38	59	85	110	135
			5.8		6	11(10)	17(16)	25	47	74	106	138	168
			8.8		8	15(13)	23(21)	34	63	98	141	184	225
	Stainless steel R and high corrosion resistant steel HCR		50		5	9	15	21	39	61	89	115	141
			70		7	13	20	30	55	86	124	161	197
			80		8	15	23	34	63	98	141	184	225
Ductility factor	k_7	[-]	1,0										
with lever arm													
Charact. resistance $M_{Rk,s}^0$	Steel zinc plated	Property class	4.8	[Nm]	6	15(13)	30(27)	52	133	259	448	665	899
			5.8		7	19(16)	37(33)	65	166	324	560	833	1123
			8.8		12	30(26)	60(53)	105	266	519	896	1333	1797
	Stainless steel R and high corrosion resistant steel HCR		50		7	19	37	65	166	324	560	833	1123
			70		10	26	52	92	232	454	784	1167	1573
			80		12	30	60	105	266	519	896	1333	1797
Partial factors ¹⁾													
Partial factor $\gamma_{Ms,V}$	Steel zinc plated	Property class	4.8	[-]	1.25								
			5.8		1.25								
			8.8		1.25								
	Stainless steel R and high corrosion resistant steel HCR		50		2.38								
			70		1.25 ²⁾ / 1.56								
			80		1.33								
¹⁾ In absence of other national regulations ²⁾ Only admissible for high corrosion resistant steel HCR, with $f_{yk} / f_{uk} \geq 0,8$ and $A_s > 12\%$ (e.g. Upat anchor rods) ³⁾ Values in brackets are valid for undersized threaded rods with smaller stress area A_s for hot dip galvanised standard threaded rods according to EN ISO 10684:2004+AC:2009													
Injection system UPM 33										Annex C 1 Appendix 16 / 21			
Performances Characteristic values for steel failure under tension / shear load of Upat anchor rods and standard threaded rods													

Table C2.1: Characteristic values for steel failure under tension / shear load of Upat internal threaded anchors IST

Upat internal threaded anchors IST				M8	M10	M12	M16	M20	
Bearing capacity under tension load, steel failure									
Charact. resistance with screw	$N_{Rk,s}$	Property class	5.8	[kN]	19	29	43	79	123
			8.8		29	47	68	108	179
		Property class 70	R		26	41	59	110	172
			HCR		26	41	59	110	172
Partial factors¹⁾									
Partial factors	$\gamma_{Ms,N}$	Property class	5.8	[-]	1,50				
			8.8		1,50				
		Property class 70	R		1,87				
			HCR		1,87				
Bearing capacity under shear load, steel failure									
Without lever arm									
Charact. resistance with screw	$V^0_{Rk,s}$	Property class	5.8	[kN]	9,2	14,5	21,1	39,2	62,0
			8.8		14,6	23,2	33,7	54,0	90,0
		Property class 70	R		12,8	20,3	29,5	54,8	86,0
			HCR		12,8	20,3	29,5	54,8	86,0
Ductility factor			k_7	[-]	1,0				
With lever arm									
Charact. resistance with screw	$M^0_{Rk,s}$	Property class	5.8	[Nm]	20	39	68	173	337
			8.8		30	60	105	266	519
		Property class 70	R		26	52	92	232	454
			HCR		26	52	92	232	454
Partial factors¹⁾									
Partial factors	$\gamma_{Ms,V}$	Property class	5.8	[-]	1,25				
			8.8		1,25				
		Property class 70	R		1,56				
			HCR		1,56				

¹⁾ In absence of other national regulations

Injection system UPM 33

Performances

Characteristic values for steel failure under tension / shear load of Upat internal threaded anchor IST

Annex C 2

Appendix 17 / 21

Table C3.1: Characteristic values for concrete failure under tension / shear load												
Size			All sizes									
Tension load												
Installation factor		γ_{inst}	[-]	See annex C 4 to C 5								
Factors for the compressive strength of concrete > C20/25												
Increasing factor for τ_{RK}	C25/30		Ψ_c	[-]	1,05							
	C30/37				1,10							
	C35/45				1,15							
	C40/50				1,19							
	C45/55				1,22							
	C50/60				1,26							
Splitting failure												
Edge distance	$h / h_{ef} \geq 2,0$		$C_{cr,sp}$	[mm]	1,0 h_{ef}							
	$2,0 > h / h_{ef} > 1,3$				4,6 $h_{ef} - 1,8 h$							
	$h / h_{ef} \leq 1,3$				2,26 h_{ef}							
Spacing		$S_{cr,sp}$	2 $C_{cr,sp}$									
Concrete cone failure												
Uncracked concrete		$k_{ucr,N}$	[-]	11,0								
Cracked concrete		$k_{cr,N}$		7,7								
Edge distance		$C_{cr,N}$	[mm]	1,5 h_{ef}								
Spacing		$S_{cr,N}$		2 $C_{cr,N}$								
Factors for sustained tension load												
Temperature range			[-]	50 °C / 80 °C				72 °C / 120 °C				
Factor		Ψ_{sus}^0	[-]	0,74				0,87				
Shear load												
Installation factor		γ_{inst}	[-]	1,2								
Concrete pry-out failure												
Factor for pry-out failure		k_8	[-]	2,0								
Concrete edge failure												
Effective length of fastener in shear loading		l_f	[mm]	for $d_{nom} \leq 24$ mm: min (h_{ef} ; 12 d_{nom}) for $d_{nom} > 24$ mm: min (h_{ef} ; 8 d_{nom} ; 300 mm)								
Calculation diameters												
Size			M6	M8	M10	M12	M16	M20	M24	M27	M30	
Upat anchor rods and standard threaded rods		d_{nom}	[mm]	6	8	10	12	16	20	24	27	30
Upat internal threaded anchors IST		d_{nom}		- ¹⁾	12	16	18	22	28	- ¹⁾	- ¹⁾	- ¹⁾
¹⁾ Anchor type not part of the assessment												
Injection system UPM 33									Annex C 3 Appendix 18 / 21			
Performances Characteristic values for concrete failure under tension / shear load												

Table C4.1: Characteristic values for combined pull-out and concrete failure for **Upat anchor rods** and **standard threaded rods** in hammer drilled holes; **uncracked or cracked concrete**

Anchor rod / standard threaded rod		M6	M8	M10	M12	M16	M20	M24	M27	M30		
Combined pullout and concrete cone failure												
Calculation diameter	d	[mm]	6	8	10	12	16	20	24	27	30	
Uncracked concrete												
Characteristic bond resistance in uncracked concrete C20/25												
Hammer-drilling with standard drill bit or hollow drill bit (dry or wet concrete)												
Temperature range	I: 50 °C / 80 °C	$\tau_{Rk,ucr}$	[N/mm ²]	9,0	11,0	11,0	11,0	10,0	9,5	9,0	8,5	8,5
	II: 72 °C / 120 °C			6,5	9,5	9,5	9,0	8,5	8,0	7,5	7,0	7,0
Hammer-drilling with standard drill bit or hollow drill bit (water filled hole) ¹⁾												
Temperature range	I: 50 °C / 80 °C	$\tau_{Rk,ucr}$	[N/mm ²]	-2)	-2)	-2)	9,5	8,5	8,0	7,5	7,0	7,0
	II: 72 °C / 120 °C			-2)	-2)	-2)	7,5	7,0	6,5	6,0	6,0	6,0
Installation factors												
Dry or wet concrete	γ_{inst}	[-]	1,2									
Water filled hole	γ_{inst}	[-]	-2)	-2)	-2)	1,4 ¹⁾						
Cracked concrete												
Characteristic bond resistance in cracked concrete C20/25												
Hammer-drilling with standard drill bit or hollow drill bit (dry or wet concrete)												
Temperature range	I: 50 °C / 80 °C	$\tau_{Rk,cr}$	[N/mm ²]	-2)	-2)	6,0	6,0	6,0	5,5	-2)	-2)	-2)
	II: 72 °C / 120 °C			-2)	-2)	5,0	6,0	6,0	5,0	-2)	-2)	-2)
Hammer-drilling with standard drill bit or hollow drill bit (water filled hole) ¹⁾												
Temperature range	I: 50 °C / 80 °C	$\tau_{Rk,cr}$	[N/mm ²]	-2)	-2)	-2)	5,0	5,0	4,5	-2)	-2)	-2)
	II: 72 °C / 120 °C			-2)	-2)	-2)	4,0	4,0	4,0	-2)	-2)	-2)
Installation factors												
Dry or wet concrete	γ_{inst}	[-]	1,2									
Water filled hole	γ_{inst}	[-]	-2)	-2)	-2)	1,4 ¹⁾						
¹⁾ Only with coaxial cartridges: 380ml, 400 ml, 410 ml ²⁾ No Performance assessed												

Injection system UPM 33

Performances

Characteristic values for combined pull-out and concrete failure for Upat anchor rod and standard threaded rods

Annex C 4

Appendix 19 / 21

Table C5.1: Characteristic values for combined pull-out and concrete failure for Upat internal threaded anchors IST in hammer drilled holes; uncracked concrete

Internal threaded anchor IST		M8	M10	M12	M16	M20	
Combined pullout and concrete cone failure							
Calculation diameter	d [mm]	12	16	18	22	28	
Uncracked concrete							
Characteristic bond resistance in uncracked concrete C20/25							
Hammer-drilling with standard drill bit or hollow drill bit (dry or wet concrete)							
Temperature range	I: 50 °C / 80 °C	$\tau_{Rk,ucr}$ [N/mm ²]	10,5	10,0	9,5	9,0	8,5
	II: 72 °C / 120 °C		9,0	8,0	8,0	7,5	7,0
Hammer-drilling with standard drill bit or hollow drill bit (water filled hole) ¹⁾							
Temperature range	I: 50 °C / 80 °C	$\tau_{Rk,ucr}$ [N/mm ²]	10,0	9,0	9,0	8,5	8,0
	II: 72 °C / 120 °C		7,5	6,5	6,5	6,0	6,0
Installation factors							
Dry or wet concrete	γ_{inst}	[-]	1,2				
Water filled hole			1,4 ¹⁾				

¹⁾ Only with coaxial cartridges: 380 ml, 400 ml, 410 ml

Injection system UPM 33

Performances

Characteristic values for combined pull-out and concrete failure for Upat internal threaded anchors IST

Annex C 5

Appendix 20 / 21

Table C6.1: Displacements for anchor rods

Anchor rod	M6	M8	M10	M12	M16	M20	M24	M27	M30	
Displacement-Factors for tension load¹⁾										
Uncracked concrete; Temperature range I, II										
δ_{N0} -Factor	[mm/(N/mm ²)]	0,09	0,09	0,09	0,10	0,10	0,10	0,10	0,11	0,12
$\delta_{N\infty}$ -Factor		0,10	0,10	0,10	0,12	0,12	0,12	0,12	0,13	0,13
Cracked concrete; Temperature range I, II										
δ_{N0} -Factor	[mm/(N/mm ²)]	- ³⁾	- ³⁾	0,12	0,12	0,13	0,13	- ³⁾	- ³⁾	- ³⁾
δ_{N0} -Factor		- ³⁾	- ³⁾	0,27	0,30	0,30	0,30	- ³⁾	- ³⁾	- ³⁾
Displacement-Factors for shear load²⁾										
Uncracked or cracked concrete; Temperature range I, II										
δ_{V0} -Factor	[mm/kN]	0,11	0,11	0,11	0,10	0,10	0,09	0,09	0,08	0,07
$\delta_{V\infty}$ -Factor		0,12	0,12	0,12	0,11	0,11	0,10	0,10	0,09	0,09
¹⁾ Calculation of effective displacement: $\delta_{N0} = \delta_{N0}\text{-Factor} \cdot \tau_{Ed}$ $\delta_{N\infty} = \delta_{N\infty}\text{-Factor} \cdot \tau_{Ed}$ (τ_{Ed} : Design value of the applied tensile stress) ³⁾ No performance assessed					²⁾ Calculation of effective displacement: $\delta_{V0} = \delta_{V0}\text{-Factor} \cdot V_{Ed}$ $\delta_{V\infty} = \delta_{V\infty}\text{-Factor} \cdot V_{Ed}$ (V_{Ed} : Design value of the applied shear force)					

Table C6.2: Displacements for Upat internal threaded anchors IST

Internal threaded anchor IST	M8	M10	M12	M16	M20	
Displacement-Factors for tension load¹⁾						
Uncracked concrete; Temperature range I, II						
δ_{N0} -Factor	[mm/(N/mm ²)]	0,10	0,11	0,12	0,13	0,14
$\delta_{N\infty}$ -Factor		0,13	0,14	0,15	0,16	0,18
Displacement-Factors for shear load²⁾						
Uncracked concrete; Temperature range I, II						
δ_{V0} -Factor	[mm/kN]	0,12	0,12	0,12	0,12	0,12
$\delta_{V\infty}$ -Factor		0,14	0,14	0,14	0,14	0,14
¹⁾ Calculation of effective displacement: $\delta_{N0} = \delta_{N0}\text{-Factor} \cdot \tau_{Ed}$ $\delta_{N\infty} = \delta_{N\infty}\text{-Factor} \cdot \tau_{Ed}$ (τ_{Ed} : Design value of the applied tensile stress)			²⁾ Calculation of effective displacement: $\delta_{V0} = \delta_{V0}\text{-Factor} \cdot V_{Ed}$ $\delta_{V\infty} = \delta_{V\infty}\text{-Factor} \cdot V_{Ed}$ (V_{Ed} : Design value of the applied shear force)			

Injection system UPM 33	Annex C 6 Appendix 21 / 21
Performances Displacements for anchor rods and Upat internal threaded anchors IST	