



DECLARATION OF PERFORMANCE

DoP 0201

for Upat injection system UPM44 (Bonded fastener for use in concrete)

EN

1. <u>Unique identification code of the product-type:</u>	<b>DoP 0201</b>		
2. <u>Intended use/es:</u>	<b>Post-installed fastening in cracked or uncracked concrete.</b>		
3. <u>Manufacturer:</u>	<b>See appendix, especially annexes B1- B10</b>		
	<b>Upat Vertriebs GmbH, Bebelstraße 11, 79108 Freiburg im Breisgau, Germany</b>		
4. <u>Authorised representative:</u>	–		
5. <u>System/s of AVCP:</u>	1		
6. <u>European Assessment Document:</u>	<b>EAD 330499-01-0601, Edition 04/2020</b>		
European Technical Assessment:	<b>ETA-02/0022; 2020-07-28</b>		
Technical Assessment Body:	<b>DIBt- Deutsches Institut für Bautechnik</b>		
Notified body/ies:	<b>2873 TU Darmstadt</b>		
7. <u>Declared performance/s:</u>			
<b>Mechanical resistance and stability (BWR 1)</b>			
Characteristic resistance to tension load (static and quasi-static loading):	Resistance to steel failure:	Annexes C1-C3	$E_s = 210\,000\text{ MPa}$
	Resistance to combined pull- out and concrete cone failure:	Annexes C5-C8	$\tau_{Rk,100} = \text{NPD}$
	Resistance to concrete cone failure:	Annex C4	
	Edge distance to prevent splitting under load:	Annex C4	
	Robustness:	Annexes C4-C8,C13,C14	
	Maximum installation torque:	Annexes B3, B4, B6	
	Minimum edge distance and spacing:	Annexes B3- B6	
Characteristic resistance to shear load (static and quasi-static loading):	Resistance to steel failure:	Annexes C1- C3	
	Resistance to pry-out failure:	Annex C4	
	Resistance to concrete edge failure:	Annex C4	
Characteristic resistance and displacements for seismic performance categories C1 and C2:	Resistance to tension load, displacements, category C1:	Annexes C11-C13	
	Resistance to tension load, displacements, category C2:	Annexes C11,C12,C14	
	Resistance to shear load, displacements, category C1:	Annexes C11,C12	
	Resistance to shear load, displacements, category C2:	Annexes C11,C12,C14	
	Factor annular gap:	Annex C11	
Displacements under short-term and long-term loading:	Displacements under short-term and long-term loading:	Annexes C9, C10	
<b>Hygiene, health and the environment (BWR 3)</b>			
Content, emission and/or release of dangerous substances:	NPD		



Einfach. Sicher.



8. Appropriate Technical Documentation and/or -  
Specific Technical Documentation:

The performance of the product identified above is in conformity with the set of declared performance/s. This declaration of performance is issued, in accordance with Regulation (EU) No 305/2011, under the sole responsibility of the manufacturer identified above.

Signed for and on behalf of the manufacturer by:

Dr. Oliver Geibig, Managing Director Business Units & Engineering  
Tumlingen, 2020-08-11

Jürgen Grün, Managing Director Chemistry & Quality

This DoP has been prepared in different languages. In case there is a dispute on the interpretation the English version shall always prevail.

The Appendix includes voluntary and complementary information in English language exceeding the (language-neutrally specified) legal requirements.

## Specific Part

### 1 Technical description of the product

The "injection system UPM 44" is a bonded fastener consisting of a cartridge with injection mortar UPM 44, UPM 44 Relax or UPM 44 Express and a steel element according to Annex A5.

The steel element is placed into a drilled hole filled with injection mortar and is anchored via the bond between metal part, injection mortar and concrete.

The product description is given in Annex A.

### 2 Specification of the intended use in accordance with the applicable European Assessment Document

The performances given in Section 3 are only valid if the anchor is used in compliance with the specifications and conditions given in Annex B.

The verifications and assessment methods on which this European Technical Assessment is based lead to the assumption of a working life of the anchor of at least 50 years. The indications given on the working life cannot be interpreted as a guarantee given by the producer, but are to be regarded only as a means for choosing the right products in relation to the expected economically reasonable working life of the works.

### 3 Performance of the product and references to the methods used for its assessment

#### 3.1 Mechanical resistance and stability (BWR 1)

Essential characteristic	Performance
Characteristic resistance to tension load (static and quasi-static loading)	See Annex B 3 to B 6, C 1 to C 8
Characteristic resistance to shear load (static and quasi-static loading)	See Annex C 1 to C 4
Displacements under short-term and long-term loading	See Annex C 9 and C 10
Characteristic resistance and displacements for seismic performance categories C1 and C2	See Annex C 11 to C 14

#### 3.2 Hygiene, health and the environment (BWR 3)

Essential characteristic	Performance
Content, emission and/or release of dangerous substances	No performance assessed

**4 Assessment and verification of constancy of performance (AVCP) system applied, with reference to its legal base**

In accordance with the European Assessment Document EAD 330499-01-0601 the applicable European legal act is: [96/582/EC].

The system to be applied is: 1

# Installation conditions part 1

## Upat anchor rod

### Pre-positioned installation

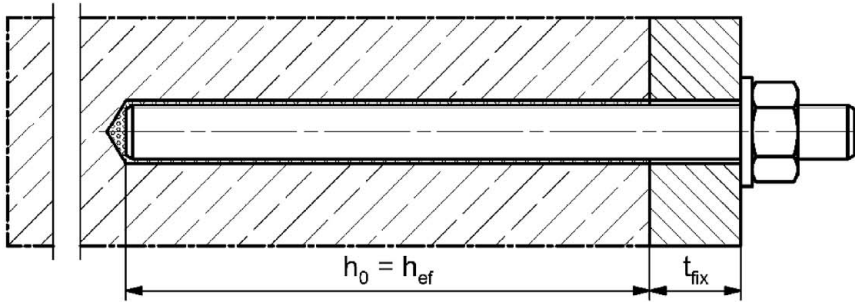

### Push through installation (annular gap filled with mortar)

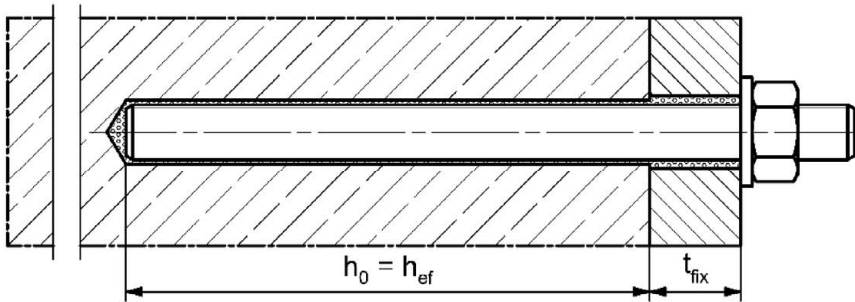

### Pre-positioned or push through installation with subsequently injected filling disc (annular gap filled with mortar)

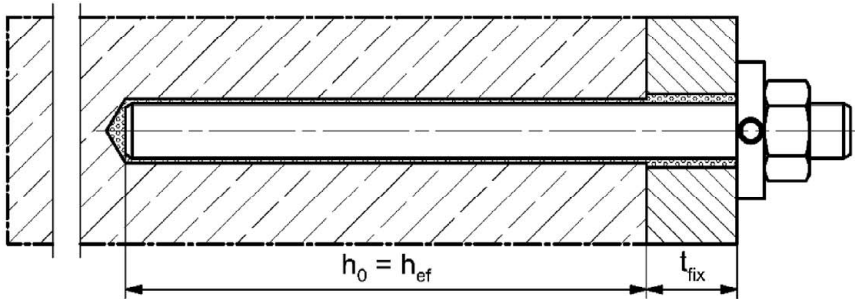

Figures not to scale

$h_0$  = drill hole depth

$h_{ef}$  = effective embedment depth

$t_{fix}$  = thickness of fixture

injection system UPM 44

**Product description**  
Installation conditions part 1

**Annex A 1**

Appendix 3 / 32

## Installation conditions part 2

### Upat Internal threaded anchor IST

#### Pre-positioned installation

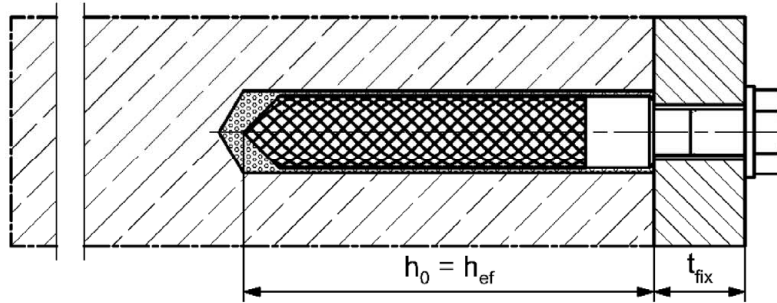

#### Pre-positioned installation with subsequently injected filling disc (annular gap filled with mortar)

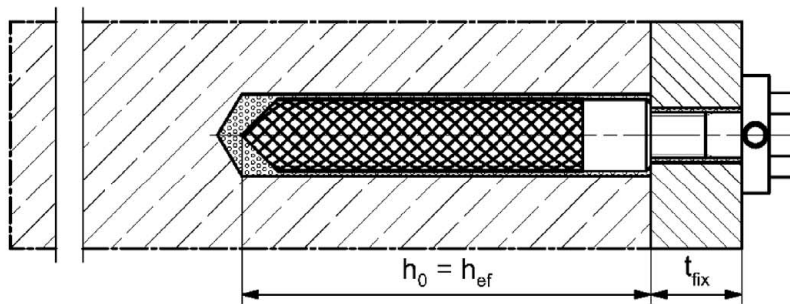

Figures not to scale

$h_0$  = drill hole depth

$h_{ef}$  = effective embedment depth

$t_{fix}$  = thickness of fixture

injection system UPM 44

**Product description**  
Installation conditions part 2

**Annex A 2**

Appendix 4 / 32

# Installation conditions part 3

## Reinforcing bar

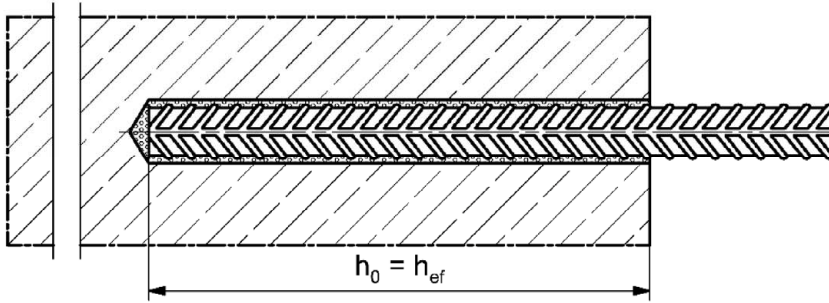

## Upat rebar anchor FRA

### Pre-positioned installation

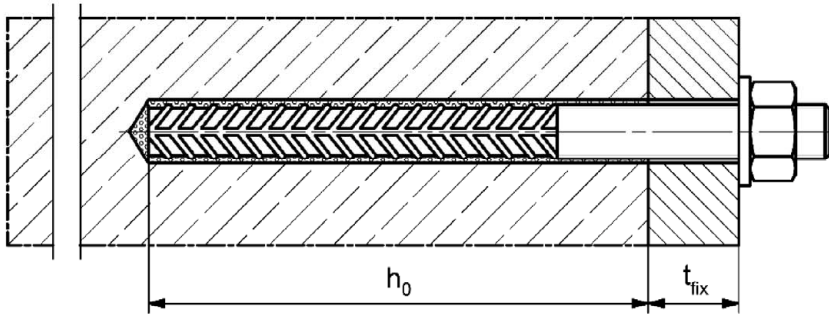

### Push through installation (annular gap filled with mortar)

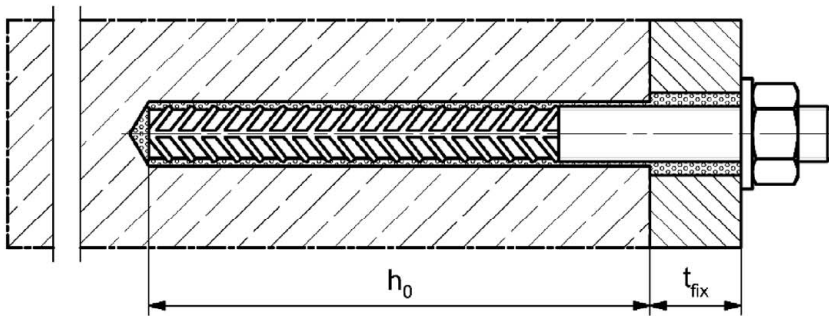

Figures not to scale

$h_0$  = drill hole depth

$h_{ef}$  = effective embedment depth

$t_{fix}$  = thickness of fixture

injection system UPM 44

**Product description**  
Installation conditions part 3

**Annex A 3**

Appendix 5 / 32

# Overview system components part 1

**Injection cartridge (shuttle cartridge) with sealing cap; Sizes: 350 ml, 360 ml, 390 ml, 550 ml, 1100 ml, 1500 ml**

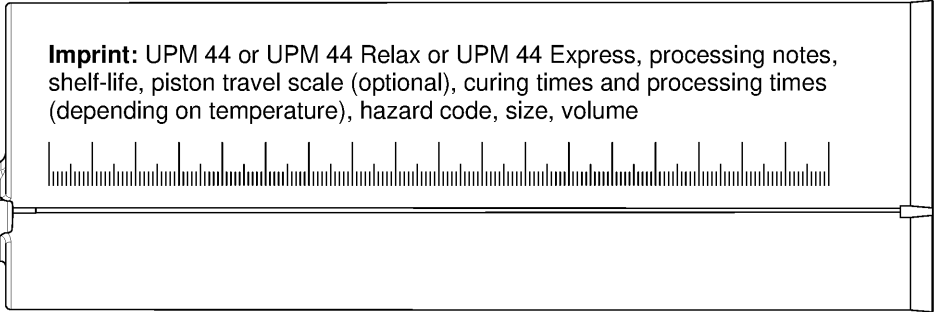
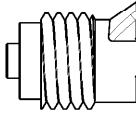
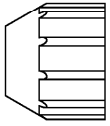

**Injection cartridge (coaxial cartridge) with sealing cap; Sizes: 100 ml, 150 ml, 300 ml, 380 ml, 400 ml, 410 ml**

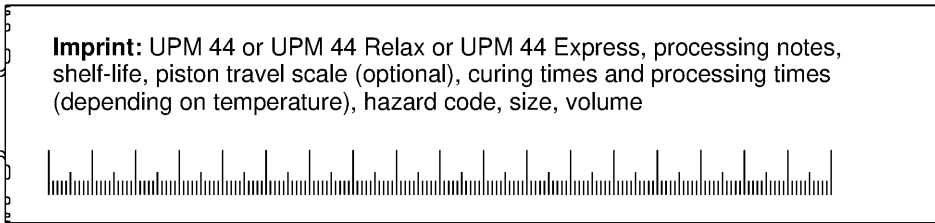
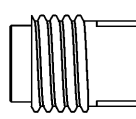
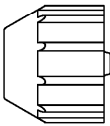

**Static mixer Upat MR Plus or UMR**

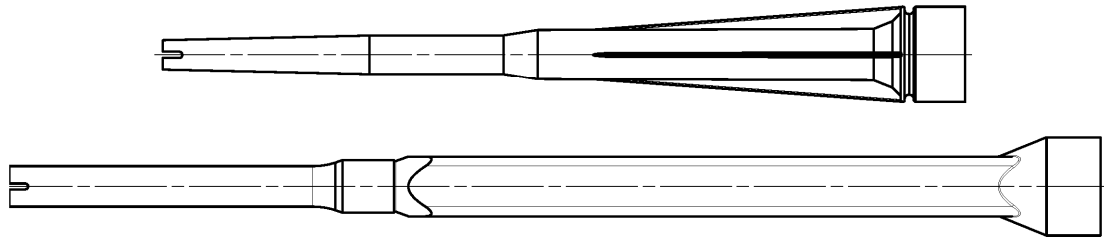

**Injection adapter and Extension tube for static mixer**

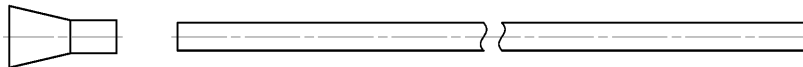

**Cleaning brush UP BS**



**Blow-out pump UPM or ABP**



Figures not to scale

injection system UPM 44

**Product description**

Overview system components part 1;  
cartridges / static mixer / accessories

**Annex A 4**

Appendix 6 / 32



## Overview system components part 2

### Upat anchor rod

Size: M6, M8, M10, M12, M16, M20, M24, M27, M30

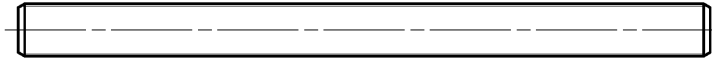

### Upat internal threaded anchor IST

Size: M8, M10, M12, M16, M20



### Screw / threaded rod / washer / hexagon nut

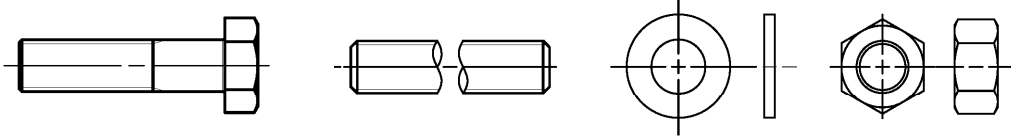

### Filling disc with injection adapter

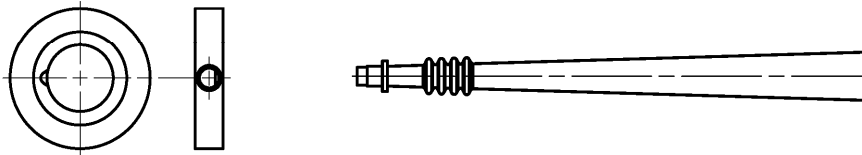

### Reinforcing bar

Nominal diameter:  $\phi 8$ ,  $\phi 10$ ,  $\phi 12$ ,  $\phi 14$ ,  $\phi 16$ ,  $\phi 20$ ,  $\phi 25$ ,  $\phi 28$



### Upat rebar anchor FRA

Size: M12, M16, M20, M24



Figures not to scale

injection system UPM 44

### Product description

Overview system components part 2;  
steel components







**Annex A 5**

Appendix 7 / 32

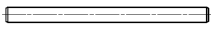
<b>Table A6.1: Materials</b>				
<b>Part</b>	<b>Designation</b>	<b>Material</b>		
1	Injection cartridge	Mortar, hardener, filler		
	Steel grade	Steel	Stainless steel R	High corrosion resistant steel HCR
		zinc plated	acc. to EN 10088-1:2014 Corrosion resistance class CRC III acc. to EN 1993-1-4:2015	acc. to EN 10088-1:2014 Corrosion resistance class CRC V acc. to EN 1993-1-4:2015
2	Anchor rod	Property class 4.8, 5.8 or 8.8; EN ISO 898-1:2013 zinc plated $\geq 5 \mu\text{m}$ , ISO 4042:2018/Zn5/An(A2K) or hot dip galvanised $\geq 40 \mu\text{m}$ EN ISO 10684:2004 $f_{uk} \leq 1000 \text{ N/mm}^2$ $A_5 > 12\%$ fracture elongation	Property class 50, 70 or 80 EN ISO 3506-1:2009 1.4401; 1.4404; 1.4578; 1.4571; 1.4439; 1.4362; 1.4062, 1.4662, 1.4462; EN 10088-1:2014 $f_{uk} \leq 1000 \text{ N/mm}^2$ $A_5 > 12\%$ fracture elongation	Property class 50 or 80 EN ISO 3506-1:2009 or property class 70 with $f_{yk} = 560 \text{ N/mm}^2$ 1.4565; 1.4529; EN 10088-1:2014 $f_{uk} \leq 1000 \text{ N/mm}^2$ $A_5 > 12\%$ fracture elongation
		Fracture elongation $A_5 > 8\%$ , for applications without requirements for seismic performance category C2		
3	Washer ISO 7089:2000	zinc plated $\geq 5 \mu\text{m}$ , ISO 4042:2018/Zn5/An(A2K) or hot dip galvanised $\geq 40 \mu\text{m}$ EN ISO 10684:2004	1.4401; 1.4404; 1.4578; 1.4571; 1.4439; 1.4362; EN 10088-1:2014	1.4565; 1.4529; EN 10088-1:2014
4	Hexagon nut	Property class 4, 5 or 8; EN ISO 898-2:2012 zinc plated $\geq 5 \mu\text{m}$ , ISO 4042:2018/Zn5/An(A2K) or hot dip galvanised $\geq 40 \mu\text{m}$ EN ISO 10684:2004	Property class 50, 70 or 80 EN ISO 3506-1:2009 1.4401; 1.4404; 1.4578; 1.4571; 1.4439; 1.4362; EN 10088-1:2014	Property class 50, 70 or 80 EN ISO 3506-1:2009 1.4565; 1.4529 EN 10088-1:2014
5	Upat internal threaded anchor IST	Property class 5.8 ISO 898-1:2013 zinc plated $\geq 5 \mu\text{m}$ , ISO 4042:2018/Zn5/An(A2K)	Property class 70 EN ISO 3506-1:2009 1.4401; 1.4404; 1.4578; 1.4571; 1.4439; 1.4362; EN 10088-1:2014	Property class 70 EN ISO 3506-1:2009 1.4565; 1.4529; EN 10088-1:2014
6	Commercial standard screw or threaded rod for Upat internal threaded anchor IST	Property class 5.8 or 8.8; EN ISO 898-1:2013 zinc plated $\geq 5 \mu\text{m}$ , ISO 4042:2018/Zn5/An(A2K) $A_5 > 8\%$ fracture elongation	Property class 70 EN ISO 3506-1:2009 1.4401; 1.4404; 1.4578; 1.4571; 1.4439; 1.4362; EN 10088-1:2014 $A_5 > 8\%$ fracture elongation	Property class 70 EN ISO 3506-1:2009 1.4565; 1.4529; EN 10088-1:2014 $A_5 > 8\%$ fracture elongation
7	filling disc similar to DIN 6319-G	zinc plated $\geq 5 \mu\text{m}$ , ISO 4042:2018/Zn5/An(A2K) or hot dip galvanised $\geq 40 \mu\text{m}$ EN ISO 10684:2004	1.4401; 1.4404; 1.4578; 1.4571; 1.4439; 1.4362; EN 10088-1:2014	1.4565; 1.4529; EN 10088-1:2014
8	Reinforcing bar EN 1992-1-1:2004 and AC:2010, Annex C	Bars and de-coiled rods, class B or C with $f_{yk}$ and $k$ according to NDP or NCL of according to EN 1992-1-1/NA $f_{uk} = f_{tk} = k \cdot f_{yk}$		
9	Upat rebar anchor FRA	Rebar part: Bars and de-coiled rods class B or C with $f_{yk}$ and $k$ according to NDP or NCL of EN 1992-1-1:2004+AC:2010 $f_{uk} = f_{tk} = k \cdot f_{yk}$	Threaded part: Property class 70 or 80 EN ISO 3506-1:2009 1.4401, 1.4404, 1.4571, 1.4578, 1.4439, 1.4362, 1.4062 acc. to EN 10088-1:2014 Corrosion resistance class CRC III acc. to EN 1993-1-4:2015 1.4565; 1.4529 acc. to EN 10088-1:2014 Corrosion resistance class CRC V acc. to EN 1993-1-4:2015	
injection system UPM 44				<b>Annex A 6</b>  Appendix 8 / 32
<b>Product description</b> Materials				

# Specifications of intended use (part 1)

**Table B1.1:** Overview use and performance categories

Anchorages subject to		UPM 44 with ...							
		Anchor rod 	Upat internal threaded anchor IST 		Reinforcing bar 		Upat rebar anchor FRA 		
Hammer drilling with standard drill bit 		all sizes							
Hammer drilling with hollow drill bit (fischer "FHD", Heller "Duster Expert"; Bosch „Speed Clean“; Hilti "TE-CD, TE-YD"), DreBo D-Plus, DreBo D-Max 		Nominal drill bit diameter ( $d_0$ ) 12 mm to 35 mm							
Static and quasi static load, in	uncracked concrete	all sizes	Tables: C1.1 C4.1	all sizes	Tables: C2.1 C4.1	all sizes	Tables: C3.1 C4.1	all sizes	Tables: C3.2 C4.1
	cracked concrete	M8 to M30	C5.1 C9.1	-2)	C6.1 C9.2	$\phi$ 10 to $\phi$ 28	C7.1 C10.1		C8.1 C10.2
Seismic performance category (only hammer drilling with standard / hollow drill bits)	C1 <sup>1)</sup>	M10 to M30	Tables: C11.1 C12.1 C13.1	-2)	-2)	-2)	-2)	-2)	-2)
	C2 <sup>1)</sup>	M12 M16 M20 M24	Tables: C11.1 C12.1 C14.1						
Use category	I1 dry or wet concrete	all sizes							
	I2 water filled hole	M 12 to M 30		all sizes		-2)		-2)	
Installation direction	D3 (downward and horizontal and upwards (e.g. overhead) installation)								
Installation temperature	$T_{i,min} = -10\text{ °C}$ to $T_{i,max} = +40\text{ °C}$								
In-service temperature	Temperature range I	-40 °C to +80 °C		(max. short term temperature +80 °C; max. long term temperature +50 °C)					
	Temperature range II	-40 °C to +120 °C		(max. short term temperature +120 °C; max. long term temperature +72 °C)					

<sup>1)</sup> Not for UPM 44 Relax or UPM 44 Express

<sup>2)</sup> No performance assessed

injection system UPM 44

**Intended use**  
Specifications (part 1)

**Annex B 1**

Appendix 9 / 32

## Specifications of intended use (part 2)

### Base materials:

- Compacted reinforced or unreinforced normal weight concrete without fibres of strength classes C20/25 to C50/60 according to EN 206:2013+A1:2016

### Use conditions (Environmental conditions):

- Structures subject to dry internal conditions (zinc coated steel, stainless steel or high corrosion resistant steel).
- For all other conditions according to EN1993-1-4:2015 corresponding to corrosion resistance classes to Annex A 6 table A6.1.

### Design:

- Anchorages have to be designed by a responsible engineer with experience of concrete anchor design.
- Verifiable calculation notes and drawings are to be prepared taking account of the loads to be anchored. The position of the anchor is indicated on the design drawings (e. g. position of the anchor relative to reinforcement or to supports, etc.).
- Anchorages are designed in accordance with: EN 1992-4:2018 and EOTA Technical Report TR 055, Edition February 2018.

### Installation:

- Anchor installation is to be carried out by appropriately qualified personnel and under the supervision of the person responsible for technical matters of the site
- In case of aborted hole: The hole shall be filled with mortar
- Anchorage depth should be marked and adhered to on installation
- Overhead installation is allowed

injection system UPM 44

**Intended use**  
Specifications (part 2)

**Annex B 2**

Appendix 10 / 32

**Table B3.1: Installation parameters for anchor rods**

Anchor rods		Thread	M6	M8	M10	M12	M16	M20	M24	M27	M30	
Width across flats	SW	[mm]	10	13	17	19	24	30	36	41	46	
Nominal drill hole diameter	$d_0$		8	10	12	14	18	24	28	30	35	
Drill hole depth	$h_0$		$h_0 = h_{ef}$									
Effective embedment depth	$h_{ef, min}$		50	60	60	70	80	90	96	108	120	
	$h_{ef, max}$		72	160	200	240	320	400	480	540	600	
Minimum spacing and minimum edge distance	$s_{min} = c_{min}$		40	40	45	55	65	85	105	125	140	
Diameter of the clearance hole of the fixture	pre-positioned installation $d_f$		7	9	12	14	18	22	26	30	33	
	push through installation $d_f$		9	12	14	16	20	26	30	33	40	
Minimum thickness of concrete member	$h_{min}$		$h_{ef} + 30 (\geq 100)$					$h_{ef} + 2d_0$				
Maximum installation torque	$\max T_{inst}$		[Nm]	5	10	20	40	60	120	150	200	300

**Upat anchor rod**

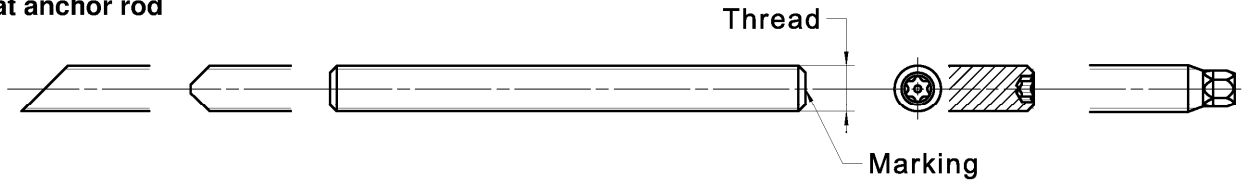

**Marking (on random place) Upat anchor rod:**

Steel zinc plated PC <sup>1)</sup> 8.8	• or +	Steel hot-dip PC <sup>1)</sup> 8.8	•
High corrosion resistant steel HCR PC <sup>1)</sup> 50	•	High corrosion resistant steel HCR PC <sup>1)</sup> 70	-
High corrosion resistant steel HCR PC <sup>1)</sup> 80	(	Stainless steel R property class 50	~
Stainless steel R property class 80	*		
Alternatively: Colour coding according to DIN 976-1: 2016		1) PC = property class	

**Installation conditions:**

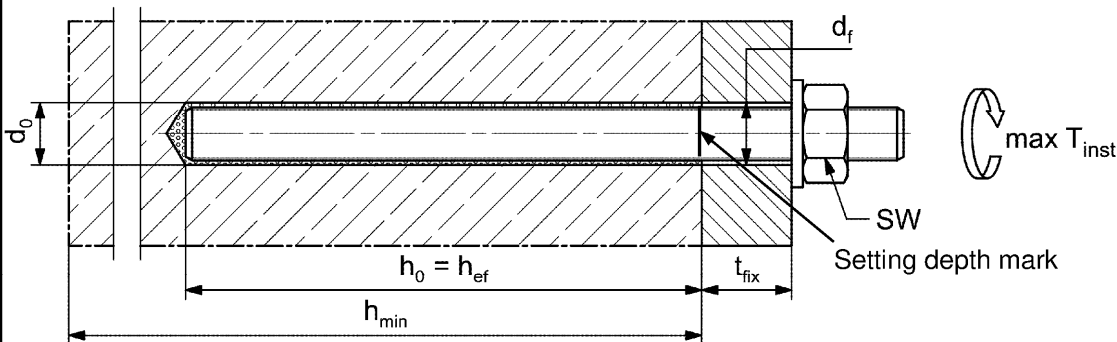

**Commercial standard threaded rods, washers and hexagon nuts may also be used if the following requirements are fulfilled**

- Materials, dimensions and mechanical properties according to Annex A 6, Table A6.1
- Inspection certificate 3.1 according to EN 10204:2004, the documents have to be stored
- Setting depth is marked

Figures not to scale

injection system UPM 44

**Intended use**  
Installation parameters anchor rods

**Annex B 3**

Appendix 11 / 32

**Table B4.1: Installation parameters for Upat internal threaded anchors IST**

Internal threaded anchors IST		Thread	M8	M10	M12	M16	M20
Diameter of anchor	$d_{nom} = d_H$	[mm]	12	16	18	22	28
Nominal drill hole diameter	$d_0$		14	18	20	24	32
Drill hole depth	$h_0$		$h_0 = h_{ef} = L_H$				
Effective embedment depth ( $h_{ef} = L_H$ )	$h_{ef}$		90	90	125	160	200
Minimum spacing and minimum edge distance	$s_{min} = c_{min}$		55	65	75	95	125
Diameter of clearance hole in the fixture	$d_f$		9	12	14	18	22
Minimum thickness of concrete member	$h_{min}$		120	125	165	205	260
Maximum screw-in depth	$l_{E,max}$		18	23	26	35	45
Minimum screw-in depth	$l_{E,min}$	8	10	12	16	20	
Maximum installation torque	$\max T_{inst}$	[Nm]	10	20	40	80	120

**Upat internal threaded anchor IST**

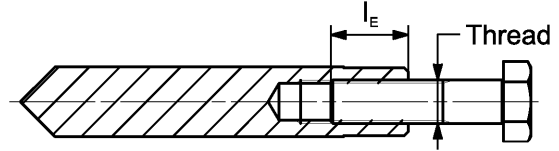
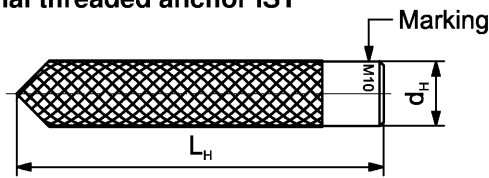

**Marking:** Anchor size e. g.: **M10**  
 Stainless steel → additional **R**; e.g.: **M10 R**  
 High corrosion resistant steel → additional **HCR**; e.g.: **M10 HCR**

Retaining bolt or threaded rods (including nut and washer) must comply with the appropriate material and strength class of Annex A 6, Table A6.1

**Installation conditions:**

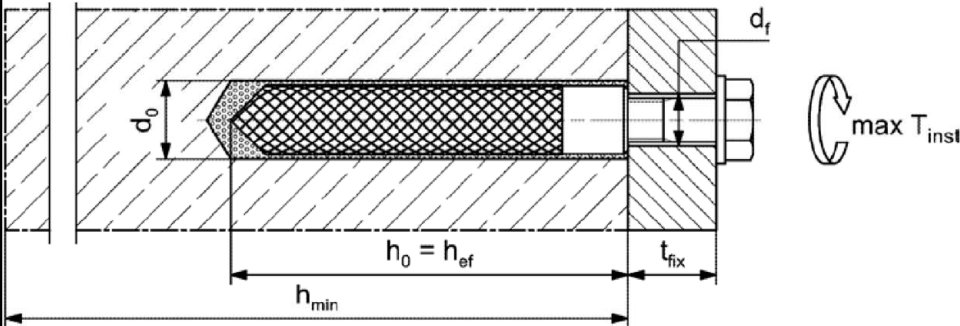

Figures not to scale

injection system UPM 44

**Intended use**  
 Installation parameters Upat internal threaded anchors IST

**Annex B 4**

Appendix 12 / 32

**Table B5.1: Installation parameters for reinforcing bars**

Nominal diameter of the bar		$\phi$	8 <sup>1)</sup>		10 <sup>1)</sup>		12 <sup>1)</sup>		14	16	20	25	28	
Nominal drill hole diameter	$d_0$	[mm]	10	12	12	14	14	16	18	20	25	30	35	
Drill hole depth	$h_0$		$h_0 = h_{ef}$											
Effective embedment depth	$h_{ef,min}$		60	60	70	75	80	90	100	112				
	$h_{ef,max}$		160	200	240	280	320	400	500	560				
Minimum spacing and minimum edge distance	$s_{min}$ = $c_{min}$		40	45	55	60	65	85	110	130				
Minimum thickness of concrete member	$h_{min}$	$h_{ef} + 30$ ( $\geq 100$ )					$h_{ef} + 2d_0$							

1) Both drill hole diameters can be used

**Reinforcing bar**



- The minimum value of related rib area  $f_{R,min}$  must fulfil the requirements of EN 1992-1-1:2004+AC:2010
- The rib height must be within the range:  $0,05 \cdot \phi \leq h_{rib} \leq 0,07 \cdot \phi$   
( $\phi$  = Nominal diameter of the bar,  $h_{rib}$  = rib height)

**Installation conditions:**

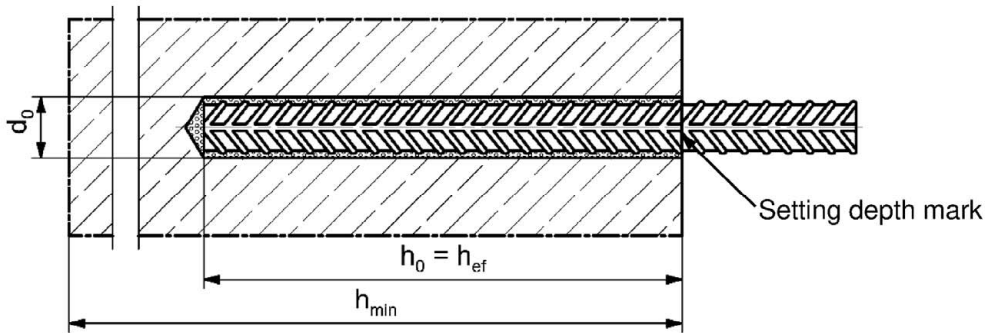

Figures not to scale

injection system UPM 44

**Intended use**  
Installation parameters reinforcing bars

**Annex B 5**

Appendix 13 / 32



**Table B6.1: Installation parameters for Upat rebar anchor FRA**

Rebar anchor FRA		Thread	M12 <sup>1)</sup>	M16	M20	M24
Nominal diameter of the bar	$\phi$	[mm]	12	16	20	25
Width across flats	SW		19	24	30	36
Nominal drill hole diameter	$d_0$		14	16	20	30
Drill hole depth	$h_0$		$h_{ef} + l_e$			
Effective embedment depth	$h_{ef,min}$		70	80	90	96
	$h_{ef,max}$		140	220	300	380
Distance concrete surface to welded joint	$l_e$		100			
Minimum spacing and minimum edge distance	$S_{min}$		55	65	85	105
	$C_{min}$					
Diameter of clearance hole in the fixture	pre-positioned anchorage $\leq d_r$		14	18	22	26
	push through anchorage $\leq d_r$	18	22	26	32	
Minimum thickness of concrete member	$h_{min}$	$h_0 + 30$	$h_0 + 2d_0$			
Maximum installation torque	$\max T_{inst}$	[Nm]	40	60	120	150

<sup>1)</sup> Both drill hole diameters can be used

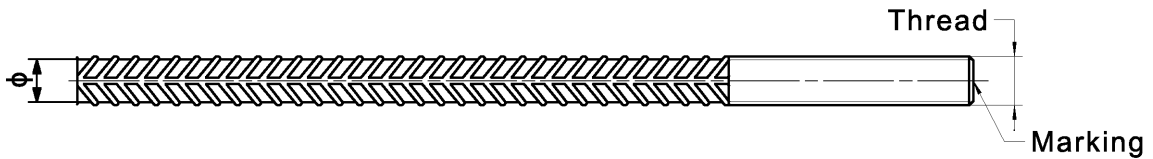
**Upat rebar anchor FRA**



Marking frontal e. g:  FRA (for stainless steel);  
 FRA HCR (for high corrosion resistant steel)

**Installation conditions:**

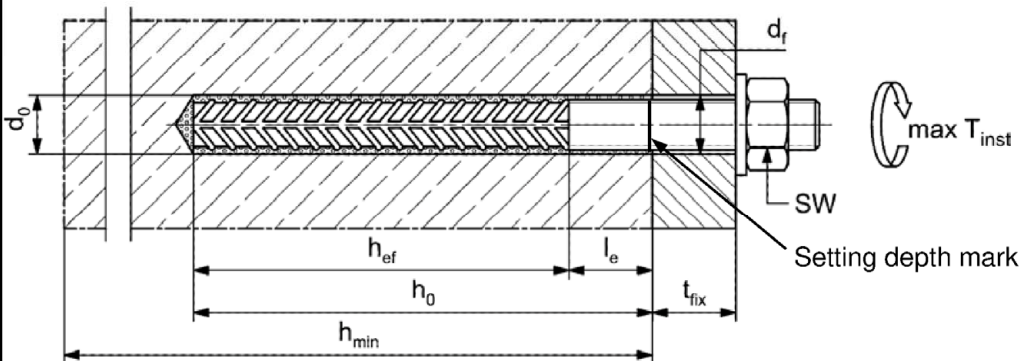

Figures not to scale

injection system UPM 44

**Intended use**  
Installation parameters rebar anchor FRA

**Annex B 6**

Appendix 14 / 32



**Table B7.1:** Parameters of the **cleaning brush UP BS** (steel brush with steel bristles)

The size of the cleaning brush refers to the drill hole diameter

Nominal drill hole diameter	$d_0$	[mm]	8	10	12	14	16	18	20	24	25	28	30	35
Steel brush diameter	$d_b$		9	11	14	16	20		25	26	27	30	40	

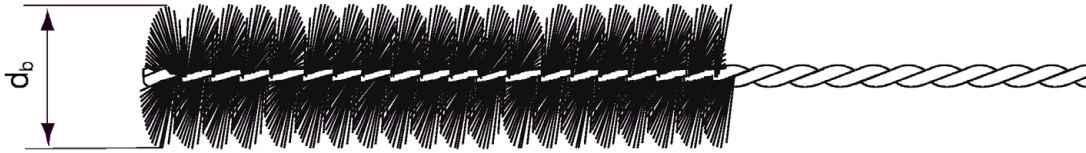

**Table B7.2** **Maximum processing** time of the mortar and **minimum curing** time  
(During the curing time of the mortar the concrete temperature may not fall below the listed minimum temperature)

Temperature at anchoring base [°C]	Maximum processing time $t_{work}$			Minimum curing time $t_{cure}$ <sup>1)</sup>		
	UPM 44 Express	UPM 44	UPM 44 Relax	UPM 44 Express	UPM 44	UPM 44 Relax
-10 to -5 <sup>2)</sup>	-	-	-	12 h	-	-
> -5 to 0 <sup>2)</sup>	5 min	-	-	3 h	24 h	-
> 0 to 5 <sup>2)</sup>	5 min	13 min	-	3 h	3 h	6 h
> 5 to 10	3 min	9 min	20 min	50 min	90 min	3 h
> 10 to 20	1 min	5 min	10 min	30 min	60 min	2 h
> 20 to 30	-	4 min	6 min	-	45 min	60 min
> 30 to 40	-	2 min	4 min	-	35 min	30 min

<sup>1)</sup> In wet concrete or water filled holes the curing times must be doubled

<sup>2)</sup> Minimal cartridge temperature +5°C

injection system UPM 44

**Intended use**

Cleaning brush (steel brush)  
Processing time and curing time

**Annex B 7**

# Installation instructions part 1

## Drilling and cleaning the hole (hammer drilling with standard drill bit)

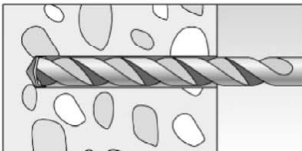
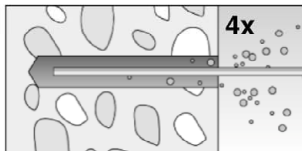
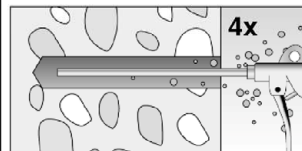
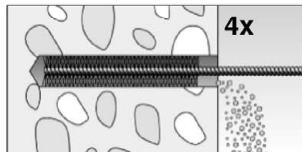
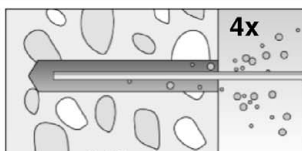
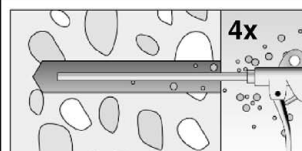
1		<p>Drill the hole. Nominal drill hole diameter <math>d_0</math> and drill hole depth <math>h_0</math> see <b>tables B3.1, B4.1, B5.1, B6.1</b></p>	
2		<p>Clean the drill hole: For <math>h_{ef} \leq 12d</math> and <math>d_0 &lt; 18</math> mm blow out the hole four times by hand</p>	 <p>For <math>h_{ef} &gt; 12d</math> and / or <math>d_0 \geq 18</math> mm blow out the hole four times with oil-free compressed air (<math>p \geq 6</math> bar)</p>
3		<p>Brush the drill hole four times. For deep holes use an extension. Corresponding brushes see <b>table B7.1</b></p>	
4		<p>Clean the drill hole: For <math>h_{ef} \leq 12d</math> and <math>d_0 &lt; 18</math> mm blow out the hole four times by hand</p>	 <p>For <math>h_{ef} &gt; 12d</math> and / or <math>d_0 \geq 18</math> mm blow out the hole four times with oil-free compressed air (<math>p \geq 6</math> bar)</p>

Go to step 5

## Drilling and cleaning the hole (hammer drilling with hollow drill bit)

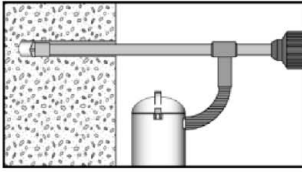
1		<p>Check a suitable hollow drill (see <b>table B1.1</b>) for correct operation of the dust extraction</p>
2		<p>Use a suitable dust extraction system, e. g. fischer FVC 35 M or a comparable dust extraction system with equivalent performance data</p> <p>Drill the hole with hollow drill bit. The dust extraction system has to extract the drill dust nonstop during the drilling process and must be adjusted to maximum power. Nominal drill hole diameter <math>d_0</math> and drill hole depth <math>h_0</math> see <b>tables B3.1, B4.1, B5.1, B6.1</b></p>

Go to step 5

injection system UPM 44



**Intended use**  
Installation instructions part 1

**Annex B 8**

Appendix 16 / 32

## Installation instructions part 2

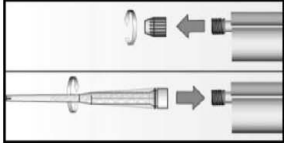
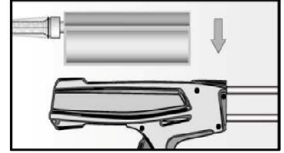
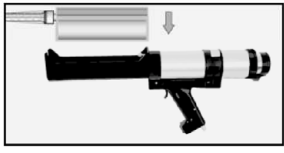
### Preparing the cartridge

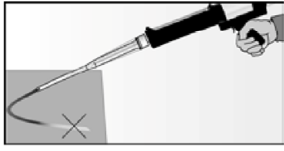
5		Remove the sealing cap Screw on the static mixer (the spiral in the static mixer must be clearly visible)
6		 Place the cartridge into the dispenser
7		 Extrude approximately 10 cm of material out until the resin is evenly grey in colour. Do not use mortar that is not uniformly grey

Go to step 8

### Injection of the mortar

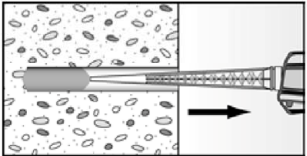
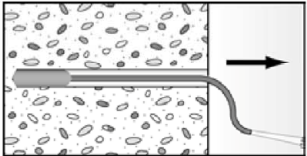
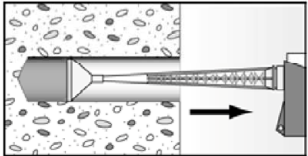
8	 <p>Fill approximately 2/3 of the drill hole with mortar. Always begin from the bottom of the hole and avoid bubbles</p>	 <p>For drill hole depth <math>\geq 150</math> mm use an extension tube</p>	 <p>For overhead installation, deep holes (<math>h_0 &gt; 250</math> mm) or drill hole diameter (<math>d_0 \geq 40</math> mm) use an injection adapter</p>
---	---	--	---

Go to step 9

injection system UPM 44



**Intended use**  
Installation instructions part 2

**Annex B 9**

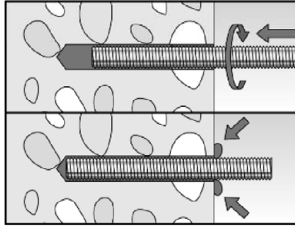
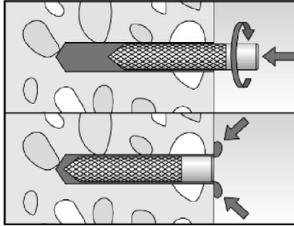
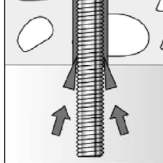
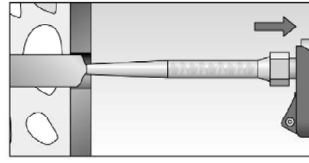

Appendix 17 / 32

### Installation instructions part 3

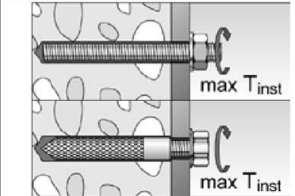
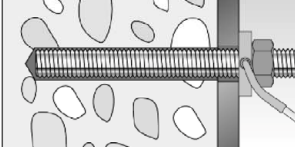
#### Installation of anchor rods or Upat internal threaded anchors IST

9			<p>Only use clean and oil-free metal parts. Mark the setting depth of the metal part. Push the anchor rod or Upat internal threaded IST anchor down to the bottom of the hole, turning it slightly while doing so. After inserting the metal parts, excess mortar must be emerged around the anchor element.</p>
		<p>For overhead installations support the metal part with wedges (e. g. centering wedges) or fischer overhead clips.</p>	 <p>For push through installation fill the annular gap with mortar</p>
10		<p>Wait for the specified curing time <math>t_{cure}</math> see <b>table B7.2</b></p>	<p>11</p>  <p>Mounting the fixture <math>\max T_{inst}</math> see <b>tables B3.1 and B4.1</b></p>
Option		<p>After the minimum curing time is reached, the gap between metal part and fixture (annular clearance) may be filled with mortar via the filling disc. Compressive strength <math>\geq 50 \text{ N/mm}^2</math> (e.g. injection mortars UPM 33, UPM 44, UPM 55). ATTENTION: Using filling disc reduces <math>t_{fix}</math> (usable length of the anchor)</p>	

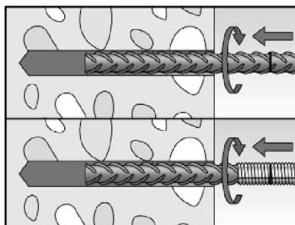
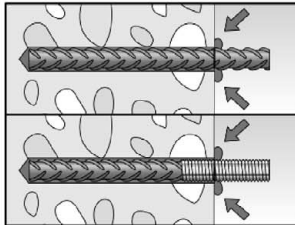
#### Installation reinforcing bars and Upat rebar anchor FRA

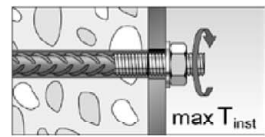
9		<p>Only use clean and oil-free reinforcing bars or Upat rebar anchor FRA. Mark the setting depth. Turn while using force to push the reinforcement bar or the Upat rebar anchor FRA into the filled hole up to the setting depth mark</p>	
9		<p>When the setting depth mark is reached, excess mortar must be emerged from the mouth of the drill hole.</p>	
10		<p>Wait for the specified curing time <math>t_{cure}</math> see <b>table B7.2</b></p>	<p>11</p>  <p>Mounting the fixture <math>\max T_{inst}</math> see <b>table B6.1</b></p>

injection system UPM 44

**Intended use**  
Installation instructions part 3

**Annex B 10**

Appendix 18 / 32

**Table C1.1: Characteristic values for steel failure under tension / shear load of Upat anchor rods and standard threaded rods**

Anchor rod / standard threaded rod			M6	M8	M10	M12	M16	M20	M24	M27	M30		
<b>Bearing capacity under tension load, steel failure <sup>3)</sup></b>													
Characteristic resistance $N_{Rk,s}$	Steel zinc plated	Property class	4.8	[kN]	8	15(13)	23(21)	33	63	98	141	184	224
			5.8		10	19(17)	29(27)	43	79	123	177	230	281
			8.8		16	29(27)	47(43)	68	126	196	282	368	449
	Stainless steel R and high corrosion resistant steel HCR		50		10	19	29	43	79	123	177	230	281
			70		14	26	41	59	110	172	247	322	393
			80		16	30	47	68	126	196	282	368	449
<b>Partial factors <sup>1)</sup></b>													
Partial factor $\gamma_{Ms,N}$	Steel zinc plated	Property class	4.8	[-]	1,50								
			5.8		1,50								
			8.8		1,50								
	Stainless steel R and high corrosion resistant steel HCR		50		2,86								
			70		1,50 <sup>2)</sup> / 1,87								
			80		1,60								
<b>Bearing capacity under shear load, steel failure <sup>3)</sup></b>													
<b>without lever arm</b>													
Characteristic resistance $V_{Rk,s}^0$	Steel zinc plated	Property class	4.8	[kN]	4	9(8)	14(13)	20	38	59	85	110	135
			5.8		6	11(10)	17(16)	25	47	74	106	138	168
			8.8		8	15(13)	23(21)	34	63	98	141	184	225
	Stainless steel R and high corrosion resistant steel HCR		50		5	9	15	21	39	61	89	115	141
			70		7	13	20	30	55	86	124	161	197
			80		8	15	23	34	63	98	141	184	225
Ductility factor	$k_7$	[-]	1,0										
<b>with lever arm</b>													
Charact. resistance $M_{Rk,s}^0$	Steel zinc plated	Property class	4.8	[Nm]	6	15(13)	30(27)	52	133	259	448	665	899
			5.8		7	19(16)	37(33)	65	166	324	560	833	1123
			8.8		12	30(26)	60(53)	105	266	519	896	1333	1797
	Stainless steel R and high corrosion resistant steel HCR		50		7	19	37	65	166	324	560	833	1123
			70		10	26	52	92	232	454	784	1167	1573
			80		12	30	60	105	266	519	896	1333	1797
<b>Partial factors <sup>1)</sup></b>													
Partial factor $\gamma_{Ms,V}$	Steel zinc plated	Property class	4.8	[-]	1.25								
			5.8		1.25								
			8.8		1.25								
	Stainless steel R and high corrosion resistant steel HCR		50		2.38								
			70		1.25 <sup>2)</sup> / 1.56								
			80		1.33								

<sup>1)</sup> In absence of other national regulations

<sup>2)</sup> Only admissible for high corrosion resist. steel HCR, with  $f_{yk} / f_{uk} \geq 0,8$  and  $A_s > 12\%$  (e.g. Upat anchor rods)

<sup>3)</sup> Values in brackets are valid for undersized threaded rods with smaller stress area  $A_s$  for hot dip galvanised standard threaded rods according to EN ISO 10684:2004+AC:2009

injection system UPM 44

**Performances**

Characteristic values for steel failure under tension / shear load of Upat anchor rods and standard threaded rods

**Annex C 1**

Appendix 19 / 32

**Table C2.1: Characteristic values for steel failure under tension / shear load of Upat internal threaded anchors IST**

Upat internal threaded anchors IST				M8	M10	M12	M16	M20	
<b>Bearing capacity under tension load, steel failure</b>									
Charact. resistance with screw	$N_{Rk,s}$	Property class	5.8	[kN]	19	29	43	79	123
			8.8		29	47	68	108	179
		Property class	R		26	41	59	110	172
		class 70	HCR		26	41	59	110	172
<b>Partial factors<sup>1)</sup></b>									
Partial factors	$\gamma_{Ms,N}$	Property class	5.8	[-]	1,50				
			8.8		1,50				
		Property class	R		1,87				
		class 70	HCR		1,87				
<b>Bearing capacity under shear load, steel failure</b>									
<b>Without lever arm</b>									
Charact. resistance with screw	$V^0_{Rk,s}$	Property class	5.8	[kN]	9,2	14,5	21,1	39,2	62,0
			8.8		14,6	23,2	33,7	54,0	90,0
		Property class	R		12,8	20,3	29,5	54,8	86,0
		class 70	HCR		12,8	20,3	29,5	54,8	86,0
Ductility factor			$k_7$	[-]	1,0				
<b>With lever arm</b>									
Charact. resistance with screw	$M^0_{Rk,s}$	Property class	5.8	[Nm]	20	39	68	173	337
			8.8		30	60	105	266	519
		Property class	R		26	52	92	232	454
		class 70	HCR		26	52	92	232	454
<b>Partial factors<sup>1)</sup></b>									
Partial factors	$\gamma_{Ms,V}$	Property class	5.8	[-]	1,25				
			8.8		1,25				
		Property class	R		1,56				
		class 70	HCR		1,56				

<sup>1)</sup> In absence of other national regulations

injection system UPM 44

**Performances**

Characteristic values for steel failure under tension / shear load of Upat internal threaded anchor IST

<b>Table C3.1: Characteristic values for steel failure under tension / shear load of reinforcing bars</b>										
Nominal diameter of the bar	$\phi$	8	10	12	14	16	20	25	28	
<b>Bearing capacity under tension load, steel failure</b>										
Characteristic resistance	$N_{Rk,s}$	[kN]	$A_s \cdot f_{uk}^{1)}$							
<b>Bearing capacity under shear load, steel failure</b>										
<b>Without lever arm</b>										
Characteristic resistance	$V^0_{Rk,s}$	[kN]	$0,5 \cdot A_s \cdot f_{uk}^{1)}$							
Ductility factor	$k_7$	[-]	1,0							
<b>With lever arm</b>										
Characteristic resistance	$M^0_{Rk,s}$	[Nm]	$1,2 \cdot W_{el} \cdot f_{uk}^{1)}$							
<sup>1)</sup> $f_{uk}$ or $f_{yk}$ respectively must be taken from the specifications of the reinforcing bar										

<b>Table C3.2: Characteristic values for steel failure under tension / shear load of Upat rebar anchors FRA</b>						
Upat rebar anchor FRA		M12	M16	M20	M24	
<b>Bearing capacity under tension load, steel failure</b>						
Characteristic resistance	$N_{Rk,s}$	[kN]	63	111	173	270
<b>Partial factor<sup>1)</sup></b>						
Partial factor	$\gamma_{Ms,N}$	[-]	1,4			
<b>Bearing capacity under shear load, steel failure</b>						
<b>Without lever arm</b>						
Characteristic resistance	$V^0_{Rk,s}$	[kN]	30	55	86	124
Ductility factor	$k_7$	[-]	1,0			
<b>With lever arm</b>						
Characteristic resistance	$M^0_{Rk,s}$	[Nm]	92	233	454	785
<b>Partial factor<sup>1)</sup></b>						
Partial factor	$\gamma_{Ms,V}$	[-]	1,56			

<sup>1)</sup> In absence of other national regulations

injection system UPM 44

**Performances**

Characteristic values for steel failure under tension / shear load of reinforcing bars and Upat rebar anchors FRA

**Annex C 3**

<b>Table C4.1: Characteristic values for concrete failure under tension / shear load</b>													
<b>Size</b>			<b>All sizes</b>										
<b>Tension load</b>													
Installation factor		$\gamma_{inst}$	[-]		See annex C 5 to C 8 and C 13 to C14								
<b>Factors for the compressive strength of concrete &gt; C20/25</b>													
Increasing factor for $\tau_{Rk}$	C25/30		$\Psi_c$	[-]	1,05								
	C30/37				1,10								
	C35/45				1,15								
	C40/50				1,19								
	C45/55				1,22								
	C50/60				1,26								
<b>Splitting failure</b>													
Edge distance	$h / h_{ef} \geq 2,0$		$C_{cr,sp}$	[mm]	1,0 $h_{ef}$								
	$2,0 > h / h_{ef} > 1,3$				4,6 $h_{ef} - 1,8 h$								
$h / h_{ef} \leq 1,3$		2,26 $h_{ef}$											
Spacing		$S_{cr,sp}$		2 $C_{cr,sp}$									
<b>Concrete cone failure</b>													
Uncracked concrete		$K_{ucr,N}$		[-]	11,0								
Cracked concrete		$K_{cr,N}$			7,7								
Edge distance		$C_{cr,N}$		[mm]	1,5 $h_{ef}$								
Spacing		$S_{cr,N}$			2 $C_{cr,N}$								
<b>Factors for sustained tension load</b>													
Temperature range			[-]		50 °C / 80 °C			72 °C / 120 °C					
Factor		$\Psi_{sus}^0$		[-]		0,74		0,87					
<b>Shear load</b>													
Installation factor		$\gamma_{inst}$		[-]		1,0							
<b>Concrete pry-out failure</b>													
Factor for pry-out failure		$k_8$		[-]		2,0							
<b>Concrete edge failure</b>													
Effective length of fastener in shear loading			$l_f$		[mm]		for $d_{nom} \leq 24$ mm: min ( $h_{ef}$ ; 12 $d_{nom}$ ) for $d_{nom} > 24$ mm: min ( $h_{ef}$ ; 8 $d_{nom}$ ; 300 mm)						
<b>Calculation diameters</b>													
Size					M6	M8	M10	M12	M16	M20	M24	M27	M30
Upat anchor rods and standard threaded rods		$d_{nom}$		[mm]	6	8	10	12	16	20	24	27	30
Upat internal threaded anchors IST		$d_{nom}$			-1)	12	16	18	22	28	-1)	-1)	-1)
Upat rebar anchor FRA		$d_{nom}$			-1)	-1)	-1)	12	16	20	25	-1)	-1)
Size (nominal diameter of the bar)			$\phi$		8	10	12	14	16	20	25	28	
Reinforcing bar		$d_{nom}$		[mm]		8	10	12	14	16	20	25	28
1) Anchortyp not part of the assessment													
injection system UPM 44										<b>Annex C 4</b> Appendix 22 / 32			
<b>Performances</b> Characteristic values for concrete failure under tension / shear load													



**Table C5.1: Characteristic values for combined pull-out and concrete failure for Upat anchor rods and standard threaded rods in hammer drilled holes; uncracked or cracked concrete**

Anchor rod / standard threaded rod		M6	M8	M10	M12	M16	M20	M24	M27	M30		
<b>Combined pullout and concrete cone failure</b>												
Calculation diameter	d	[mm]	6	8	10	12	16	20	24	27	30	
<b>Uncracked concrete</b>												
<b>Characteristic bond resistance in uncracked concrete C20/25</b>												
<u>Hammer-drilling with standard drill bit or hollow drill bit (dry or wet concrete)</u>												
Temperature range	I: 50 °C / 80 °C	$\tau_{Rk,ucr}$	[N/mm <sup>2</sup> ]	9,0	11,0	11,0	11,0	10,0	9,5	9,0	8,5	8,5
	II: 72 °C / 120 °C			6,5	9,5	9,5	9,0	8,5	8,0	7,5	7,0	7,0
<u>Hammer-drilling with standard drill bit or hollow drill bit (water filled hole)<sup>1)</sup></u>												
Temperature range	I: 50 °C / 80 °C	$\tau_{Rk,ucr}$	[N/mm <sup>2</sup> ]	-2)	-2)	-2)	9,5	8,5	8,0	7,5	7,0	7,0
	II: 72 °C / 120 °C			-2)	-2)	-2)	7,5	7,0	6,5	6,0	6,0	6,0
<b>Installation factors</b>												
Dry or wet concrete	$\gamma_{inst}$	[-]	1,0									
Water filled hole			-2)	-2)	-2)	1,2 <sup>1)</sup>						
<b>Cracked concrete</b>												
<b>Characteristic bond resistance in cracked concrete C20/25</b>												
<u>Hammer-drilling with standard drill bit or hollow drill bit (dry or wet concrete)</u>												
Temperature range	I: 50 °C / 80 °C	$\tau_{Rk,cr}$	[N/mm <sup>2</sup> ]	-2)	5,5	6,0	6,0	6,0	5,5	4,5	4,0	4,0
	II: 72 °C / 120 °C			-2)	4,5	5,0	6,0	6,0	5,0	4,0	3,5	3,5
<u>Hammer-drilling with standard drill bit or hollow drill bit (water filled hole)<sup>1)</sup></u>												
Temperature range	I: 50 °C / 80 °C	$\tau_{Rk,cr}$	[N/mm <sup>2</sup> ]	-2)	-2)	-2)	5,0	5,0	4,5	4,0	3,5	3,5
	II: 72 °C / 120 °C			-2)	-2)	-2)	4,0	4,0	4,0	3,5	3,0	3,0
<b>Installation factors</b>												
Dry or wet concrete	$\gamma_{inst}$	[-]	1,0									
Water filled hole			-2)	-2)	-2)	1,2 <sup>1)</sup>						

<sup>1)</sup> Only with coaxial cartridges: 380ml, 400 ml, 410 ml

<sup>2)</sup> No performance assessed

injection system UPM 44

**Performances**

Characteristic values for combined pull-out and concrete failure for Upat anchor rod and standard threaded rods

**Annex C 5**

Appendix 23 / 32

**Table C6.1: Characteristic values for combined pull-out and concrete failure for Upat internal threaded anchors IST in hammer drilled holes; uncracked concrete**

Upat Internal threaded anchor IST			M8	M10	M12	M16	M20	
<b>Combined pullout and concrete cone failure</b>								
Calculation diameter	d	[mm]	12	16	18	22	28	
<b>Uncracked concrete</b>								
<b>Characteristic bond resistance in uncracked concrete C20/25</b>								
Hammer-drilling with standard drill bit or hollow drill bit (dry or wet concrete)								
Temperature range	I: 50 °C / 80 °C	$\tau_{Rk,ucr}$	[N/mm <sup>2</sup> ]	10,5	10,0	9,5	9,0	8,5
	II: 72 °C / 120 °C			9,0	8,0	8,0	7,5	7,0
Hammer-drilling with standard drill bit or hollow drill bit (water filled hole) <sup>1)</sup>								
Temperature range	I: 50 °C / 80 °C	$\tau_{Rk,ucr}$	[N/mm <sup>2</sup> ]	10,0	9,0	9,0	8,5	8,0
	II: 72 °C / 120 °C			7,5	6,5	6,5	6,0	6,0
<b>Installation factors</b>								
Dry or wet concrete	$\gamma_{inst}$	[-]	1,0					
Water filled hole			1,2 <sup>1)</sup>					

<sup>1)</sup> Only with coaxial cartridges: 380 ml, 400 ml, 410 ml

injection system UPM 44

**Performances**

Characteristic values for combined pull-out and concrete failure for Upat internal threaded anchors IST

**Annex C 6**

Appendix 24 / 32

**Table C7.1: Characteristic values for combined pull-out and concrete failure for reinforcing bars in hammer drilled holes; uncracked or cracked concrete**

Nominal diameter of the bar		$\phi$	8	10	12	14	16	20	25	28		
<b>Combined pullout and concrete cone failure</b>												
Calculation diameter		d	[mm]	8	10	12	14	16	20	25	28	
<b>Uncracked concrete</b>												
<b>Characteristic bond resistance in uncracked concrete C20/25</b>												
Hammer-drilling with standard drill bit or hollow drill bit (dry or wet concrete)												
Tem- perature range	I: 50 °C / 80 °C		$\tau_{Rk,ucr}$	[N/mm <sup>2</sup> ]	11,0	11,0	11,0	10,0	10,0	9,5	9,0	8,5
	II: 72 °C / 120 °C				9,5	9,5	9,0	8,5	8,5	8,0	7,5	7,0
<b>Installation factor</b>												
Dry or wet concrete		$\gamma_{inst}$	[-]	1,0								
<b>Cracked concrete</b>												
<b>Characteristic bond resistance in cracked concrete C20/25</b>												
Hammer-drilling with standard drill bit or hollow drill bit (dry or wet concrete)												
Tem- perature range	I: 50 °C / 80 °C		$\tau_{Rk,cr}$	[N/mm <sup>2</sup> ]	- <sup>1)</sup>	3,0	5,0	5,0	5,0	4,5	4,0	4,0
	II: 72 °C / 120 °C				- <sup>1)</sup>	3,0	4,5	4,5	4,5	4,0	3,5	3,5
<b>Installation factor</b>												
Dry or wet concrete		$\gamma_{inst}$	[-]	1,0								

<sup>1)</sup> No performance assessed

injection system UPM 44

**Performances**

Characteristic values for combined pull-out and concrete failure for reinforcing bars

**Annex C 7**

**Table C8.1: Characteristic values for combined pull-out and concrete failure for Upat rebar anchors FRA in hammer drilled holes; uncracked or cracked concrete**

Upat rebar anchor FRA		M12	M16	M20	M24		
<b>Combined pullout and concrete cone failure</b>							
Calculation diameter	d	[mm]	12	16	20	25	
<b>Uncracked concrete</b>							
<b>Characteristic bond resistance in uncracked concrete C20/25</b>							
Hammer-drilling with standard drill bit or hollow drill bit (dry or wet concrete)							
Temperature range	I: 50 °C / 80 °C	$\tau_{Rk,ucr}$	[N/mm <sup>2</sup> ]	11,0	10,0	9,5	9,5
	II: 72 °C / 120 °C			9,0	8,5	8,0	7,5
<b>Installation factors</b>							
Dry or wet concrete	$\gamma_{inst}$	[-]	1,0				
<b>Cracked concrete</b>							
<b>Characteristic bond resistance in cracked concrete C20/25</b>							
Hammer-drilling with standard drill bit or hollow drill bit (dry or wet concrete)							
Temperature range	I: 50 °C / 80 °C	$\tau_{Rk,cr}$	[N/mm <sup>2</sup> ]	5,0	5,0	4,5	4,0
	II: 72 °C / 120 °C			4,5	4,5	4,0	3,5
<b>Installation factors</b>							
Dry or wet concrete	$\gamma_{inst}$	[-]	1,0				

injection system UPM 44

**Performances**  
 Characteristic values for combined pull-out and concrete failure for Upat rebar anchors FRA

**Table C9.1: Displacements for anchor rods**

Anchor rod		M6	M8	M10	M12	M16	M20	M24	M27	M30
<b>Displacement-Factors for tension load<sup>1)</sup></b>										
<b>Uncracked concrete; Temperature range I, II</b>										
$\delta_{N0}$ -Factor	[mm/(N/mm <sup>2</sup> )]	0,09	0,09	0,09	0,10	0,10	0,10	0,10	0,11	0,12
$\delta_{N\infty}$ -Factor		0,10	0,10	0,10	0,12	0,12	0,12	0,13	0,13	0,14
<b>Cracked concrete; Temperature range I, II</b>										
$\delta_{N0}$ -Factor	[mm/(N/mm <sup>2</sup> )]	- <sup>3)</sup>	0,12	0,12	0,12	0,13	0,13	0,13	0,14	0,15
$\delta_{N\infty}$ -Factor		- <sup>3)</sup>	0,25	0,27	0,30	0,30	0,30	0,35	0,35	0,40
<b>Displacement-Factors for shear load<sup>2)</sup></b>										
<b>Uncracked or cracked concrete; Temperature range I, II</b>										
$\delta_{V0}$ -Factor	[mm/kN]	0,11	0,11	0,11	0,10	0,10	0,09	0,09	0,08	0,07
$\delta_{V\infty}$ -Factor		0,12	0,12	0,12	0,11	0,11	0,10	0,10	0,09	0,09
<sup>1)</sup> Calculation of effective displacement: $\delta_{N0} = \delta_{N0\text{-Factor}} \cdot \tau_{Ed}$ $\delta_{N\infty} = \delta_{N\infty\text{-Factor}} \cdot \tau_{Ed}$ ( $\tau_{Ed}$ : Design value of the applied tensile stress)					<sup>2)</sup> Calculation of effective displacement: $\delta_{V0} = \delta_{V0\text{-Factor}} \cdot V_{Ed}$ $\delta_{V\infty} = \delta_{V\infty\text{-Factor}} \cdot V_{Ed}$ ( $V_{Ed}$ : Design value of the applied shear force)					
<sup>3)</sup> No performance assessed										

**Table C9.2: Displacements for Upat internal threaded anchors IST**

Upat Internal threaded anchor IST		M8	M10	M12	M16	M20
<b>Displacement-Factors for tension load<sup>1)</sup></b>						
<b>Uncracked concrete; Temperature range I, II</b>						
$\delta_{N0}$ -Factor	[mm/(N/mm <sup>2</sup> )]	0,10	0,11	0,12	0,13	0,14
$\delta_{N\infty}$ -Factor		0,13	0,14	0,15	0,16	0,18
<b>Displacement-Factors for shear load<sup>2)</sup></b>						
<b>Uncracked concrete; Temperature range I, II</b>						
$\delta_{V0}$ -Factor	[mm/kN]	0,12	0,12	0,12	0,12	0,12
$\delta_{V\infty}$ -Factor		0,14	0,14	0,14	0,14	0,14
<sup>1)</sup> Calculation of effective displacement: $\delta_{N0} = \delta_{N0\text{-Factor}} \cdot \tau_{Ed}$ $\delta_{N\infty} = \delta_{N\infty\text{-Factor}} \cdot \tau_{Ed}$ ( $\tau_{Ed}$ : Design value of the applied tensile stress)			<sup>2)</sup> Calculation of effective displacement: $\delta_{V0} = \delta_{V0\text{-Factor}} \cdot V_{Ed}$ $\delta_{V\infty} = \delta_{V\infty\text{-Factor}} \cdot V_{Ed}$ ( $V_{Ed}$ : Design value of the applied shear force)			

injection system UPM 44

**Performances**

Displacements for anchor rods and Upat internal threaded anchors IST

**Annex C 9**

**Table C10.1: Displacements for reinforcing bars**

Nominal diameter of the bar $\phi$		8	10	12	14	16	20	25	28
<b>Displacement-Factors for tension load<sup>1)</sup></b>									
<b>Uncracked concrete; Temperature range I, II</b>									
$\delta_{N0}$ -Factor	[mm/(N/mm <sup>2</sup> )]	0,09	0,09	0,10	0,10	0,10	0,10	0,10	0,11
$\delta_{N\infty}$ -Factor		0,10	0,10	0,12	0,12	0,12	0,12	0,12	0,13
<b>Cracked concrete; Temperature range I, II</b>									
$\delta_{N0}$ -Factor	[mm/(N/mm <sup>2</sup> )]	- <sup>3)</sup>	0,12	0,13	0,13	0,13	0,13	0,13	0,14
$\delta_{N\infty}$ -Factor		- <sup>3)</sup>	0,27	0,30	0,30	0,30	0,30	0,30	0,35
<b>Displacement-Factors for shear load<sup>2)</sup></b>									
<b>Uncracked or cracked concrete; Temperature range I, II</b>									
$\delta_{V0}$ -Factor	[mm/kN]	0,11	0,11	0,10	0,10	0,10	0,09	0,09	0,08
$\delta_{V\infty}$ -Factor		0,12	0,12	0,11	0,11	0,11	0,10	0,10	0,09
<sup>1)</sup> Calculation of effective displacement: $\delta_{N0} = \delta_{N0}\text{-Factor} \cdot \tau_{Ed}$ $\delta_{N\infty} = \delta_{N\infty}\text{-Factor} \cdot \tau_{Ed}$ ( $\tau_{Ed}$ : Design value of the applied tensile stress)					<sup>2)</sup> Calculation of effective displacement: $\delta_{V0} = \delta_{V0}\text{-Factor} \cdot V_{Ed}$ $\delta_{V\infty} = \delta_{V\infty}\text{-Factor} \cdot V_{Ed}$ ( $V_{Ed}$ : Design value of the applied shear force)				
<sup>3)</sup> No performance assessed									

**Table C10.2: Displacements for Upat rebar anchors FRA**

Upat rebar anchor FRA	M12	M16	M20	M24
<b>Displacement-Factors for tension load<sup>1)</sup></b>				
<b>Uncracked concrete; Temperature range I, II</b>				
$\delta_{N0}$ -Factor	0,10		0,10	
$\delta_{N\infty}$ -Factor	0,12		0,12	
<b>Cracked concrete; Temperature range I, II</b>				
$\delta_{N0}$ -Factor	0,12		0,13	
$\delta_{N\infty}$ -Factor	0,30		0,30	
<b>Displacement-Factors for shear load<sup>2)</sup></b>				
<b>Uncracked or cracked concrete; Temperature range I, II</b>				
$\delta_{V0}$ -Factor	0,10		0,09	
$\delta_{V\infty}$ -Factor	0,11		0,10	
<sup>1)</sup> Calculation of effective displacement: $\delta_{N0} = \delta_{N0}\text{-Factor} \cdot \tau_{Ed}$ $\delta_{N\infty} = \delta_{N\infty}\text{-Factor} \cdot \tau_{Ed}$ ( $\tau_{Ed}$ : Design value of the applied tensile stress)		<sup>2)</sup> Calculation of effective displacement: $\delta_{V0} = \delta_{V0}\text{-Factor} \cdot V_{Ed}$ $\delta_{V\infty} = \delta_{V\infty}\text{-Factor} \cdot V_{Ed}$ ( $V_{Ed}$ : Design value of the applied shear force)		

injection system UPM 44

**Performances**  
Displacements for reinforcing bars and Upat rebar anchors FRA

**Annex C 10**

Appendix 28 / 32

**Table C11.1: Characteristic values for steel failure under tension / shear load of Upat anchor rods and standard threaded rods under seismic action performance category C1 or C2**

Anchor rod / standard threaded rod		M10	M12	M16	M20	M24	M27	M30			
<b>Bearing capacity under tension load, steel failure<sup>1)</sup></b>											
<b>Upat anchor rods and standard threaded rods, performance category C1<sup>2)</sup></b>											
Characteristic resistance $N_{Rk,s,C1}$	Steel zinc plated	Property class	5.8	[kN]	29(27)	43	79	123	177	230	281
			8.8		47(43)	68	126	196	282	368	449
	Stainless steel R and high corrosion resistant steel HCR		50		29	43	79	123	177	230	281
			70		41	59	110	172	247	322	393
			80		47	68	126	196	282	368	449
<b>Upat anchor rods and standard threaded rods, performance category C2<sup>2)</sup></b>											
Characteristic resistance $N_{Rk,s,C2}$	Steel zinc plated	Property class	5.8	[kN]	- <sup>4)</sup>	39	72	108	- <sup>4)</sup>	- <sup>4)</sup>	- <sup>4)</sup>
			8.8		- <sup>4)</sup>	61	116	173	- <sup>4)</sup>	- <sup>4)</sup>	- <sup>4)</sup>
	Stainless steel R and high corrosion resistant steel HCR		50		- <sup>4)</sup>	39	72	108	- <sup>4)</sup>	- <sup>4)</sup>	- <sup>4)</sup>
			70		- <sup>4)</sup>	53	101	152	- <sup>4)</sup>	- <sup>4)</sup>	- <sup>4)</sup>
			80		- <sup>4)</sup>	61	116	173	- <sup>4)</sup>	- <sup>4)</sup>	- <sup>4)</sup>
<b>Bearing capacity under shear load, steel failure without lever arm<sup>1)</sup></b>											
<b>Upat anchor rods, performance category C1<sup>2)</sup></b>											
Characteristic resistance $V_{Rk,s,C1}^0$	Steel zinc plated	Property class	5.8	[kN]	17(16)	25	47	74	106	138	168
			8.8		23(21)	34	63	98	141	184	225
	Stainless steel R and high corrosion resistant steel HCR		50		15	21	39	61	89	115	141
			70		20	30	55	86	124	161	197
			80		23	34	63	98	141	184	225
<b>Standard threaded rods, performance category C1<sup>2)</sup></b>											
Characteristic resistance $V_{Rk,s,C1}^0$	Steel zinc plated	Property class	5.8	[kN]	12(11)	17	33	52	74	97	118
			8.8		16(14)	24	44	69	99	129	158
	Stainless steel R and high corrosion resistant steel HCR		50		11	15	27	43	62	81	99
			70		14	21	39	60	87	113	138
			80		16	24	44	69	99	129	158
<b>Upat anchor rods and standard threaded rods, performance category C2</b>											
Characteristic resistance $V_{Rk,s,C2}^0$	Steel zinc plated	Property class	5.8	[kN]	NPA <sup>4)</sup>	14	27	43	- <sup>4)</sup>	- <sup>4)</sup>	- <sup>4)</sup>
			8.8			22	44	69	- <sup>4)</sup>	- <sup>4)</sup>	- <sup>4)</sup>
	Stainless steel R and high corrosion resistant steel HCR		50			14	27	43	- <sup>4)</sup>	- <sup>4)</sup>	- <sup>4)</sup>
			70			20	39	60	- <sup>4)</sup>	- <sup>4)</sup>	- <sup>4)</sup>
			80			22	44	69	- <sup>4)</sup>	- <sup>4)</sup>	- <sup>4)</sup>
Factor for the annular gap	$\alpha_{gap}$	[-]	0,5 (1,0) <sup>3)</sup>								

<sup>1)</sup> Partial factors for performance category C1 or C2 see table C12.1; for Upat anchor rods ASTA/UPM-A the factor for steel ductility is 1,0

<sup>2)</sup> Values in brackets are valid for undersized threaded rods with smaller stress area  $A_s$  for hot dip galvanised standard threaded rods according to EN ISO 10684:2004+AC:2009.

<sup>3)</sup> Values in brackets are valid for filled annular gaps between the anchor rod and the through-hole in the attachment. It is necessary to use the filling disc according to Annex A 1

<sup>4)</sup> No performance assessed

injection system UPM 44

**Performances**

Characteristic values for steel failure under tension / shear load for Upat anchor rods and standard threaded rods under seismic action (performance category C1 / C2)

**Annex C 11**

Appendix 29 / 32

**Table C12.1: Partial factors for Upat anchor rods, standard threaded rods under seismic action performance category C1 or C2**

Anchor rod / standard threaded rod		M10	M12	M16	M20	M24	M27	M30
<b>Tension load, steel failure<sup>1)</sup></b>								
Partial factor $\gamma_{Ms,N}$	Steel zinc plated	Property class	5.8	[-]	1,50			
		8.8	1,50					
	Stainless steel R and high corrosion resistant steel HCR	50	2,86					
		70	1,50 <sup>2)</sup> / 1,87					
		80	1,60					
<b>Shear load, steel failure<sup>1)</sup></b>								
Partial factor $\gamma_{Ms,V}$	Steel zinc plated	Property class	5.8	[-]	1,25			
		8.8	1,25					
	Stainless steel R and high corrosion resistant steel HCR	50	2,38					
		70	1,25 <sup>2)</sup> / 1,56					
		80	1,33					

<sup>1)</sup> In absence of other national regulations

<sup>2)</sup> Only admissible for high corrosion resistant steel HCR, with  $f_{yk} / f_{uk} \geq 0,8$  and  $A_5 > 12 \%$  (e.g. Upat anchor rods)

injection system UPM 44

**Performances**

Partial factors under seismic action (performance category C1 and C2) for Upat anchor rods and standard threaded rods

**Annex C 12**

Appendix 30 / 32



**Table C13.1: Characteristic values** for combined pull-out and concrete failure for **Upat anchor rods** and **standard threaded rods** in hammer drilled holes under seismic action performance category **C1**

Anchor rod / standard threaded rod		M10	M12	M16	M20	M24	M27	M30	
<b>Characteristic bond resistance, combined pullout and concrete cone failure</b>									
<b>Hammer-drilling with standard drill bit or hollow drill bit (dry or wet concrete)</b>									
Temperature range	I: 50 °C / 80 °C	$\tau_{Rk,C1}$ [N/mm <sup>2</sup> ]	4,5	5,5	5,5	5,5	4,5	4,0	4,0
	II: 72 °C / 120 °C		4,0	4,5	4,5	4,5	4,0	3,5	3,5
<b>Hammer-drilling with standard drill bit or hollow drill bit (water filled hole <sup>1)</sup>)</b>									
Temperature range	I: 50 °C / 80 °C	$\tau_{Rk,C1}$ [N/mm <sup>2</sup> ]	-2)	5,0	5,0	4,5	4,0	3,5	3,5
	II: 72 °C / 120 °C		-2)	4,0	4,0	4,0	3,5	3,0	3,0
<b>Installation factors</b>									
Dry or wet concrete		$\gamma_{inst}$ [-]	1,0						
Water filled hole			-2)	1,2 <sup>1)</sup>					

<sup>1)</sup> Only with coaxial cartridges: 380ml, 400 ml, 410 ml

<sup>2)</sup> No performance assessed

injection system UPM 44

**Performances**

Characteristic values for combined pull-out and concrete failure under seismic action (performance category C1) for Upat anchor rods and standard threaded rods

**Annex C 13**

Appendix 31 / 32

**Table C14.1: Characteristic values** for combined pull-out and concrete failure for **Upat anchor rods** and **standard threaded rods** in hammer drilled holes under seismic action performance category **C2**

Anchor rod / standard threaded rod		M12	M16	M20	
<b>Characteristic bond resistance, combined pullout and concrete cone failure</b>					
<b>Hammer-drilling with standard drill bit or hollow drill bit (dry or wet concrete)</b>					
Temperature range	I: 50 °C / 80 °C	$\tau_{Rk,C2}$ [N/mm <sup>2</sup> ]	1,5	1,3	2,1
	II: 72 °C / 120 °C		1,3	1,2	1,9
<b>Hammer-drilling with standard drill bit or hollow drill bit (water filled hole <sup>3)</sup>)</b>					
Temperature range	I: 50 °C / 80 °C	$\tau_{Rk,C2}$ [N/mm <sup>2</sup> ]	1,3	1,1	1,8
	II: 72 °C / 120 °C		1,1	1,0	1,6
<b>Installation factors</b>					
Dry or wet concrete	$\gamma_{inst}$	[-]	1,0		
Water filled hole			-4)	1,2 <sup>3)</sup>	
<b>Displacement-Factors for tension load<sup>1)</sup></b>					
$\delta_{N,C2}$ (DLS)-Factor	[mm/(N/mm <sup>2</sup> )]	0,20	0,13	0,21	
$\delta_{N,C2}$ (ULS)-Factor		0,38	0,18	0,24	
<b>Displacement-Factors for shear load<sup>2)</sup></b>					
$\delta_{V,C2}$ (DLS)-Factor	[mm/kN]	0,18	0,10	0,07	
$\delta_{V,C2}$ (ULS)-Factor		0,25	0,14	0,11	

1) Calculation of effective displacement:

$$\delta_{N,C2} (DLS) = \delta_{N,C2} (DLS)\text{-Factor} \cdot \tau_{Ed}$$

$$\delta_{N,C2} (ULS) = \delta_{N,C2} (ULS)\text{-Factor} \cdot \tau_{Ed}$$

( $\tau_{Ed}$ : Design value of the applied tensile stress)

2) Calculation of effective displacement:

$$\delta_{V,C2} (DLS) = \delta_{V,C2} (DLS)\text{-Factor} \cdot V_{Ed}$$

$$\delta_{V,C2} (ULS) = \delta_{V,C2} (ULS)\text{-Factor} \cdot V_{Ed}$$

( $V_{Ed}$ : Design value of the applied shear force)

<sup>3)</sup> Only with coaxial cartridges: 380ml, 400 ml, 410 ml

<sup>4)</sup> No performance assessed

injection system UPM 44

**Performances**

Characteristic values for combined pull-out and concrete failure under seismic action (performance category C2) for Upat anchor rods and standard threaded rods

**Annex C 14**