



PRESTANDEDEKLARATION

DoP 0288

för Upat injektionssystem UPM 33 (Mortel för efterinstallerade armeringsjärnanslutningar)

SV

1. Produkttypens unika identifikationskod: **DoP 0288**
2. Avsedd användning/avsedda användningar: **System för efterinstallerad armeringsförbindelse med murbruk för användning i betong., Se bilaga, särskilt bilagor B1- B8.**
3. Tillverkare: **Upat Vertriebs GmbH, Bebelstraße 11, 79108 Freiburg im Breisgau, Tyskland**
4. Tillverkarens representant: **-**
5. System för bedömning och fortlöpande kontroll av prestanda: **1**
6. Europeiskt bedömningsdokument: **EAD 330087-00-0601**
Europeisk teknisk bedömning: **ETA-18/0973; 2019-03-22**
Tekniskt bedömningsorgan: **DIBt- Deutsches Institut für Bautechnik**
Anmält/anmälda organ: **2873 TU Darmstadt**
7. Angiven prestanda:
Mekanisk hållfasthet och stabilitet (BWR 1)
Karakteristisk bärförmåga för spänning (för statisk och kvasi-statisk belastning):
Bindkraft hos efterinstallerade armeringsjärn: Bilaga C1
Minskningfaktor: Bilaga C1
Förstärkningsfaktor för minsta förankringslängd: Bilaga C1

Säkerhet vid brand (BWR 2)
Reaktion vid brand: Klass (A1)

Motståndskraft mot eld:
Bindkraft vid ökad temperatur: NPd
8. Lämplig teknisk dokumentation och/eller särskild teknisk dokumentation: **-**

Prestandan för ovanstående produkt överensstämmer med den angivna prestandan. Denna prestandadeklaration har utfärdats i enlighet med förordning (EU) nr 305/2011 på eget ansvar av den tillverkare som anges ovan.

Undertecknad på tillverkarens vägnar av:

Dr.-Ing. Oliver Geibig, Verkställande direktör affärsenheter och teknik
Tumlingen, 2021-01-20

Jürgen Grün, Verkställande direktör kemi och kvalitet

Denna DoP har förberetts på olika språk. I händelse av tvist om tolkningen ska den engelska versionen alltid råda.

Bilagan innehåller frivilliga och kompletterande information på engelska som överskrider (det specifika språkets) lagkrav.

Specific Part

1 Technical description of the product

The subject of this European Technical Assessment is the post-installed connection, by anchoring or overlap connection joint, of reinforcing bars (rebars) in existing structures made of normal weight concrete, using the "Rebar connection with Upat UPM 33" in accordance with the regulations for reinforced concrete construction.

Reinforcing bars made of steel with a diameter ϕ from 10 to 25 mm according to Annex A and injection mortar UPM 33 or UPM 33 Relax are used for rebar connections. The rebar is placed into a drilled hole filled with injection mortar and is anchored via the bond between rebar, injection mortar and concrete.

The product description is given in Annex A.

2 Specification of the intended use in accordance with the applicable European assessment Document

The performances given in Section 3 are only valid if the anchor is used in compliance with the specifications and conditions given in Annex B.

The verifications and assessment methods on which this European Technical Assessment is based lead to the assumption of a working life of the rebar connection of at least 50 years. The indications given on the working life cannot be interpreted as a guarantee given by the producer, but are to be regarded only as a means for choosing the right products in relation to the expected economically reasonable working life of the works.

3 Performance of the product and references to the methods used for its assessment

3.1 Mechanical resistance and stability (BWR 1)

Essential characteristic	Performance
Characteristic resistance under static and quasi-static loading	See Annex C 1

3.2 Safety in case of fire (BWR 2)

Essential characteristic	Performance
Reaction to fire	Class A1
Resistance to fire	No performance assessed

4 Assessment and verification of constancy of performance (AVCP) system applied, with reference to its legal base

In accordance with European Assessment Document EAD No. 330087-00-0601, the applicable European legal act is: [96/582/EC].

The system(s) to be applied is (are): 1

Installed condition and examples of use

Figure A1.1:

Overlap joint with existing reinforcement for rebar connections of slabs and beams

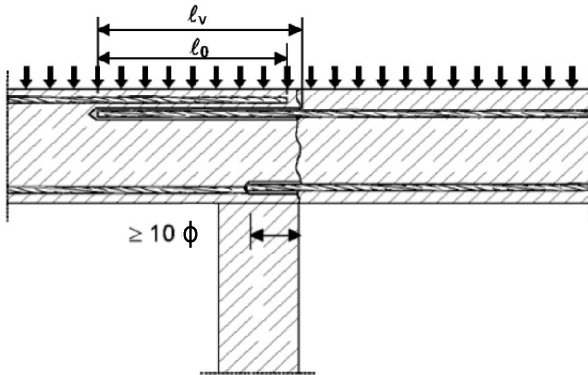

Figure A1.2:

Overlap joint with existing reinforcement at a foundation of a column or wall where the rebars are stressed

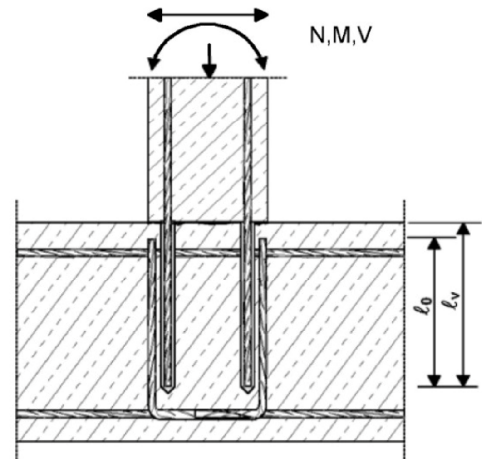

Figure A1.3:

End anchoring of slabs of beams (e.g. designed as simply supported)

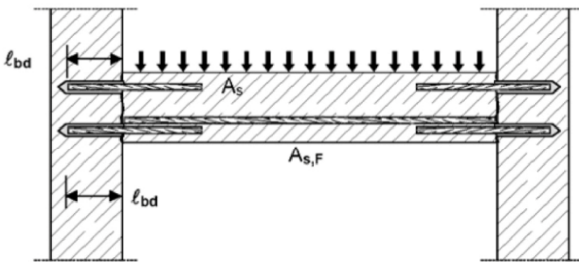

Figure A1.4:

Rebar connection for stressed primarily in compression

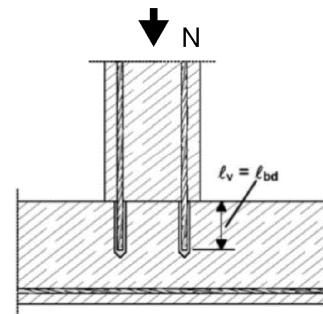
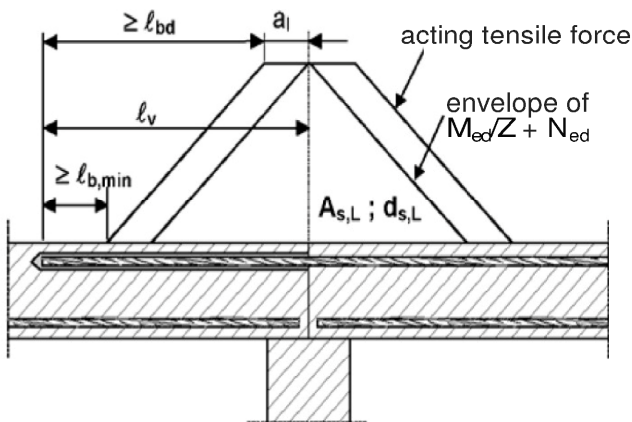

Figure A1.5:

Anchoring of reinforcement to cover the enveloped line of acting tensile force in the bending member



Note to **figure A1.1 to A1.5**

In the figures no traverse reinforcement is plotted, the traverse reinforcement shall comply with EN 1992-1-1: 2004+AC:2010.

Preparing of joints according to **Annex B 2**

Figures not to scale

Rebar connection with Upat UPM 33

Product description

Installed condition and examples of use for rebars

Annex A 1

Appendix 2 / 13

Overview system components

Injection cartridge (shuttle cartridge) UPM 33 with sealing cap

Size: 360 ml, 390 ml, 585 ml, 950 ml, 1500 ml

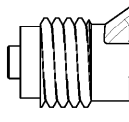
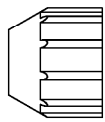

Marking: UPM 33 or UPM 33 Relax, processing notes, shelf-life, hazard code, curing times and processing times (depending on temperature), piston travel scale (optional), size, volume



Injection cartridge (coaxial cartridge) UPM 33 with sealing cap

Size: 300 ml, 380 ml, 400 ml, 410 ml

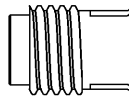
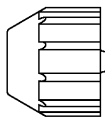

Marking: UPM 33 or UPM 33 Relax, processing notes, shelf-life, hazard code, curing times and processing times (depending on temperature), piston travel scale (optional), size, volume



Static mixer Upat MR Plus for injection cartridges from 300 ml to 410 ml

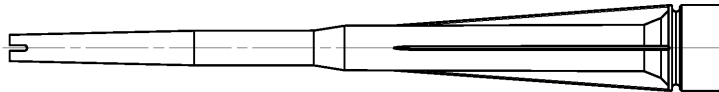

Static mixer Upat UMR for injection cartridges from 585 ml to 1500 ml

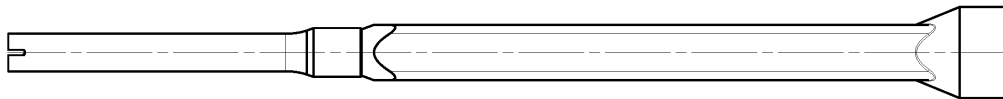

Injection adapter and extension tube Ø 9 for static mixer Upat MR Plus or extension tube Ø 15 for static mixer Upat UMR

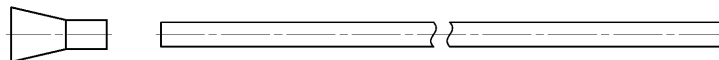

Reinforcing bar (rebar)

Size: $\phi 10$, $\phi 12$, $\phi 14$, $\phi 16$, $\phi 20$, $\phi 25$



marking setting depth

Blow-out pump ABP



Figures not to scale

Rebar connection with Upat UPM 33

Product description

Overview system components;
Injection mortar; reinforcing bar

Annex A 2

Appendix 3 / 13

Properties of reinforcing bars (rebar)

Figure A3.1:



- The minimum value of related rip area $f_{R,min}$ according to EN 1992-1-1:2004+AC:2010
- The maximum outer rebar diameter over the ribs shall be:
 - The nominal diameter of the rip $\phi + 2 * h$ ($h \leq 0,07 * \phi$)
 - (ϕ : Nominal diameter of the bar; h : rip height of the bar)

Table A3.1: Materials of rebars

Designation	Reinforcing bar (rebar)
Reinforcing bar EN 1992-1-1:2004+AC:2010, Annex C	Bars and de-coiled rods class B or C with f_{yk} and k according to NDP or NCL of EN 1992-1-1/NA $f_{uk} = f_{tk} = k \cdot f_{yk}$

Rebar connection with Upat UPM 33

Product description
Properties and materials of rebars

Annex A 3

Appendix 4 / 13

Specifications of intended use

Anchorage subject to:

- Static and quasi-static loads

Base materials:

- Reinforced or unreinforced normal weight concrete according to EN 206-1:2000
- Strength classes C20/25 to C35/45 according to EN 206-1:2000
- Maximum chloride concrete of 0,40% (CL 0.40) related to the cement content according to EN 206-1:2000
- Non-carbonated concrete

Note: In case of a carbonated surface of the existing concrete structure the carbonated layer shall be removed in the area of the post-installed rebar connection with a diameter of $\phi + 60$ mm prior to the installation of the new rebar.

The depth of concrete to be removed shall correspond to at least the minimum concrete cover in accordance with EN 1992-1-1 :2004+AC:2010. The foregoing may be neglected if building components are new and not carbonated and if building components are in dry conditions.

Temperature Range:

- -40°C to +80°C (max. short term temperature +80°C and max long term temperature +50°C)

Design:

- Anchorages are designed under the responsibility of an engineer experienced in anchorages and concrete work
- Verifiable calculation notes and drawings are prepared taking account of the forces to be transmitted.
- Design according to EN 1992-1-1 :2004+AC:2010 and Annex B 2.
- The actual position of the reinforcement in the existing structure shall be determined on the basis of the construction documentation and taken into account when designing.

Installation:

- Dry or wet concrete
- It must not be installed in flooded holes
- Hole drilling by hammerdrill or compressed air drill mode
- Overhead installation allowed
- The installation of post-installed rebar shall be done only by suitable trained installer and under Supervision on site; the conditions under which an installer may be considered as suitable trained and the conditions for Supervision on site are up to the Member States in which the installation is done
- Check the position of the existing rebars (if the position of existing rebars is not known, it shall be determined using a rebar detector suitable for this purpose as well as on the basis of the construction documentation and then marked on the building component for the overlap joint)

Rebar connection with Upat UPM 33

Intended use
Specifications

Annex B 1

Appendix 5 / 13

General construction rules for post-installed rebars

Figure B2.1:

- Only tension forces in the axis of the rebar may be transmitted
- The transfer of shear forces between new concrete and existing structure shall be designed additionally according to EN 1992-1-1:2004+AC:2010
- The joints for concreting must be roughened to at least such an extent that aggregate protrude

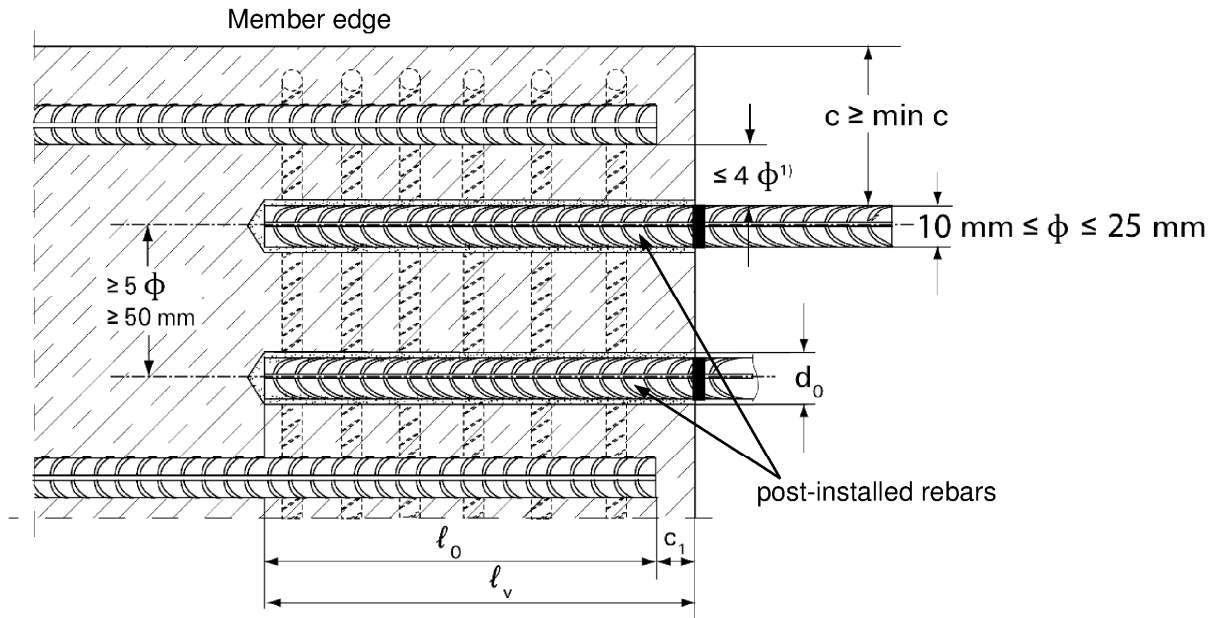

¹⁾ If the clear distance between lapped bars exceeds 4ϕ then the lap length shall be increased by the difference between the clear bar distance and 4ϕ

- c concrete cover of post-installed rebar
 c_1 concrete cover at end-face of existing rebar
 $\min c$ minimum concrete cover according to table B3.1 and to EN 1992-1-1:2004+AC:2010, Section 4.4.1.2
 ϕ nominal diameter of the bar
 ℓ_0 lap length, according to EN 1992-1-1:2004+AC:2010, Section 8.7.3
 ℓ_v effective embedment depth, $\geq \ell_0 + c_1$
 d_0 nominal drill bit diameter, see Annex B 4

Figures not to scale

Rebar connection with Upat UPM 33

Intended use
 General construction rules for post-installed rebars

Annex B 2

Appendix 6 / 13

Table B3.1: Minimum concrete cover $\min c$ ¹⁾ depending of the drilling method and the drilling tolerance

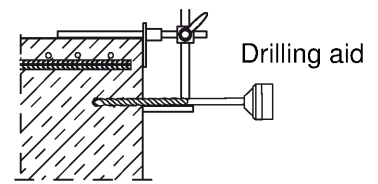

Drilling method	Nominal diameter of the bar ϕ [mm]	Minimum concrete cover $\min c$	
		Without drilling aid [mm]	With drilling aid [mm]
Hammer drilling	≤ 20	$30 \text{ mm} + 0,06 \ell_v$	$30 \text{ mm} + 0,02 \ell_v \geq 2 \phi$
	≥ 25	$40 \text{ mm} + 0,06 \ell_v$	$40 \text{ mm} + 0,02 \ell_v \geq 2 \phi$
Compressed air drilling	≤ 20	$50 \text{ mm} + 0,08 \ell_v$	$50 \text{ mm} + 0,02 \ell_v$
	≥ 25	$60 \text{ mm} + 0,08 \ell_v$	$60 \text{ mm} + 0,02 \ell_v$

1) See Annex B2, Figure B2.1

Note: The minimum concrete cover as specified in EN 1992-1-1:2004+AC:2010 must be observed

Table B3.2: Dispensers and cartridge sizes corresponding to maximum embedment depth $\ell_{v,max}$

Rebar	Manuel dispenser	Accu and pneumatic dispenser (small)	pneumatic dispenser (great)
	Cartridge size		
	< 500 ml		> 500 ml
ϕ [mm]	$\ell_{v,max} / \ell_{e,ges,max}$ [mm]		$\ell_{v,max} / \ell_{e,ges,max}$ [mm]
10	1000		1000
12			1200
14			1800
16			
20	700		1300
25			1000

Table B3.3: Working times t_{work} and curing times t_{cure}

Temperature in the anchorage base [°C]	Maximum working times ¹⁾ t_{work} [minutes]		Minimum curing times ²⁾ t_{cure} [minutes]	
	Upat UPM 33	Upat UPM 33 Relax	Upat UPM 33	Upat UPM 33 Relax
$>\pm 0$ to +5	13 ³⁾	---	180	360
$>+5$ to +10	9 ³⁾	20	90	180
$>+10$ to +20	5	10	60	120
$>+20$ to +30	4	6	45	60
$>+30$ to +40	2 ⁴⁾	4	35	30

¹⁾ Maximum time from the beginning of the injection to rebar setting and positioning

²⁾ For wet concrete the curing time must be doubled

³⁾ If the temperature in the concrete falls below 5°C the cartridge has to be warmed up to +15°C.

⁴⁾ If the temperature in the concrete exceeds 30 °C the cartridge has to be cooled down to +15°C up to 20°C

Rebar connection with Upat UPM 33

Intended use

Minimum concrete cover/ maximum embedment depth per dispenser and cartridge size / working times and curing times

Annex B 3

Appendix 7 / 13

Table B4.1: Installation tools for drilling and cleaning the bore hole and injection of the mortar

Rebar ϕ [mm]	Drilling and cleaning						Injection			
	Nominal drill bit diameter d_0 [mm]		Diameter of cutting edge d_{cut} [mm]		Steel brush diameter d_b [mm]		Cleaning nozzle [mm]	\emptyset of extension tube [mm]	Injection adapter [colour]	
10	12 ¹⁾	14 ¹⁾	$\leq 12,5$	$\leq 14,5$	12,5	15	11	9	white	blue
12	14 ¹⁾	16 ¹⁾	$\leq 14,5$	$\leq 16,5$	15	17	15		blue	red
14	18		$\leq 18,50$		19			19	9 or 15	yellow
16	20		$\leq 20,55$		25		green			
20	25		$\leq 25,55$		26,5		black			
25	30		$\leq 30,55$		32		28			grey

¹⁾ Both drill bit diameters can be used

Rebar connection with Upat UPM 33

Intended use

Installation tools for drilling and cleaning the bore hole and injection of the mortar

Annex B 4

Appendix 8 / 13

Safety regulations



Review the Material Safety Data Sheet (SDS) before use for proper and safe handling!

Wear well-fitting protective goggles and protective gloves when working with mortar Upat UPM 33

Important: Observe the instructions for use provided with each cartridge.

Installation instruction part 1; Installation with UPM 33

Drilling and cleaning the hole

Note: Before drilling, remove carbonized concrete; clean contact areas (see Annex B 1)

In case of aborted drill hole the drill hole shall be filled with mortar.

1		<p>Drill hole to the required embedment depth using a hammer-drill with carbide drill bit set in rotation hammer mode or a compressed air drill. Drill bit sizes see table B4.1.</p>
2		<p>Measure and control concrete cover c $C_{\text{drill}} = c + \phi / 2$ Drill parallel to surface edge and to existing rebar. Where applicable use drilling aid.</p> <p>For holes $l_v > 20$ cm use drilling aid. Three different options can be considered:</p> <ul style="list-style-type: none"> A) drilling aid B) Slat or spirit level C) Visual check
3	<p>min. 3x</p>	<p>Blowing three times from the back of the hole with oil-free compressed air (min. 6 bar) until return air stream is free of noticeable dust.</p>
4	<p>min. 3x</p>	<p>Brushing (with power drill) three times with the specified brush size (brush diameter $>$: borehole diameter) by inserting the round steel brush to the back of the hole in a twisting motion. The brush shall produce natural resistance as it enters the anchor hole. If this is not the case, please use a new brush or a brush with a larger diameter. For appropriate brushes see table B4.1</p>
5	<p>min. 3x</p>	<p>Blowing three times from the back of the hole with oil-free compressed air (min. 6 bar) until return air stream is free of noticeable dust.</p>

Rebar connection with Upat UPM 33

Intended use

Safety regulations; Installation instruction part 1

Annex B 5

Appendix 9 / 13

Installation instruction part 2; Installation with UPM 33

Rebar preparation and cartridge preparation

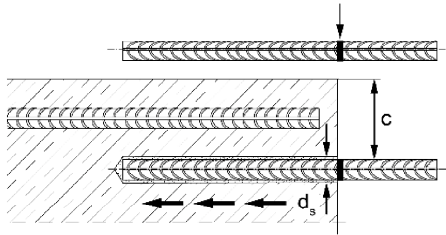
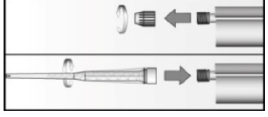
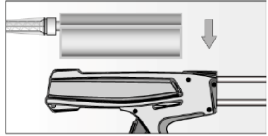
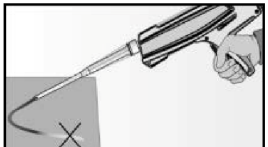
6		<p>Before use, make asure that the rebar is dry and free of oil or other residue. Mark the embedment depth ℓ_v on the rebar (e.g. with tape) Insert rebar in borehole, to verify hole and setting depth ℓ_v resp. $\ell_{e,ges}$</p>
7		<p>Twist off the sealing cap Twist on the static mixer (the spiral in the static mixer must be clearly visible).</p>
8		<p>Place the cartridge into a suitable dispenser.</p>
9		<p>Press out approximately 10 cm of mortar until the resin is permanently grey in colour. Mortar which is not grey in colour will not cure and must be disposed of.</p>

Rebar connection with Upat UPM 33

Intended use
Installation instruction part 2

Annex B 6

Appendix 10 / 13

Installation instruction part 3; Installation with UPM 33

Injection of the mortar; borehole depth ≤ 250 mm

10a

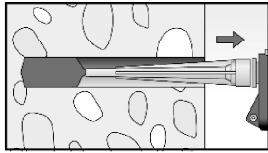

Inject the mortar from the back of the hole towards the front and slowly withdraw the mixing nozzle step by step after each trigger pull. Fill holes approximately 2/3 full, or as required to ensure that the annular gap between the rebar and the concrete is completely filled with adhesive over the embedment length.

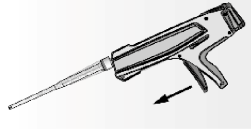

After injecting, depressurize the dispenser by pressing the release trigger. This will prevent further mortar discharge from the mixing nozzle.

Injection of the mortar; borehole depth > 250 mm

10b

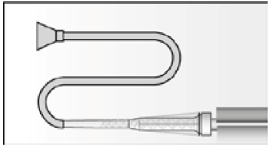

Assemble mixing nozzle, extension tube and injection adapter (see table B 4.1)

Mortar level mark

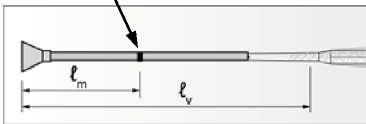

Mark the required mortar level l_m and embedment depth l_v resp. $l_{e,ges}$ with tape or marker on the injection extension tube.

a) Estimation:

$$l_m = \frac{1}{3} * l_v \text{ resp. } l_m = \frac{1}{3} * l_{e,ges}$$

b) Precise formula for optimum mortar volume:

$$l_m = l_v \text{ resp. } l_{e,ges} \left(\left(1,2 * \frac{d_s^2}{d_0^2} - 0,2 \right) \right) [\text{mm}]$$

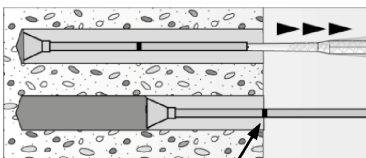

Mortar level mark

Insert injection adapter to back of the hole. Begin injection allowing the pressure of the injected adhesive mortar to push the injection adapter towards the front of the hole.

Fill holes approximately 2/3 full, or as required to ensure that the annular gap between the rebar and the concrete is completely filled with adhesive over the embedment length.

When using an injection adapter continue injection until the mortar level mark l_m becomes visible.

Maximum embedment depth see table B 3.2

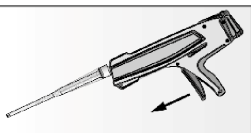

After injecting, depressurize the dispenser by pressing the release trigger. This will prevent further mortar discharge from the mixing nozzle.

Rebar connection with Upat UPM 33



Intended use
Installation instruction part 3

Annex B 7

Appendix 11 / 13

Installation instruction part 4; Installation with UPM 33

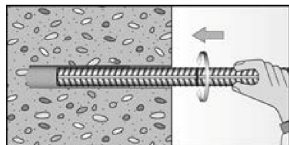
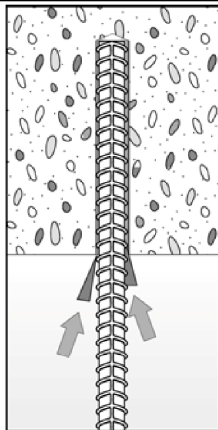
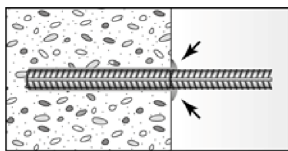
Insert rebar

11		For each installation insert the rebar slowly twisted into the borehole until the embedment mark is at the concrete surface level.
12		In case of overhead installation, support the rebar and secure it from falling till mortar started to harden, e.g. using wedges.
13		After installing the rebar the annular gap must be completely filled with mortar. Proper installation <ul style="list-style-type: none">• Desired anchoring embedment is reached l_v: embedment mark at concrete surface.• Excess mortar flows out of the borehole after the rebar has been fully inserted until the embedment mark.
14		Observe the working time " t_{work} " (see table B 3.3), which varies according to temperature of base material. Minor adjustments to the rebar position may be performed during the working time Full load may be applied only after the curing time " t_{cure} " has elapsed (see table B 3.3)

Rebar connection with Upat UPM 33

Intended use
Installation instruction part 4

Annex B 8

Appendix 12 / 13

Minimum anchorage length and minimum lap length

The minimum anchorage length $\ell_{b,min}$ and the minimum lap length $\ell_{o,min}$ according to EN 1992-1-1:2004+AC:2010 ($\ell_{b,min}$ acc. to Eq. 8.6 and Eq. 8.7 and $\ell_{o,min}$ acc. to Eq. 8.11) shall be multiply by a amplification factor α_{lb} according to table C1.1

Table C1.1: Amplification factor α_{lb} related to concrete strength class and drilling method

Concrete strength class	Drilling method	Amplification factor α_{lb}
C20/25 to C35/45	Hammer drilling and compressed air drilling	1,0

Table C1.2: Reduction factor k_b for hammer drilling and compressed air drilling

Hammer drilling and compressed air drilling				
Rebar ϕ [mm]	Reduction factor k_b			
	Concrete strenght class			
	C20/25	C25/30	C30/37	C35/45
10 to 25	1,00	1,00	1,00	1,00

Table C1.3: Design values of the bond resistance $f_{bd,PIR}$ in N/mm² for hammer drilling and compressed air drilling and for good bond conditions

$$f_{bd,PIR} = k_b \cdot f_{bd}$$

f_{bd} : Design value of the bond stress in N/mm² considering the concrete strength classes and the rebar diameter according to EN 1992-1-1: 2004+AC:2010
(for all other bond conditions multiply the values by 0,7)
 k_b : Reduction factor according to table C1.2

Rebar ϕ [mm]	Bond resistance $f_{bd,PIR}$ [N/mm ²]			
	Concrete strength class			
	C20/25	C25/30	C30/37	C35/45
10 to 25	2,3	2,7	3,0	3,4

Rebar connection with Upat UPM 33

Performances

Amplification factor α_{lb} , reduction factor k_b ,
Design values of the bond resistance $f_{bd,PIR}$

Annex C 1

Appendix 13 / 13