

PRESTANDEDEKLARATION

DoP 0305

för Upat Drop-in Anchor USA (Metallankare för användning i betong)

SV

1. Produkttypens unika identifikationskod: DoP 0305
2. Avsedd användning/avsedda användningar: Infästning i efterhand i osprucken betong, se bilaga, särskilt bilagor B1-B3.
3. Tillverkare: Upat Vertriebs GmbH, Bebelstraße 11, 79108 Freiburg im Breisgau, Tyskland
4. Tillverkarens representant: -
5. System för bedömning och fortlöpande kontroll av prestanda: 1
6. Europeiskt bedömningsdokument: EAD 330232-01-0601, Edition 05/2021
Europeisk teknisk bedömning: ETA-10/0172; 2022-05-11
Tekniskt bedömningsorgan: DIBt- Deutsches Institut für Bautechnik
Anmält/anmälda organ: 2873 TU Darmstadt

7. Angiven prestanda:

Mekanisk hållfasthet och stabilitet (BWR 1)

Karakteristisk bärförmåga för spänning (för statisk och kvasi-statisk belastning) Metod A:

Stålets motståndskraft: Bilagor C1

Motstånd mot att skruven dras ut: Bilagor C1

Motstånd i betongkonen: Bilagor C1

Kraftighet: Bilagor C1,C2

Minsta kant- och axelavstånd: Bilagor B2

Kantavstånd för att slippa sprickor under last: Bilagor C1

Karakteristisk bärförmåga för skjvning (för statisk och kvasi-statisk belastning), Metod A:

Motstånd i stålet (tvärlast): Bilagor C2

Motstånd mot fläkning: Bilagor C2

Karakteristisk motstånd för förenklad design:

Metod B: NPD

Metod C: NPD

Förskjutningar:

Förskjutningar under statisk och kvasistatisk belastning: Bilagor C3

Karakteristiskt motstånd och Förskjutningar för seismiska prestandakategorier C1 och C2:

Motstånd mot draglast, förskjutningar, kategori C1: NPD

Motstånd mot draglast, förskjutningar, kategori C2: NPD

Motstånd mot tvärlast, förskjutningar, kategori C1: NPD

Motstånd mot tvärlast, förskjutningar, kategori C2: NPD

Faktor cirkulärt hål: NPD

Säkerhet vid brand (BWR 2)

Reaktion vid brand: Klass (A1)

Motståndskraft mot eld:

Brandmotstånd i stålet (tvärlast): NPD

Brandmotstånd mot utdrag (draglast): NPD

Brandmotstånd i stålet (tvärlast): NPD

Hållbarhet:

Hållbarhet: Bilagor A3, B1

8. Lämplig teknisk dokumentation och/eller särskild teknisk dokumentation: -



Einfach. Sicher.



Prestandan för ovanstående produkt överensstämmer med den angivna prestandan. Denna prestandadeklaration har utfärdats i enlighet med förordning (EU) nr 305/2011 på eget ansvar av den tillverkare som anges ovan.

Undertecknad på tillverkarens vägnar av:

Dr.-Ing. Oliver Geibig, Verkställande direktör affärsenheter och teknik
Tumlingen, 2022-06-21

Jürgen Grün, Verkställande direktör kemi och kvalitet

Denna DoP har förberetts på olika språk. I händelse av tvist om tolkningen ska den engelska versionen alltid råda.

Bilagan innehåller frivilliga och kompletterande information på engelska som överskrider (det specifika språkets) lagkrav.

Specific Part

1 Technical description of the product

The Upat drop-in anchor USA is an anchor made of galvanized or stainless steel which is placed into a drilled hole and anchored by deformation-controlled expansion.

The fixture shall be anchored with a fastening screw or threaded rod.

The product description is given in Annex A.

2 Specification of the intended use in accordance with the applicable European Assessment Document

The performances given in Section 3 are only valid if the anchor is used in compliance with the specifications and conditions given in Annex B.

The verifications and assessment methods on which this European Technical Assessment is based lead to the assumption of a working life of the anchor of at least 50 years. The indications given on the working life cannot be interpreted as a guarantee given by the producer, but are to be regarded only as a means for choosing the right products in relation to the expected economically reasonable working life of the works.

3 Performance of the product and references to the methods used for its assessment

3.1 Mechanical resistance and stability (BWR 1)

Essential characteristic	Performance
Characteristic resistance to tension load (static and quasi static action) Method A	See Annex B2 and C1
Characteristic resistance to shear load (static and quasi static action)	See Annex C2
Displacements	See Annex C3
Characteristic resistance and displacements for seismic performance categories C1 and C2	No performance assessed

3.2 Safety in case of fire (BWR 2)

Essential characteristic	Performance
Reaction to fire	Class A1
Resistance to fire	No performance assessed

3.3 Aspects of durability linked with the Basic Works Requirements

Essential characteristic	Performance
Durability	See Annex B1

4 Assessment and verification of constancy of performance (AVCP) system applied, with reference to its legal base

In accordance with the European Assessment Document EAD 330232-01-0601 the applicable European legal act is: [96/582/EC].

The system to be applied is: 1

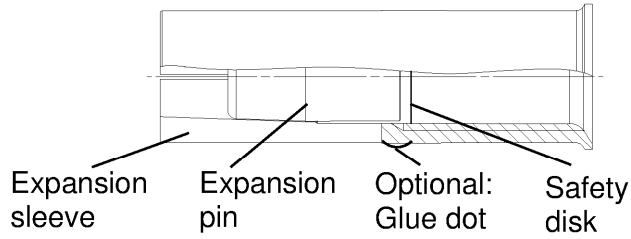
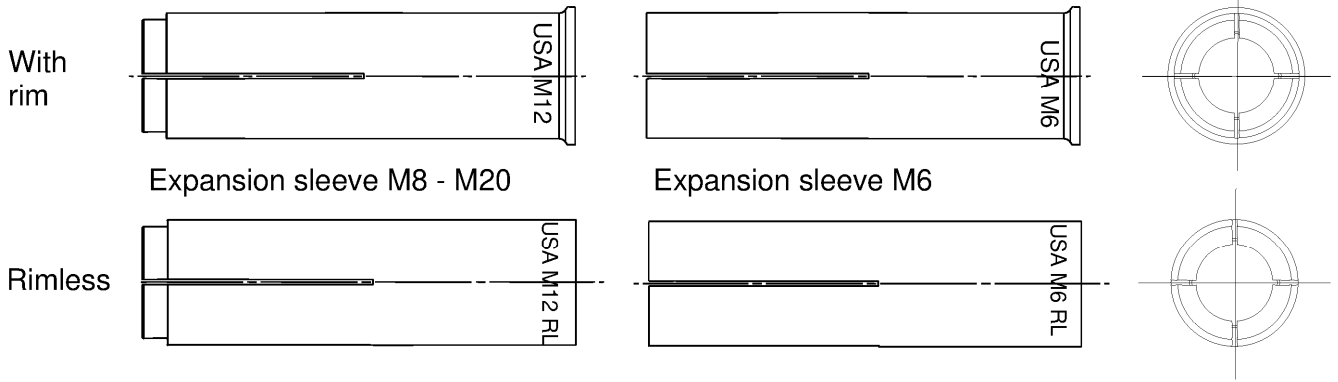

Intended use in concrete

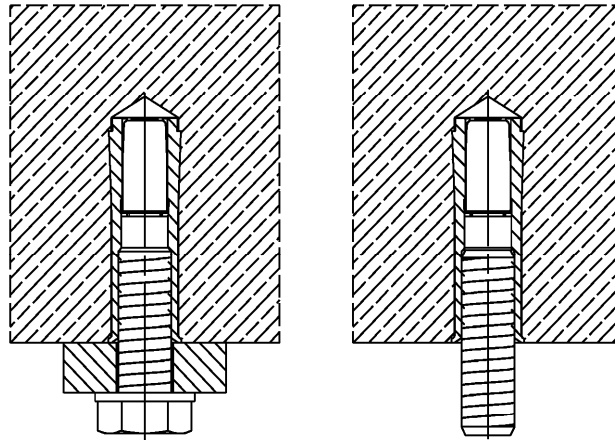

(Fig. not to scale)

Upat drop-in anchor USA

Product description
Anchor types
Installed condition

Annex A 1
Appendix 3 / 12

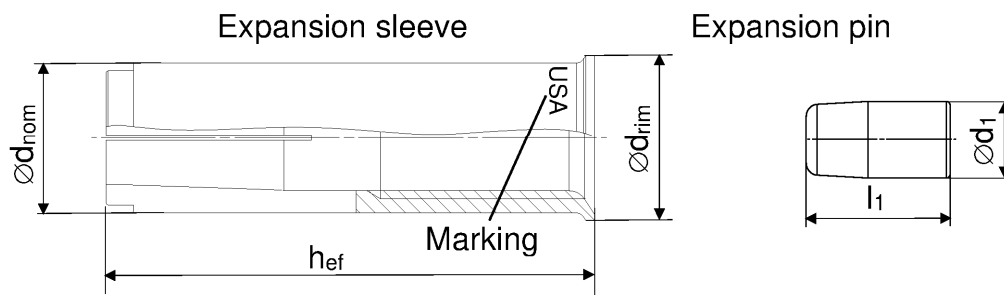

Table A2.1: Anchor size

Anchor size USA [mm]	M6x30	M8x30	M8x40	M10x30	M10x40	M12x50	M12x50 D	M16x65	M20x80
h_{ef}	30	30	40	30	40	50		65	80
$\varnothing d_{nom}$	8	10		12		15	16	20	25
$\varnothing d_{rim}$ (not applicable for USA RL)	9,5	11,5		13,5		16,5	17,5	21,5	27,0
$\varnothing d_1$	5	6,5		8		10		13,5	17,5
l_1	14	13,5		13	18	18		25	26

Distinctive feature

No groove for:

- USA M6x30..
- USA M8x30..
- USA M10x40..
- USA M12x50..
- USA M16x65..
- USA M20x80..

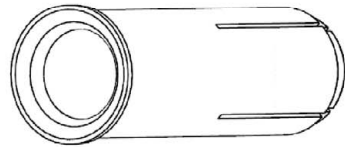

2 grooves for:

- USA M8x40..
- USA M10x30..

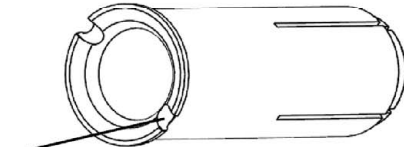

Table A2.2: Marking on anchor body

galvanised steel (gvz)		stainless steel (R)	
with rim	rimless	with rim	rimless
USA M6x30	USA M6x30 RL	USA M6x30 R	USA M6x30 RL R
USA M8x30	USA M8x30 RL	USA M8x30 R	USA M8x30 RL R
USA M8x40	USA M8x40 RL	USA M8x40 R	USA M8x40 RL R
USA M10x30	USA M10x30 RL	USA M10x30 R	USA M10x30 RL R
USA M10x40	USA M10x40 RL	USA M10x40 R	USA M10x40 RL R
USA M12x50	USA M12x50 RL	USA M12x50 R	USA M12x50 RL R
USA M12x50 D	USA M12x50 RL D	USA M12x50 D R	USA M12x50 RL D R
USA M16x65	USA M16x65 RL	USA M16x65 R	USA M16x65 RL R
USA M20x80	USA M20x80 RL	USA M20x80 R	USA M20x80 RL R

(Fig. not to scale)

Upat drop-in anchor USA

Product description
Anchor types

Annex A 2

Appendix 4 / 12

Expansion sleeve

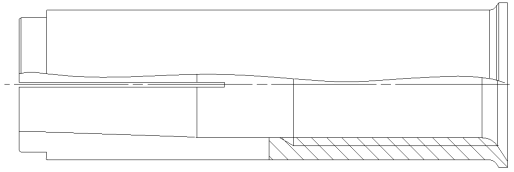

Expansion pin

**Table A3.1: Materials**

Designation	Material	
	galvanised steel ($\geq 5 \mu\text{m}$)	stainless steel (R)
Expansion sleeve	EN 10277:2018 or EN 10084:2008 or EN 10111:2008 or EN 10263:2018 or EN 10087:1999 or ASTM A29/A29M	EN 10088:2014
Expansion pin		
Fastening screw or threaded rod	steel, property class 4.6, 5.6, 5.8 or 8.8 according to EN ISO 898-1:2013	property class 50, 70 or 80 according to EN ISO 3506:2020

(Fig. not to scale)

Upat drop-in anchor USA

Product description
Material

Annex A 3

Appendix 5 / 12

Setting & drilling tools

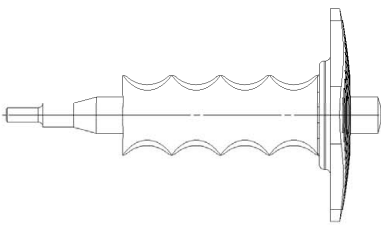
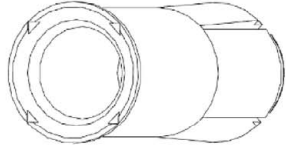
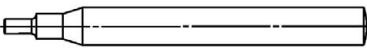
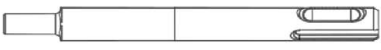
Setting tools	Marking	Description	Marking on USA with rim and rimless
	EHS Plus M..x hef	Manual setting tool with hand guard	
	EHS M..x hef	Manual setting tool basic format	
	EMS M..x hef	Machine setting tool with SDS Plus	No marking

Drilling tools

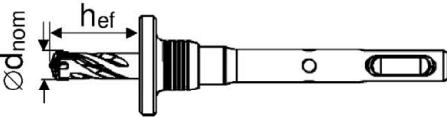
	EBB $\varnothing d_{nom} \times h_{ef}$	Stop drill
Or other usual driller		

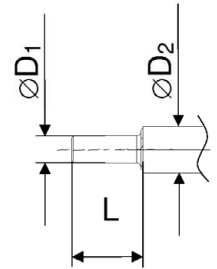

Table A4.1: Corresponding drill bits and parameters of setting tools

Manual setting tool	Machine setting tool	Stop drill	For anchor size USA	$\varnothing D1$ [mm]	$\varnothing D2$ [mm]	L [mm]
EHS (Plus) M6x25/30	EMS M6x25/30	EBB 8x30	USA M6x30	4,8	9,0	17,0
EHS (Plus) M8x25/30	EMS M8x25/30	EBB 10x30	USA M8x30	6,4	11,0	18,0
EHS (Plus) M8x40	EMS M8x40	EBB 10x40	USA M8x40			28,0
EHS (Plus) M10x25/30	EMS M10x25/30	EBB 12x30	USA M10x30	7,9	13,0	18,0
EHS (Plus) M10x40	EMS M10x40	EBB 12x40	USA M10x40			24,0
EHS (Plus) M12x50	EMS M12x50	EBB 15x50	USA M12x50	10,2	16,5	30,0
EHS (Plus) M12x50	EMS M12x50	EBB 16x50	USA M12x50 D			
EHS (Plus) M16x65	EMS M16x65	EBB 20x65	USA M16x65	13,5	22	36,0
EHS (Plus) M20x80	EMS M20x80	EBB 25x80	USA M20x80	16,4	27	50,0

(Fig. not to scale)

Upat drop-in anchor USA



Intended Use
Setting & Drilling tools

Annex A 4

Appendix 6 / 12

Specifications of intended use

Anchorage subject to:

Upat drop-in anchor USA (all versions)		M6	M8	M10	M12	M16	M20
Hammer drilling with standard drill bit		All types					
Hammer drilling with hollow drill bit with automatic cleaning							
Material	Steel	Zinc plated	✓				
	Stainless	R	✓				
Static and quasi-static loads		✓					
Uncracked concrete		✓					

Base materials:

- Reinforced or unreinforced normal concrete without fibres of strength classes C20/25 to C50/60 according to EN 206:2013+A1:2016

Use conditions (Environmental conditions):

- Structures subject to dry internal conditions: **USA, USA R**
- For all other conditions according to EN 1993-1-4:2006 + A1:2015 corresponding to corrosion resistance class CRC III **USA R**
Anchor types M6x30 R, M8x30 R and M10x30 R only for dry internal exposure

Design:

- Anchorage are to be designed under the responsibility of an engineer experienced in anchorages and concrete work
- Verifiable calculation notes and drawings are to be prepared taking account of the loads to be anchored. The position of the anchor is indicated on the design drawings (e.g. position of the anchor relative to reinforcement or to supports, etc.)
- Design of fastenings according to EN 1992-4:2018 and Technical Report TR 055, Edition February 2018
- Anchor sizes M6x30, M8x30 and M10x30 for statically indeterminate structural components only, when in case of failure, the load can be distributed to other fasteners.

Installation:

- Anchor installation carried out by appropriately qualified personnel and under the supervision of the person responsible for technical matters of the site
- Create drill hole with hammer drill or with hollow drill and vacuum cleaner
- The anchor may only be used once
- In case of aborted hole: New hole must be drilled at a minimum distance of twice the depth of the aborted hole or closer, if the hole is filled with a high strength mortar (e.g. UPM 66, UPM 55 or UPM 44) and only if the hole is not in the direction of the oblique tensile or shear load
- Anchor expansion by impact using the setting tools given in Annex A 4. The anchor is properly set if the stop of the setting tool reaches the expansion sleeve. The manual setting tool with installation control leaves a visible mark on the sleeve, as illustrated in Annex A 4 and B 3

Upat drop-in anchor USA

Intended Use
Specifications

Annex B 1

Appendix 7 / 12

Table B2.1: Installation parameters for concrete C20/25 to C50/60

Anchor size (all versions)			M6x30	M8x30	M8x40	M10x30	M10x40	M12x50	M12x50 D	M16x65	M20x80
			[mm]		[Nm]		[mm]		[mm]		[mm]
Nominal drill hole diameter	d_0	[mm]	8	10		12		15	16	20	25
Cutting diameter of drill bit	d_{cut}		8,45	10,45		12,50		15,50	16,50	20,55	25,55
Effective anchorage depth	h_{ef}		30	30	40	30	40	50		65	80
Maximum installation torque	$T_{inst,max}$	[Nm]	4	8		15		35	60	120	
Minimum drill hole depth	h_1	[mm]	32	33	43	33	43	54		70	85
Minimum screw-in depth	$l_{s,min}$		6	8		10		12	16	20	
Maximum screw-in depth	$l_{s,max}$		14	14		15	17	22	28	34	
Clearance of hole diameter	$\varnothing d_f \leq$		7	9		12		14	18	22	
$h_{min} = 80$ mm											
Minimum spacing	S_{min}	[mm]	70	110	200	200		-1)			
Minimum edge distance	C_{min}		150	150		150					
$h_{min} = 100$ mm											
Minimum spacing	S_{min}	[mm]	65	70	90	150	200		-1)		
Minimum edge distance	C_{min}		115	115		160	180				
$h_{min} = 120$ mm											
Minimum spacing	S_{min}	[mm]	65	70	85	95	145		-1)		
Minimum edge distance	C_{min}		115	115		140	150	200			
$h_{min} = 160$ mm											
Minimum spacing	S_{min}	[mm]	65	70	85	95	145		180	-1)	
Minimum edge distance	C_{min}		115	115		140	150	200	240		
$h_{min} = 200$ mm											
Minimum spacing	S_{min}	[mm]	65	70	85	95	145		180	190	
Minimum edge distance	C_{min}		115	115		140	150	200	240	280	

1) No performance assessed

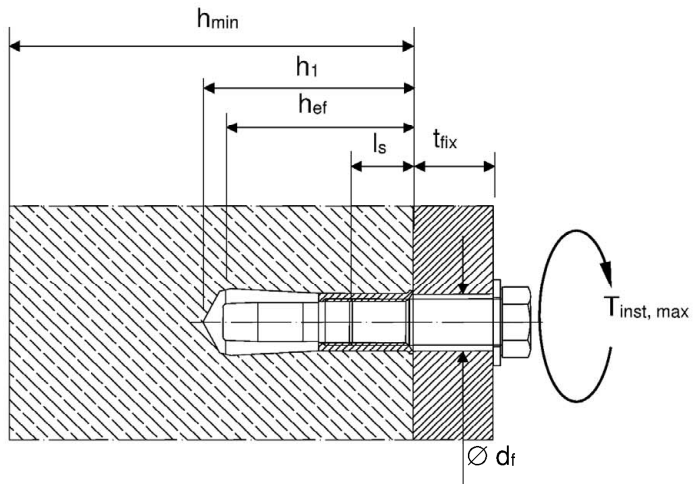
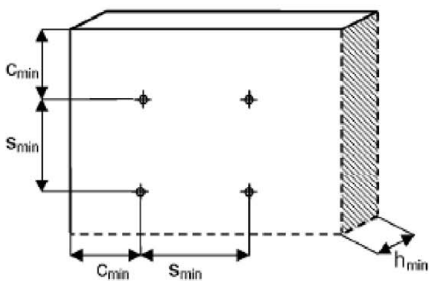

Fastening screw or threaded rod:

- Minimum property class and materials according to table A3.1
- The length of the fastening screw or threaded rod shall be determined depending on thickness of fixture t_{fix} , admissible tolerances and maximum screw-in depth $l_{s,max}$ as well as minimum screw-in depth $l_{s,min}$

(Fig. not to scale)

Upat drop-in anchor USA

Intended Use
Installation parameters

Annex B 2

Appendix 8 / 12

Installation instructions

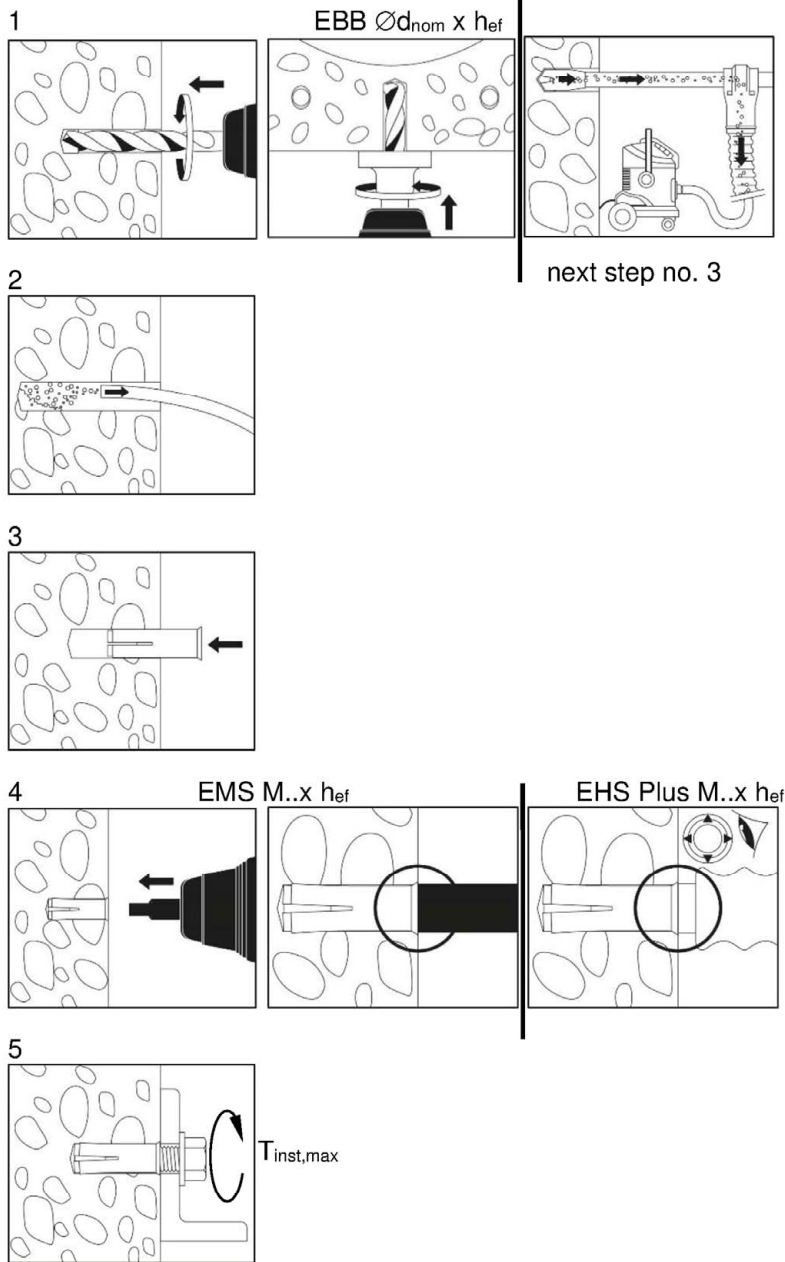

No.	Description
1	Create drill hole with hammer drill or stop drill or with hollow drill and vacuum cleaner
2	Clean from drill-dust
3	Set anchor till anchor is flush with surface of concrete
4	Expand the sleeve by driving the pin with the corresponding setting tool into the sleeve and control the correct setting
5	Fixation of fixture. Maximum installation torque $T_{inst,max}$ must not be exceeded

(Fig. not to scale)

Upat drop-in anchor USA

Intended Use
Installation instructions

Annex B 3
Appendix 9 / 12

Table C1.1: Characteristic values for tension loads under static and quasi-static action

USA	property class of the fastening screw or threaded rod		M6x30 ¹⁾	M8x30 ¹⁾	M8x40	M10x30 ¹⁾	M10x40	M12x50	M12x50 D	M16x65	M20x80
			Steel failure								
Installation factor	γ_{inst}	[-]	1,0								
Characteristic resistance	$N_{RK,s}$	[kN]	A4-50	10,1	18,3	29,0	42,1	78,3	122,4		
Partial factor	$\gamma_{Ms}^{4)}$	[-]	2,86								
Characteristic resistance	$N_{RK,s}$	[kN]	A4-70	14,1	19,6	24,9	45,1	59,0	73,8	117,2	
Partial factor	$\gamma_{Ms}^{4)}$	[-]	1,87	1,5				1,87	1,5		
Characteristic resistance	$N_{RK,s}$	[kN]	A4-80	16,1	19,6	24,9	45,1	59,0	73,8	117,2	
Partial factor	$\gamma_{Ms}^{4)}$	[-]	1,6	1,5							
Characteristic resistance	$N_{RK,s}$	[kN]	steel 4.6	8,0	14,6	23,2	33,7	62,7	97,9		
Partial factor	$\gamma_{Ms}^{4)}$	[-]	2,0								
Characteristic resistance	$N_{RK,s}$	[kN]	steel 5.6	10,1	18,3	29,0	42,1	78,3	122,4		
Partial factor	$\gamma_{Ms}^{4)}$	[-]	2,0								
Characteristic resistance	$N_{RK,s}$	[kN]	steel 5.8	10,1	17,2	21,8	39,6	42,1	64,7	102,8	
Partial factor	$\gamma_{Ms}^{4)}$	[-]	1,5								
Characteristic resistance	$N_{RK,s}$	[kN]	steel 8.8	13,5	17,2	21,8	39,6	53,3	64,7	102,8	
Partial factor	$\gamma_{Ms}^{4)}$	[-]	1,5								
Pullout failure											
Characteristic resistance C20/25	$N_{RK,p}$	[kN]		8,1	12,5	8,1	12,5	17,4	25,8	35,2	
Increasing Factors for $N_{RK,p}$ $N_{RK,p} = \psi_c \cdot N_{RK,p} (C20/25)$	ψ_c	C25/30	1,12								
		C30/37	1,22								
		C35/45	1,32								
		C40/50	1,41								
		C45/55	1,50								
		C50/60	1,58								
Installation factor	γ_{inst}	[-]	1,0								
Concrete cone and splitting failure											
Effective anchorage depth	h_{ef}	[mm]	30	40	30	40	50	65	80		
Factor for uncracked concrete	$k_{ucr,N}$	[-]	11,0 ²⁾								
Factor for cracked concrete	$k_{cr,N}$	[-]	No performance assessed								
Spacing	$s_{cr,N}$	[mm]	90	120	90	120	150	195	240		
Edge distance	$c_{cr,N}$	[mm]	45	60	45	60	75	97	120		
Spacing (splitting failure)	$s_{cr,sp}$	[mm]	210	280	210	320	350	455	560		
Edge distance (splitting failure)	$c_{cr,sp}$	[mm]	105	140	105	160	175	227	280		
Characteristic resistance to splitting	$N^0_{RK,sp}$	[kN]	$\min \{N^0_{RK,c}, N_{RK,p}\}^3)$								

¹⁾ Use restricted to anchoring of structural components which are statically indeterminate

²⁾ Based on concrete strength as cylinder strength

³⁾ $N^0_{RK,c}$ according to EN 1992-4:2018

⁴⁾ In absence of other national regulations

Upat drop-in anchor USA

Performances

Characteristic resistance to tension loads under static and quasi-static action

Annex C 1

Appendix 10 / 12

Table C2.1: Characteristic values for shear loads under static and quasi-static action

USA	property class of the fastening screw or threaded rod	M6x30 ¹⁾	M8x30 ¹⁾	M8x40	M10x30 ¹⁾	M10x40	M12x50	M12x50 D	M16x65	M20x80
		Factor for ductility	k_7 [-]	1,0						
Installation factor	γ_{inst} [-]	1,0								
Steel failure without lever arm										
Characteristic resistance	$V^0_{RK,s}$ [kN]	A4-50	5,0	9,2	14,5	21,1	39,2	61,2		
Partial factor	$\gamma_{Ms}^{(2)}$ [-]	2,38								
Characteristic resistance	$V^0_{RK,s}$ [kN]	A4-70	7,0	9,8	12,4	22,6	29,5	37	59	
Partial factor	$\gamma_{Ms}^{(2)}$ [-]	1,56			1,25			1,56	1,25	
Characteristic resistance	$V^0_{RK,s}$ [kN]	A4-80	8,0	9,8	12,4	22,6	30,4	36,9	58,6	
Partial factor	$\gamma_{Ms}^{(2)}$ [-]	1,33			1,25					
Characteristic resistance	$V^0_{RK,s}$ [kN]	steel 4.6	4,0	7,3	11,6	16,9	31	49		
Partial factor	$\gamma_{Ms}^{(2)}$ [-]	1,67								
Characteristic resistance	$V^0_{RK,s}$ [kN]	steel 5.6	5,0	9,2	14,5	21,1	39	61		
Partial factor	$\gamma_{Ms}^{(2)}$ [-]	1,67								
Characteristic resistance	$V^0_{RK,s}$ [kN]	steel 5.8	5,0	8,6	10,9	19,8	21,1	32	51	
Partial factor	$\gamma_{Ms}^{(2)}$ [-]	1,25								
Characteristic resistance	$V^0_{RK,s}$ [kN]	steel 8.8	6,8	8,6	10,9	19,8	27	32	51	
Partial factor	$\gamma_{Ms}^{(2)}$ [-]	1,25								
Steel failure with lever arm										
Characteristic resistance	$M^0_{RK,s}$ [Nm]	A4-50	8	19	37	66	166	324		
Partial factor	$\gamma_{Ms}^{(2)}$ [-]	2,38								
Characteristic resistance	$M^0_{RK,s}$ [Nm]	A4-70	11	26	52	92	232	454		
Partial factor	$\gamma_{Ms}^{(2)}$ [-]	1,56								
Characteristic resistance	$M^0_{RK,s}$ [Nm]	A4-80	12	30	60	105	266	519		
Partial factor	$\gamma_{Ms}^{(2)}$ [-]	1,33								
Characteristic resistance	$M^0_{RK,s}$ [Nm]	steel 4.6	6,1	15	30	52	133	259		
Partial factor	$\gamma_{Ms}^{(2)}$ [-]	1,67								
Characteristic resistance	$M^0_{RK,s}$ [Nm]	steel 5.6	7,6	19	37	66	166	324		
Partial factor	$\gamma_{Ms}^{(2)}$ [-]	1,67								
Characteristic resistance	$M^0_{RK,s}$ [Nm]	steel 5.8	7,6	19	37	66	166	324		
Partial factor	$\gamma_{Ms}^{(2)}$ [-]	1,25								
Characteristic resistance	$M^0_{RK,s}$ [Nm]	steel 8.8	12	30	60	105	266	517		
Partial factor	$\gamma_{Ms}^{(2)}$ [-]	1,25								
Concrete pryout failure										
Factor for pryout failure	k_8 [-]	1,74			1,9	1,74	1,9	2,0		
Concrete edge failure										
Effective length of anchor	l_f [mm]	30			40	30	40	50	65	80
Effective diameter of anchor	d_{nom} [mm]	8	10		12		15	16	20	25

¹⁾ Use restricted to anchoring of structural components which are statically indeterminate

²⁾ In absence of other national regulations

Upat drop-in anchor USA

Performances

Characteristic resistance to shear loads under static and quasi-static action

Annex C 2

Appendix 11 / 12

Table C3.1: Displacements under tension and shear loads for USA in galvanised steel

USA			M6x30	M8x30	M8x40	M10x30	M10x40	M12x50	M12x50 D	M16x65	M20x80
			Tension load in C20/25 to C50/60	N	[kN]	4,0	6,1	4,0	6,1	8,5	
Displacement	δ_{N_0}	[mm]	0,1								
	δ_{N_∞}	[mm]	0,2								
Shear load in C20/25 to C50/60	V	[kN]	3,9	4,9	6,2		11,3	15,2	18,5	29,4	
Displacement	δ_{V_0}	[mm]	0,95	1,00	1,05		1,10		1,40	1,80	
	δ_{V_∞}	[mm]	1,40	1,50	1,60		1,70		2,10	2,70	

Table C3.2: Displacements under tension and shear loads for USA in stainless steel

USA R			M6x30	M8x30	M8x40	M10x30	M10x40	M12x50	M12x50 D	M16x65	M20x80
			Tension load in C20/25 to C50/60	N	[kN]	4,0	6,1	4,0	6,1	8,5	
Displacement	δ_{N_0}	[mm]	0,1								
	δ_{N_∞}	[mm]	0,2								
Shear load in C20/25 to C50/60	V	[kN]	3,2	5,6	7,1		12,9	13,5	21,1	33,5	
Displacement	δ_{V_0}	[mm]	0,95	1,00	1,05		1,10		1,40	1,80	
	δ_{V_∞}	[mm]	1,40	1,50	1,60		1,70		2,10	2,70	

Upat drop-in anchor USA

Performances
Displacements**Annex C 3**

Appendix 12 / 12